

T-CAP

Multifunctional Tools

- Significantly reduces machining cycle time
- Reduces need for multiple tools
- One tool for:
 - Drilling
 - Boring
 - Turning
 - Facing



Ingersoll
TAEGU
line

Member IMC Group
Ingersoll
Cutting Tools

TaeguTurn

New

T-CAP

The T-CAP multifunctional system enables the use of a single tool to conduct facing, external turning, drilling and boring operations, thus significantly cutting production cycle times and reducing the need for multiple tools and inserts when working with small components.



Features of the T-CAP multifunctional system

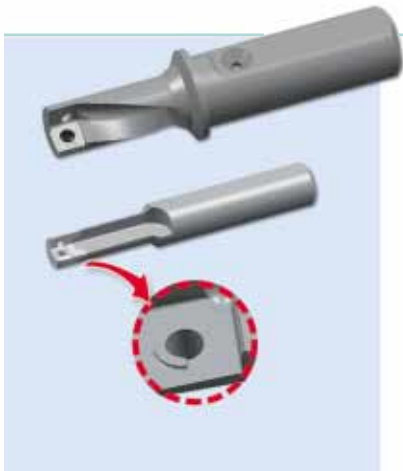

Tools

- With through coolant hole.
- Cylindrical shank with one flat surface.
- Insert seats on two surfaces for strong clamping.
- Helical flute for smooth chip flow and enough space for chip evacuation.
- Secure clamping feature.

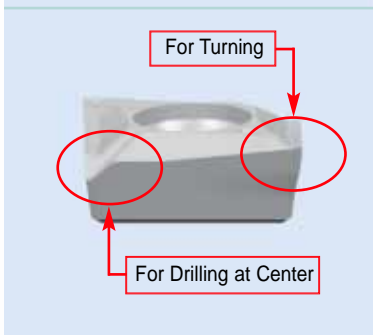

Inserts

- Two kinds of cutting edges for both drilling and turning.
- High helix cutting edge to minimize cutting forces.
- Excellent in controlling the chips at low feed and d.o.c.
- Optimum chip formation in drilling operation.

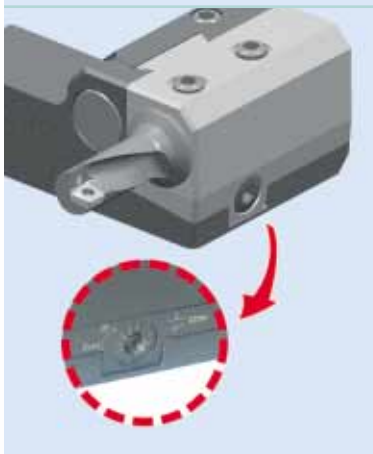

Clamping Units (Optional)

- Center height between tool and workpiece adjusting function in Lathes.
- Strong clamping by using dovetail slider.
- Micro adjustment scale : 0.01mm (.0004")
- Y axis adjustment range : +0.2 ~ -0.4mm (+.008" ~ -.016")

Contents

Tools and Inserts

Tools	4
Inserts	5
Clamping Units	6
Sleeves for Clamping Units	7
Kits	8

Technical Information

Chip control range	9
Set up	10
Radial adjustment (Off-center drilling)	11
Recommended cutting conditions	11



TOOLS AND INSERTS

Tools

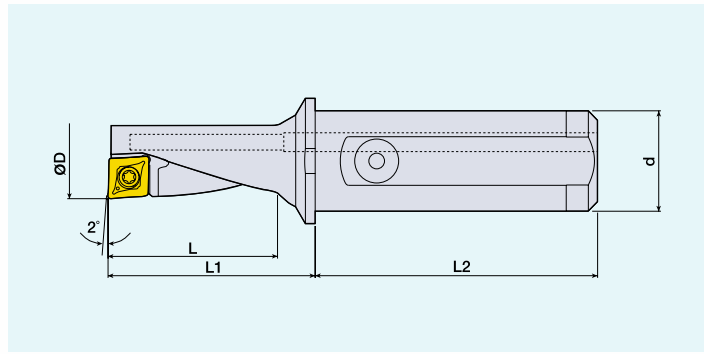

Metric Shanks

Designation	Stock		Dimension (inch)					Insert	Spare Parts	
	R	L	ØD	Ød	L	L1	L2		Screw	Wrench
TCAP 08R/L-2.25D	●	●	(8mm) .315	(10mm) .394	.708	.866	1.50	XCMT 0401	SO 18034I/HG	T 6
TCAP 10R/L-2.25D	●	●	(10mm) .394	(12mm) .472	.886	1.083	1.65	XCMT 0502	TS 20038I	T 6
TCAP 12R/L-2.25D	●	●	(12mm) .472	(16mm) .630	1.063	1.300	1.77	XCMT 0602	TS 22052I	T 7
TCAP 14R/L-2.25D	●	●	(14mm) .551	(16mm) .630	1.240	1.516	1.77	XCMT 0703	SM25-064-00	T 8
TCAP 16R/L-2.25D	●	●	(16mm) .630	(20mm) .787	1.417	1.732	1.97	XCMT 0803	SO 30100I	TD 9
TCAP 20R/L-2.25D	●	●	(20mm) .787	(25mm) .984	1.772	2.165	2.20	XCMT 10T3	SM35-088-60	DS-T10T

Inch Shanks

Designation	Stock		Dimension (inch)					Insert	Spare Parts	
	R	L	ØD	Ød	L	L1	L2		Screw	Wrench
TCAP 08R/L-2.25D-IN	●	●	(8mm) .315	.375	.708	.866	1.50	XCMT 0401	SO 18034I/HG	T 6
TCAP 10R/L-2.25D-IN	●	●	(10mm) .394	.500	.886	1.083	1.65	XCMT 0502	TS 20038I	T 6
TCAP 12R/L-2.25D-IN	●	●	(12mm) .472	.625	1.063	1.300	1.77	XCMT 0602	TS 22052I	T 7
TCAP 14R/L-2.25D-IN	●	●	(14mm) .551	.625	1.240	1.516	1.77	XCMT 0703	SM25-064-00	T8
TCAP 16R/L-2.25D-IN	●	●	(16mm) .630	.750	1.417	1.732	1.97	XCMY 0803	SO 30100I	TD9
TCAP 20R/L-2.25D-IN	●	●	(20mm) .787	1.00	1.772	2.165	2.20	XCMT 10T3	SM35-088-60	DS-T10T

- With through coolant
- Cylindrical shank with one flat clamping surface
- Two face contact for strong clamping
- Helical flute for smooth chip flow
- Large chip gullet for good chip evacuation
- Secure clamping feature

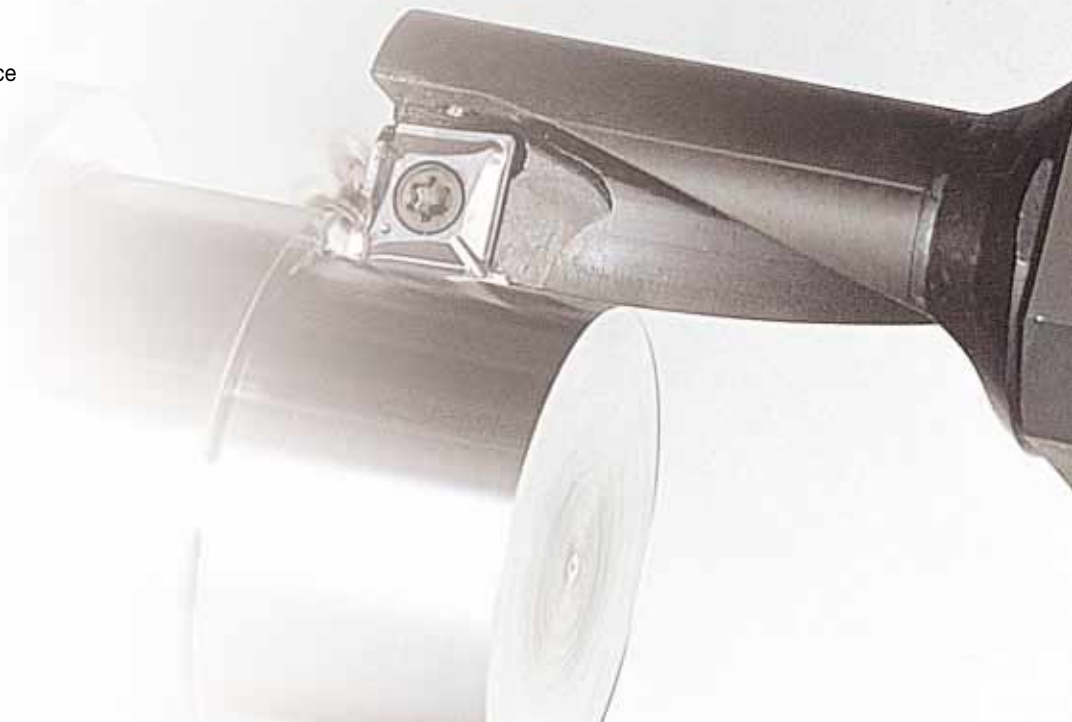

TOOLS AND INSERTS

Inserts

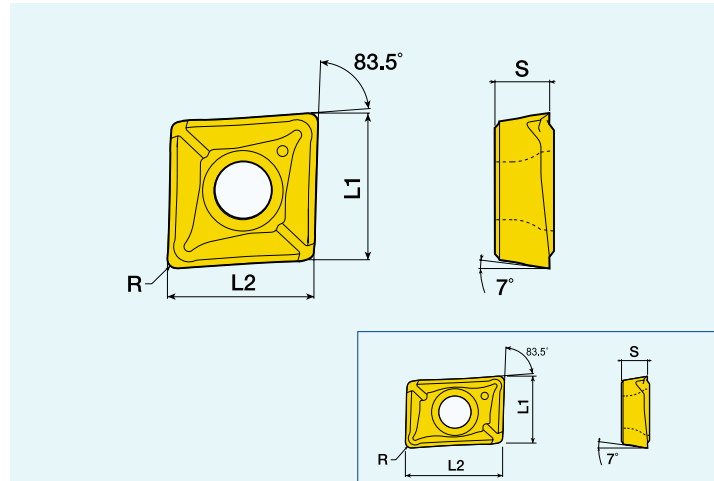

Designation	Stock		Dimension (inch)			
	TT 9030	TT 8020	L1	L2	S	R
XCMT 040104R TC	●	●	.173	.252	.067	.016
XCMT 040104L TC	●	●	.173	.252	.067	.016
XCMT 050204 TC	●	●	.220	.220	.083	.016
XCMT 060204 TC	●	●	.252	.252	.094	.016
XCMT 070304 TC	●	●	.295	.295	.125	.016
XCMT 080304 TC	●	●	.331	.331	.125	.016
XCMT 10T304 TC	●	●	.413	.413	.156	.016

- Two types of cutting edge for both drilling and turning
- High helix cutting edge to minimize cutting forces
- Excellent chip control at low feed and small d.o.c.
- Optimum chip formation in drilling operations
- Insert grades : TT9030 - general-purpose applications
TT8020 - Stainless Steel

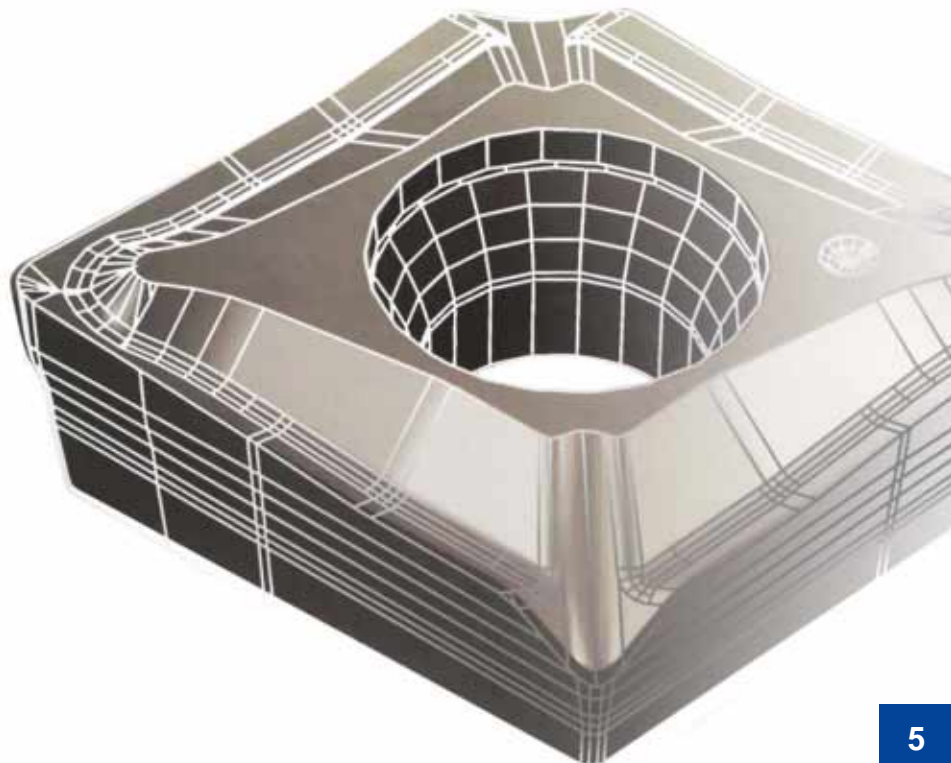

Clamping Units (Center Alignment System)

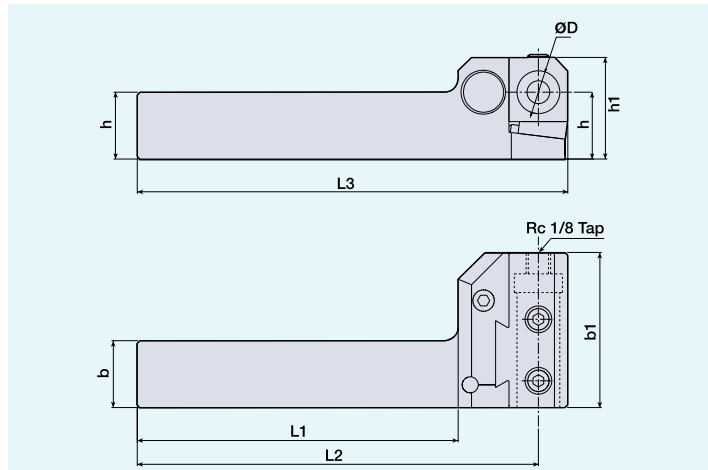

Inch

Designation	Stock	Dimension (inch)								Tool Holders
		h	b	ØD	h1	b1	L1	L2	L3	
TGHR 19.05-D15.88	●	.750	.750	.625	1.50	2.28	4.72	5.91	6.34	TCAP 08R/L-IN* TCAP 10R/L-IN* TCAP 12R/L-IN TCAP 14R/L-IN
TGHR 25.4-D15.88	●	1.00	1.00							
TGHR 25.4-D25.4	●	1.00	1.00	1.000	2.20	2.95	4.72	6.18	6.85	

*Requires sleeve

Inch

Designation	Spare Parts									
	Block	Wedge	Snap Ring	Wedge Screw	Mount'g Pin	Mount'g pin Scw	Mount'g Screw		Lock Screw	Wrench
TGHR 19.05-D15.88										
TGHR 25.4-D15.88	TGHR-D15 .88-BL	TGHR-WD	WSR 4	TGH-WS	TGH-MPI	TGH-MPS	SS M8 X1.25 X10-C	SS M8 X1.25 X 8	-	L-W4
TGHR 25.4-D25.4	TGHR-D25.4-BL	TGHR-WD -25	WSR 4	TGH-WS -25	TGH-MPI -25	TGH-MPS -25	SS M10X 1.5X12-C	SS M10X 1.5X10	SH M6X 1X20	L-W 4 L-W 5

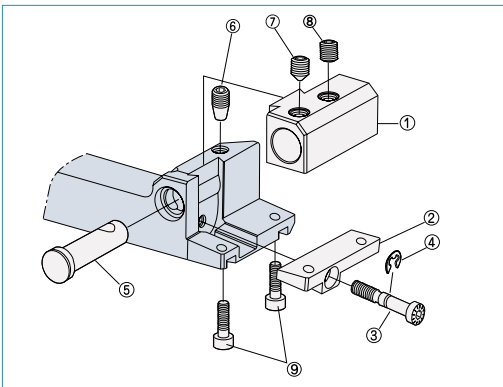

Number	1	2	3	4	5	6	7	8	9
Spare Parts	Block	Wedge	Wedge Screw	Snap Ring	Mount'g Pin	Mount'g Pin Scw.	Mount'g Screw		Lock Screw

- Center height adjustment of tool is possible on the lathe
- Dovetail slide design provides strong secure clamping and rigidity
- Micro adjustment scale : .0004"
- Y-Axis adjustment range : +.008" to -.016"

■ Sleeves for Clamping Units

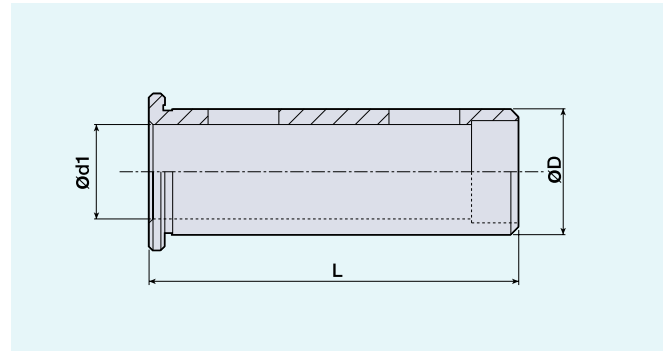

Metric to Metric

Designation	Stock	Dimension (mm)			Tools
		ØD	Ød1	L	
TSL 16-10	●	16	10	47	TCAP 08R/L
TSL 16-12	●	16	12	47	TCAP 10R/L
TSL 25-20	●	25	20	55	TCAP 16R/L

Inch to Metric

TSL19.05-10	●	3/4"	10 mm	2.00"	TCAP 08R/L
TSL19.05-12	●	3/4"	12 mm	2.00"	TCAP 10R/L
TSL25.4-10	●	1"	10 mm	2.75"	TCAP 08R/L
TSL25.4-12	●	1"	12 mm	2.75"	TCAP 10R/L
TSL25.4-16	●	1"	16 mm	2.75"	TCAP 12R/L or TCAP 14R/L
TSL25.4-20	●	1"	20 mm	2.75"	TCAP 16R/L
TSL31.75-10	●	1 1/4"	10 mm	3.25"	TCAP 08R/L
TSL31.75-12	●	1 1/4"	12 mm	3.25"	TCAP 10R/L
TSL31.75-16	●	1 1/4"	16 mm	3.25"	TCAP 12R/L or TCAP 14R/L
TSL31.75-20	●	1 1/4"	20 mm	3.25"	TCAP 16R/L
TSL31.75-25	●	1 1/4"	25 mm	3.25"	TCAP 20R/L
TSL38.1-10	●	1 1/2"	10 mm	3.375"	TCAP 08R/L
TSL38.1-12	●	1 1/2"	12 mm	3.375"	TCAP 10R/L
TSL38.1-16	●	1 1/2"	16 mm	3.375"	TCAP 12R/L or TCAP 14R/L
TSL38.1-20	●	1 1/2"	20 mm	3.375"	TCAP 16R/L
TSL38.1-25	●	1 1/2"	25 mm	3.375"	TCAP 20R/L

Inch to Inch

TSL 15.88-9.52	●	5/8"	3/8"	1.85"	TCAP 08R/L (-IN)
TSL 15.88-12.7	●	5/8"	1/2"	1.85"	TCAP 10R/L (-IN)
TSL 25.4-19.05	●	1"	3/4"	2.75"	TCAP 16R/L (-IN)

Multifunctional tools in a convenient kit

(Kits available for right hand tools only)



Each kit contains:

- T-CAP holder (1)
- XCMT inserts (10)
- Insert screws (5)
- Driver (1)



Metric

EDP #	Kit Item Number	Description
3104037	KITTCAP08R-2.25D TT9030	8 mm diameter, 10 mm shank
3104038	KITTCAP10R-2.25D TT9030	10 mm diameter, 12 mm shank
3104039	KITTCAP12R-2.25D TT9030	12 mm diameter, 16 mm shank
3104040	KITTCAP14R-2.25D TT9030	14 mm diameter, 16 mm shank
3104041	KITTCAP16R-2.25D TT9030	16 mm diameter, 20 mm shank
3104042	KITTCAP20R-2.25D TT9030	20 mm diameter, 25 mm shank

Inch

EDP #	Kit Item Number	Description
3104043	KITTCAP08R-2.25DIN TT9030	8 mm diameter, .375" shank
3104044	KITTCAP10R-2.25DIN TT9030	10 mm diameter, .500" shank
3104064	KITTCAP12R-2.25DIN TT9030	12 mm diameter, .625" shank
3104065	KITTCAP14R-2.25DIN TT9030	14 mm diameter, .625" shank
3104066	KITTCAP16R-2.25DIN TT9030	16 mm diameter, .750" shank
3104067	KITTCAP20R-2.25DIN TT9030	20 mm diameter, 1.00" shank



Chip control range

Drilling (Material:SAE 4140 (220BHN), V = 395 SFM)

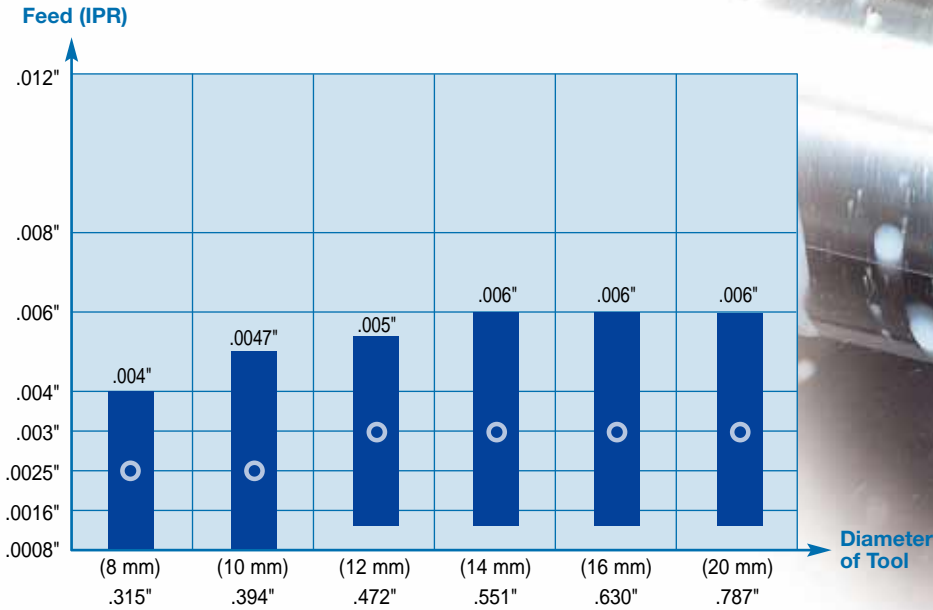

Turning (Material:SAE 1045 (220 BHN), V = 490 SFM)

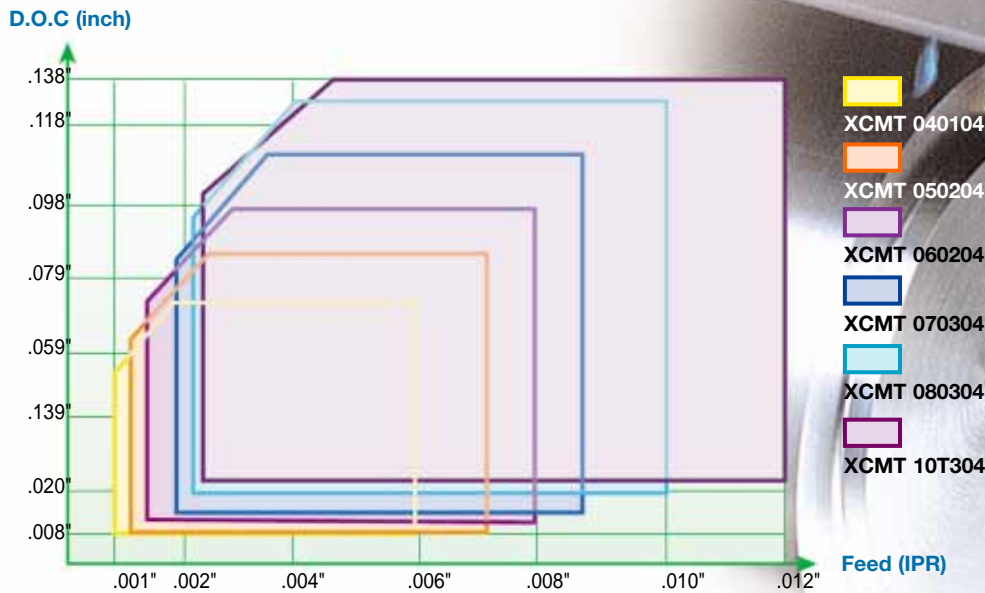

Set up

Insert positioning

- Cutting edge for drilling should be positioned in the center of tool body.

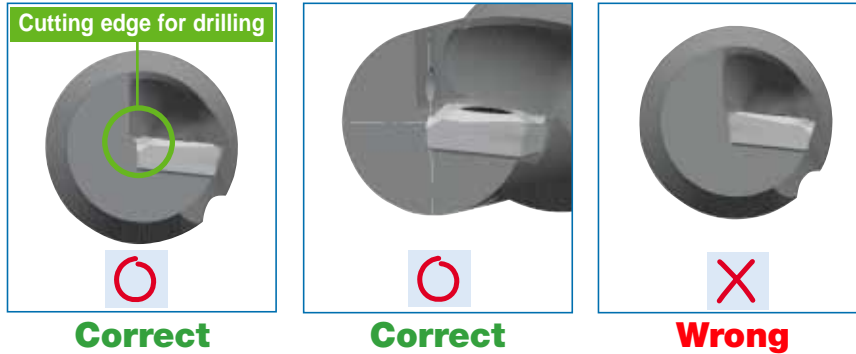

Core formation

Please check formation of core and its size after drilling to a depth of between .125" to .250". The diameter of the core should be within .006" to .018".

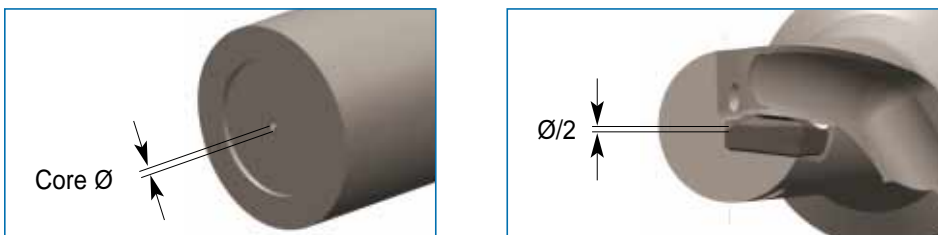

If you are using the clamping unit, adjustment is easy and accurately performed by adjusting the Y-Axis of the clamping unit.

If the T-CAP is being held in a fixed turret location, reverse the tool by 180 degrees and test again to see if core size is within acceptable tolerances.

- **If a core does not appear:**
It can cause breakage of insert and vibration when drilling or turning
- **If the size of the core is over the recommendations:**
It will cause overload and vibration problems during machining

Coolant pressure

- Coolant pressure must be above 30 psi in 2.25xD drills, regardless of drilling diameter. (Optimal pressure is above 70 psi)

Optimization of chip shape

- **Material with low carbon content (low carbon steel / low carbon alloy steel):**
High speed machining is recommended to make the chips thinner. Most problems are caused by thick chips.
- **Material with medium to high carbon content (carbon steel / alloy steel):**
Too tight (thick chip)? Increase speed if the speed is slow, or reduce feed.
Too loose (long chip)? Reduce speed if the speed is high, or increase feed.

Radial adjustment (Off-center drilling)

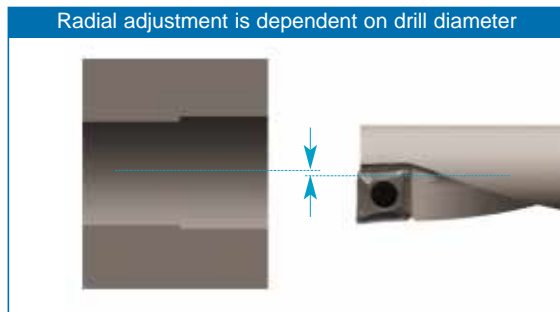

(inch)

Tool	Drill Dia.	Dmin	Dmax
TCAP 08 -	.315" (8mm)	.309"	.329"
TCAP 10 -	.394" (10mm)	.387"	.457"
TCAP 12 -	.472" (12mm)	.465"	.496"
TCAP 14 -	.551" (14mm)	.543"	.575"
TCAP 16 -	.630" (16mm)	.620"	.650"
TCAP 20 -	.787" (20mm)	.780"	.811"

Recommended cutting conditions

Cutting speed (Vc)

Workpiece Materials	Hardness(BHN)	Cutting speed : Vc (SFM)	
		In Drilling	In Turning & Boring
Low carbon steel(~0.25% C)	~ 150	425~790	490~895
Carbon steel(0.25%< C)	150~250	295~525	330~590
Low alloy steel	~180	395~690	460~755
Medium alloy steel	200~250	230~460	260~525
High alloy steel	250~350	165~330	200~395
Martensitic stainless steel	200	360~590	425~655
Austenitic stainless steel	200	295~525	330~590
Gray cast iron	180~220	360~590	395~655
Ductile cast iron	200~240	295~525	330~590
Aluminium alloy	60~130	330~1640	490~1970
Copper alloy	90~100	330~1310	330~1640

Cutting Conditions

Designation	Application	Cutting Conditions	
		DOC a_p (inches)	f (IPR)
XCMT 040104	External Turning	.023" (.008 ~ .070)	.002" (.001" ~ .006")
	Drilling	-	.002" (.001" ~ .004")
XCMT 050204	External Turning	.031" (.008 ~ .087)	.003" (.001" ~ .007")
	Drilling	-	.002" (.001" ~ .005")
XCMT 060204	External Turning	.039" (.012 ~ .098)	.003" (.001" ~ .008")
	Drilling	-	.003" (.001" ~ .005")
XCMT 070304	External Turning	.047" (.016 ~ .110)	.005" (.001" ~ .009")
	Drilling	-	.003" (.001" ~ .006")
XCMT 080304	External Turning	.059" (.016 ~ .126)	.005" (.001" ~ .010")
	Drilling	-	.003" (.001" ~ .006")
XCMT 10T304	External Turning	.071" (.020 ~ .138)	.005" (.001" ~ .012")
	Drilling	-	.003" (.001" ~ .006")

Ingersoll Cutting Tools for the Americas

Marketing & Technology Center
845 S. Lyford Road
Rockford, IL 61108-2749 U.S.A.
Tel: 815.387.6600
Fax: 815.387.6968
Email: info@ingersoll-imc.com
Internet: www.ingersoll-imc.com

Ingersoll Cutting Tool Ltd.
4510 Rhodes Drive, Unit #100
Windsor, Ontario N8W 5K5, Canada
Tel: 519.974.1019
Fax: 519.974.2260

Ingersoll Cutting Tools de México S.A. de C.V.
Carr. Saltillo Monterrey Km. 5.5, Local 2 y 3
Saltillo, Coahuila C.P. 25200, México
Tel: (844) 432.2546, (844) 432.2547
Fax: (844) 432.2544

Ingersoll Cutting Tools for Europe

Marketing & Technology Center
Ingersoll Werkzeuge GmbH
Kalteiche-Ring 21-25
35708 Haiger, Germany
Tel: 02773.742 0
Fax: 02773.742 812/814
Email: info@ingersoll-imc.de
Internet: www.ingersoll-imc.de

Member IMC Group
Ingersoll
Cutting Tools