

PRODUCT NEWS



Member IMC Group [®]

IT.TE.DI.



PRODUCT & STOCKING EXPANSION

The Tedimill is one of the fastest growing product lines within the Ingersoll line up of premium cutting tools. It is, with this in mind, that Ingersoll is pleased to announce additions to the standard product line, as well as expanded stock standard status of many catalog items.

*Now in stock are CAT 40, CAT 50, HSK 63, HSK 100 and BT 40 Tedimill adapters, including long versions. These items are highlighted in **RED** below.*

In addition, we've expanded the standard product line to include a 7" diameter, 20 pitch PCD Tedimill and several BT 30 Tedimill adapters.

Please refer to the following information, in addition to your Tedimill catalogs for all of your PCD/CBN face milling needs.

TEDIMILL VS. THE COMPETITION

The below test results are just two of many examples of the kind of productivity increases Ingersoll customers are realizing when utilizing Tedimill PCD cutters compared to our competition. As shown, Tedimill PCD facemilling cutters can be used for roughing as well as finish milling.

<i>Finish Milling Aluminum Crank Case</i>		
	PCD Tedimill 6"	Competitor "A" PCD Mill 6"
Spindle Speed (RPM)	10,000	5,000
Feed Rate (in/min)	400	100
Depth of Cut	.020 in.	.020 in.
Effective Teeth	10	9
Cycle Time (minutes)	27	103
Tool Life (pieces)	85,000	35,000

<i>Rough Milling Aluminum Crank Case</i>		
	PCD Tedimill 4"	Competitor "A" PCD Mill 4"
Spindle Speed (RPM)	5,000	2,500
Feed Rate (in/min)	160	80
Depth of Cut	.090 in.	.090 in.
Effective Teeth	8	6
Cycle Time (minutes)	68	136
Tool Life (pieces)	68,000	12,000

PRODUCT NEWS

PCD SHELL TYPE CUTTERS - INCH

All Items in Red Are
NOW IN STOCK!

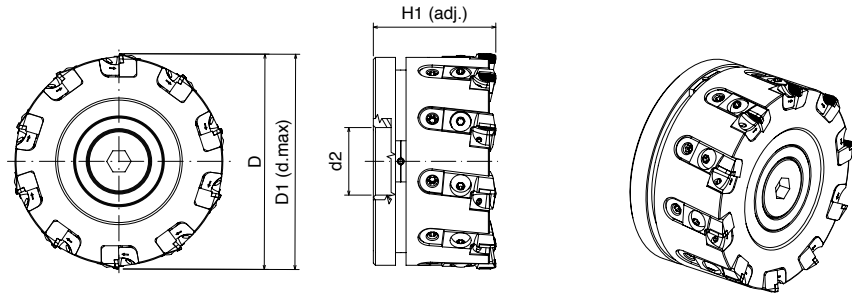

Item Number	d2 (MM)	Holder Shape	D Ø nom. (INCH)	D1 (INCH)	Z	H1	Material	Rotation
FIP020R040A	22	A	2.00	2.055	4	2.165	Aluminum	R
FIP020R050S	22	A	2.00	2.055	5	2.165	Steel	R
FIP025R050A	22	B	2.50	2.555	5	2.165	Aluminum	R
FIP025R060A	22	B	2.50	2.555	6	2.165	Aluminum	R
FIP030R050A	27	A	3.00	3.055	5	2.283	Aluminum	R
FIP030R060A	27	A	3.00	3.055	6	2.283	Aluminum	R
FIP030R080A	27	A	3.00	3.055	8	2.283	Aluminum	R
FIP040R080A	32	A	4.00	4.055	8	2.283	Aluminum	R
FIP040R120T	32	A	4.00	4.055	12	2.283	Titanium	R
FIP050R100A	40	A	5.00	5.055	10	2.283	Aluminum	R
FIP050R160T	40	A	5.00	5.055	16	2.283	Titanium	R
FIP060R100A	40	C	6.00	6.055	10	2.283	Aluminum	R
FIP060R180A	40	C	6.00	6.055	18	2.283	Aluminum	R
NEW FIP070R200A	40	C	7.00	7.055	20	2.283	Aluminum	R
FIP080R120A	60	C	8.00	8.055	12	2.48	Aluminum	R
FIP080R240A	60	C	8.00	8.055	24	2.48	Aluminum	R
FIP100R160A	60	C	10.00	10.055	16	2.48	Aluminum	R
FIP100R300A	60	C	10.00	10.055	30	2.48	Aluminum	R

PRODUCT NEWS

CUTTER HOLDERS - METRIC

HOLDER HSK A
DIN 69893

All Items in Red Are
NOW IN STOCK!

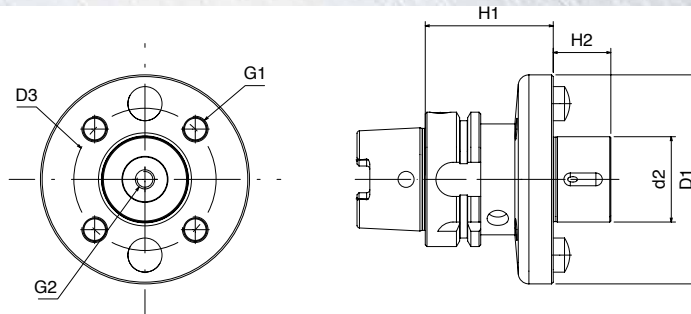

Item Number	HSK Taper Dimension	Holder Shape	d2	H1	D1	D3	H2	G1	G2
APHK40AA16050	A 40	A	16	50	41	-	13	-	M6
APHK40BA22050	A 40	B	22	50	58	-	19	-	M10
APHK40AA22050	A 40	A	22	50	50	-	19	-	M10
APHK50AA16050	A 50	A	16	50	41	-	13	-	M6
APHK50AA16100	A 50	A	16	100	41	-	13	-	M6
APHK50BA22050	A 50	B	22	50	58	-	19	-	M10
APHK50AA22050	A 50	A	22	50	50	-	19	-	M10
APHK50BA22100	A 50	B	22	100	58	-	19	-	M10
APHK50AA22100	A 50	A	22	100	50	-	19	-	M10
APHK50AA27060	A 50	A	27	60	68	-	21	-	M12
APHK50AA27100	A 50	A	27	100	68	-	21	-	M12
APHK63AA16050	A 63	A	16	50	41	-	13	-	M6
APHK63AA16100	A 63	A	16	100	41	-	13	-	M6
APHK63BA22050	A 63	B	22	50	58	-	19	-	M10
APHK63AA22050	A 63	A	22	50	50	-	19	-	M10
APHK63BA22100	A 63	B	22	100	58	-	19	-	M10
APHK63AA22100	A 63	A	22	100	50	-	19	-	M10
APHK63AA27060	A 63	A	27	60	68	-	21	-	M12
APHK63AA27100	A 63	A	27	100	68	-	21	-	M12
APHK63AA32060	A 63	A	32	60	88	-	24	-	M16
APHK63AA32100	A 63	A	32	100	88	-	24	-	M16
APHK63AA40060	A 63	A	40	60	98	-	27	-	M20
APHK63AA40100	A 63	A	40	100	98	-	27	-	M20
APHK63CA40060	A 63	C	40	60	98	66.7	27	M12	-
APHK80AA16060	A 80	A	16	60	41	-	13	-	M6

PRODUCT NEWS

CUTTER HOLDERS - METRIC

HOLDER HSK A
DIN 69893

All Items in Red Are
NOW IN STOCK!

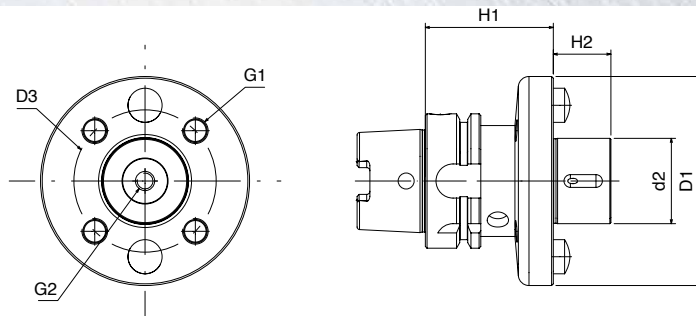

Item Number	HSK Taper Dimension	Holder Shape	d2	H1	D1	D3	H2	G1	G2
APHK80AA16120	A 80	A	16	120	41	-	13	-	M6
APHK80BA22060	A 80	B	22	60	58	-	19	-	M10
APHK80AA22060	A 80	A	22	60	50	-	19	-	M10
APHK80BA22120	A 80	B	22	120	58	-	19	-	M10
APHK80AA22120	A 80	A	22	120	50	-	19	-	M10
APHK80AA27060	A 80	A	27	60	68	-	21	-	M12
APHK80AA27120	A 80	A	27	120	68	-	21	-	M12
APHK80AA32060	A 80	A	32	60	88	-	24	-	M16
APHK80AA32120	A 80	A	32	120	88	-	24	-	M16
APHK80AA40060	A 80	A	40	60	98	-	27	-	M20
APHK80AA40120	A 80	A	40	120	98	-	27	-	M20
APHK80CA40060	A 80	C	40	60	98	66.7	27	M12	-
APHK80CA60060	A 80	C	60	60	140	101.6	40	M16	-
APHK10BA22060	A 100	B	22	60	58	-	19	-	M10
APHK10AA22060	A 100	A	22	60	50	-	19	-	M10
APHK10BA22120	A 100	B	22	120	58	-	19	-	M10
APHK10AA22120	A 100	A	22	120	50	-	19	-	M10
APHK10AA27060	A 100	A	27	60	68	-	21	-	M12
APHK10AA27120	A 100	A	27	120	68	-	21	-	M12
APHK10AA32070	A 100	A	32	70	88	-	24	-	M16
APHK10AA32120	A 100	A	32	120	88	-	24	-	M16
APHK10AA40070	A 100	A	40	70	98	-	27	-	M20
APHK10AA40120	A 100	A	40	120	98	-	27	-	M20
APHK10CA40070	A 100	C	40	70	98	66.7	27	M12	-
APHK10CA60070	A 100	C	60	70	140	101.6	40	M16	-

PRODUCT NEWS

CUTTER HOLDERS - METRIC

HOLDER CAT A/B

All Items in Red Are
NOW IN STOCK!

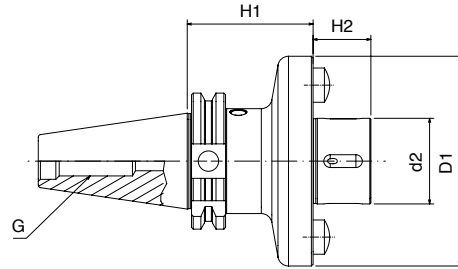
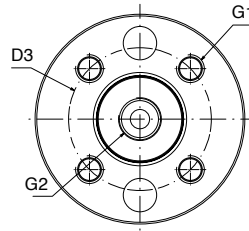

Item Number	CAT Taper Dimension	Holder Shape	d2	H1	D1	D3	H2	G1	G2
API740AC22050	40	A	22	50	50	-	19	-	M10
API740AC22100	40	A	22	100	50	-	19	-	M10
API740BC22050	40	B	22	50	58	-	19	-	M10
API740BC22100	40	B	22	100	58	-	19	-	M10
API740AC27060	40	A	27	60	68	-	21	-	M12
API740AC27100	40	A	27	100	68	-	21	-	M12
API740AC32060	40	A	32	60	88	-	24	-	M16
API740AC32100	40	A	32	100	88	-	24	-	M16
API740AC40060	40	A	40	60	98	-	27	-	M20
API740AC40100	40	A	40	100	98	-	27	-	M20
API740CC40060	40	C	40	60	98	66.7	27	M12	-
API740CC40100	40	C	40	60	98	66.7	27	M12	-
API750AC22060	50	A	22	60	50	-	19	-	M10
API750AC22120	50	A	22	120	50	-	19	-	M10
API750BC22060	50	B	22	60	58	-	19	-	M10
API750BC22120	50	B	22	120	58	-	19	-	M10
API750AC27060	50	A	27	60	68	-	21	-	M12
API750AC27120	50	A	27	120	68	-	21	-	M12
API750AC32070	50	A	32	70	88	-	24	-	M16
API750AC32120	50	A	32	120	88	-	24	-	M16
API750AC40070	50	A	40	70	98	-	27	-	M20
API750AC40120	50	A	40	120	98	-	27	-	M20
API750CC40070	50	C	40	70	98	66.7	27	M12	-
API750CC40120	50	C	40	120	98	66.7	27	M12	-
API750CC60070	50	C	60	70	140	101.6	30	M16	-
API750CC60120	50	C	60	120	140	101.6	30	M16	-

PRODUCT NEWS

ADAPTORS - METRIC

HOLDER BT A/B
MAS 403

All Items in Red Are
NOW IN STOCK!

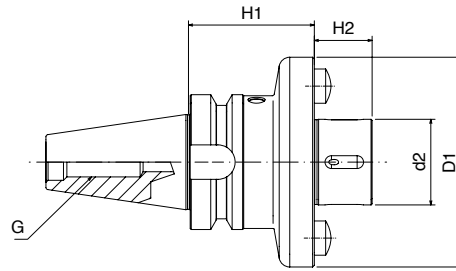
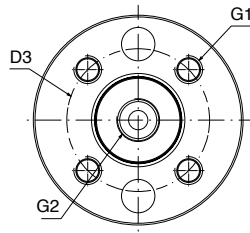

Item Number	BT Taper Dimension	Holder Shape	d2	H1	D1	D3	H2	G1	G2
NEW API430AA16050	30	A	16	50	41	-	13	-	M6
NEW API430BA22050	30	B	22	50	50	-	19	-	M10
NEW API430AA22050	30	A	22	50	50	-	19	-	M10
NEW API430AA27060	30	A	27	60	68	-	21	-	M12
NEW API430AA32060	30	A	32	60	88	-	24	-	M16
API440AC16050	40	A	16	50	41	-	13	-	M6
API440AC16100	40	A	16	100	41	-	13	-	M6
API440BC22050	40	B	22	50	58	-	19	-	M10
API440AC22050	40	A	22	50	50	-	19	-	M10
API440BC22100	40	B	22	100	58	-	19	-	M10
API440AC22100	40	A	22	100	50	-	19	-	M10
API440AC27060	40	A	27	60	68	-	21	-	M12
API440AC27100	40	A	27	100	68	-	21	-	M12
API440AC32060	40	A	32	60	88	-	24	-	M16
API440AC32100	40	A	32	100	88	-	24	-	M16
API440AC40060	40	A	40	60	98	-	27	-	M20
API440AC40100	40	A	40	100	98	-	27	-	M20
API440CC40060	40	C	40	60	98	66.7	27	M12	-
API450BC22060	50	B	22	60	58	-	19	-	M10
API450AC22060	50	A	22	60	50	-	19	-	M10
API450BC22120	50	B	22	120	58	-	19	-	M10
API450AC22120	50	A	22	120	50	-	19	-	M10
API450AC27060	50	A	27	60	68	-	21	-	M12
API450AC27120	50	A	27	120	68	-	21	-	M12
API450AC32070	50	A	32	70	88	-	24	-	M16
API450AC32120	50	A	32	120	88	-	24	-	M16
API450AC40070	50	A	40	70	98	-	27	-	M20
API450AC40120	50	A	40	120	98	-	27	-	M20
API450CC40070	50	C	40	70	98	66.7	27	M12	-
API450CC60070	50	C	60	70	140	101.6	40	M16	-