

Ideal for Live Tooling and Swiss!



Diameters:
.750" - 2.00"

Cutter Series:
1TJ1C

Insert Series:
ENHU05 (5mm I.C.)

Materials:
Cast Iron, Steel, Stainless Steel,
Hardened Steel, High-Temp Alloys

Depth of Cut:
.18"

Big Head and Small Adaption...Easiest Loading Micro Insert on the Market.

- *Double-Dovetail-Pocket clamps insert in pocket while affixing the screw. Easy loading!*
- *Double-Dovetail-Pocket promotes stable insert mounting. Low stress on screw!*
- *Straight-Shank cutter design for spring collet systems*
- *Modular design with Solid-ER-Shank promotes blend of quick-change and rigidity.*

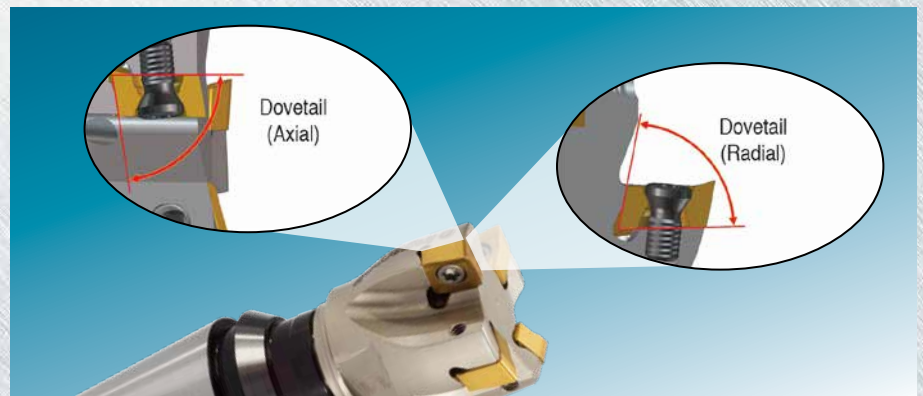

**PRODUCT
ANNOUNCEMENT
UPDATE
2018**

SERIES 1TJ1C (CYLINDRICAL STYLE) (5MM)

90° END MILL WITH 2 INDEXES (SHANK FOR LIVE TOOLING & SWISS)

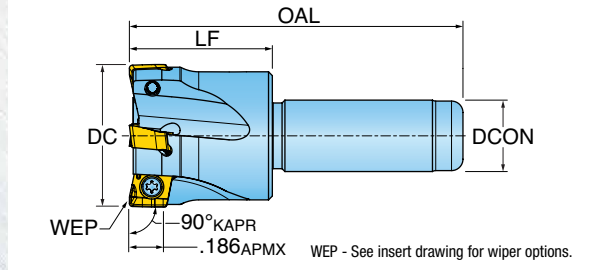
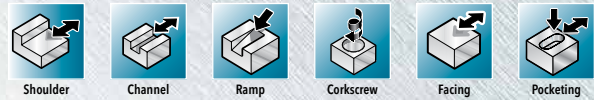

Part Number	DC Cutting Dia.	LF Functional Length	OAL Overall Length	ZEFF Effective Teeth	DCON Shank Dia.	RMPX Ramp Angle Max.
1TJ1C-0700777R01	0.750	0.75	1.75	4	0.375	3.3
1TJ1C-1000777R01	1.000	0.75	1.75	5	0.375	2.2
1TJ1C-1500754R01	1.500	0.75	1.75	7	0.500	1.3
1TJ1C-2000756R01	2.000	0.75	1.75	7	0.625	.9

INSERTS & HARDWARE (5MM)

ENHU05R

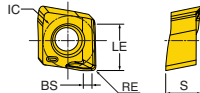

ENHU05R-PH

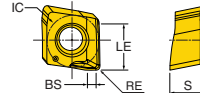

Part Number	RE/BCH Corner Radius/Chamfer	BS Wiper Length	LE Cutting Edge Length	IC Inscribed Circle Dia.	S Thickness (To Cutting Edge)	NOI Number of Indexes	IH Insert Hand	Grade	IN2504	IN2505	IN2510	IN2530	IN6515	IN7035
ENHU050302R	0.008 R	0.030	0.180	0.203	0.133	2	Right			•	•			
ENHU050304R	0.015 R	0.030	0.180	0.203	0.133	2	Right		•	•	•	•	•	
ENHU050308R	0.031 R	0.015	0.180	0.203	0.133	2	Right		•	•	•	•	•	
ENHU050304R-PH	0.015 R	0.030	0.180	0.203	0.133	2	Right							•
ENHU050308R-PH	0.031 R	0.015	0.180	0.203	0.133	2	Right			•				•



Screw

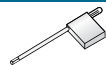

Driver



Optional Torque Driver Handle



Optional Bit

1TJ1C	SM20-043-00	DS-TP06S-NEU	DTN005S	DS-TP06TB
-------	-------------	--------------	---------	-----------

SERIES 1TJ1C (T-ADAPTION STYLE) (5MM)

90° MODULAR END MILL WITH 2 INDEXES

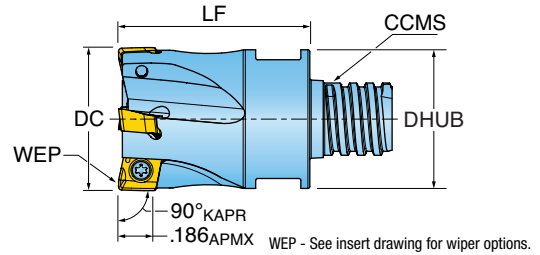

Part Number	DC Cutting Dia.	LF Functional Length	ZEFF Effective Teeth	CCMS Connection Code	DHUB Hub Dia.	CSP Coolant	RMPX Ramp Angle Max.
1TJ1C-07007T8R01	0.750	0.75	4	Chip Surfer T08	.48	No	3.3
1TJ1C-10007T8R01	1.000	0.75	5	Chip Surfer T08	.48	No	2.2

INSERTS & HARDWARE (5MM)

ENHU05R

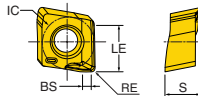

ENHU05R-PH

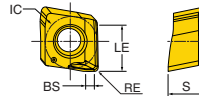

Part Number	RE/BCH Corner Radius/Chamfer	BS Wiper Length	LE Cutting Edge Length	IC Inscribed Circle Dia.	S Thickness (To Cutting Edge)	NOI Number of Indexes	IH Insert Hand	Grade	IN2504	IN2505	IN2510	IN2530	IN6515	IN7035
ENHU050302R	0.008 R	0.030	0.180	0.203	0.133	2	Right			•		•		
ENHU050304R	0.015 R	0.030	0.180	0.203	0.133	2	Right		•	•	•	•	•	
ENHU050308R	0.031 R	0.015	0.180	0.203	0.133	2	Right		•	•	•	•	•	
ENHU050304R-PH	0.015 R	0.030	0.180	0.203	0.133	2	Right							•
ENHU050308R-PH	0.031 R	0.015	0.180	0.203	0.133	2	Right			•		•		•

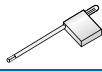

Screw

Driver

Thin Wrench

Optional Torque Driver Handle

Optional Bit

1TJ1C-05006T8R01	SM20-043-00	DS-TP06S-NEU	WS-0030	DTN005S	DS-TP06TB
1TJ1C-06008TRR01	SM20-043-00	DS-TP06S-NEU	WS-0044	DTN005S	DS-TP06TB
1TJ1C-07007T8R01	SM20-043-00	DS-TP06S-NEU	WS-0030	DTN005S	DS-TP06TB
1TJ1C-07010TSR01	SM20-043-00	DS-TP06S-NEU	WS-0059	DTN005S	DS-TP06TB
1TJ1C-10007T8R01	SM20-043-00	DS-TP06S-NEU	WS-0059	DTN005S	DS-TP06TB
1TJ1C-10012TUR01	SM20-043-00	DS-TP06S-NEU	WS-0061	DTN005S	DS-TP06TB

SERIES ER*SA CHIP-SURFER (5MM)

SOLID ER SHANK (SIMULTANEOUS FIT "T" STYLE ADAPTION)

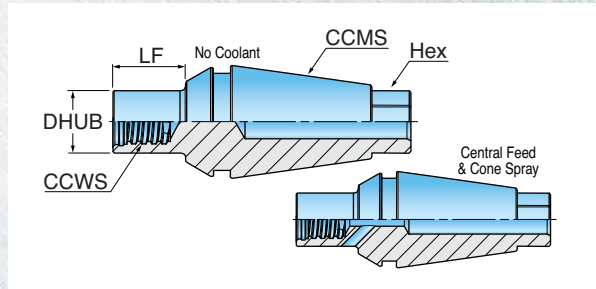
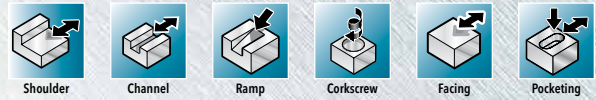

Part Number	CCWS Connection Code Workpiece Side	DHUB Hub Dia.	LF Functional Length	CCMS Connection Code Machine Side	CSP Coolant Delivery
ER16T08SA-02	Chip Surfer T08	0.457	0.16	ER16	No Coolant
ER16T08SA-06	Chip Surfer T08	0.457	0.51	ER16	No Coolant

When assembling, be sure carbide tip is seated firmly on shank with no gap.
 Note: DO NOT apply lubricant to the thread connection.

OPERATING GUIDELINES

DiPos TETRA - Series 1TJ1C, TJ1C					IN7035	IN2504	IN2505	IN2510	IN2530	IN6515	Coolant
Material	Brinnell Hardness	SFM	Feed per Insert								
Cast Iron	Gray	150 - 250	300 - 1000	.003 - .007				1		2	No
	Nodular		300 - 600					2		1	
Steel	Low Carbon 1018, 8620	100 - 250	400 - 1000	.003 - .007							No
	High Carbon F-6180	250 - 400	350 - 500								
	Alloyed Steel 4140, 4340	150 - 300	300 - 700				2		1		
	Tool Steel A-6, D-1, D-2	Up to 300									
Stainless Steel	300 Series, 304, 316	-	300 - 550	.002 - .005	1				2		May not be required at high speeds
	400 Series 15-5 PH	Up to 320	350 - 600								
	13-8 PH	-	200 - 400								
Nickel Alloys	Inconel, Hastelloy, Waspalloy	-	75-120	.002 - .005	1		3		2		Yes
Titanium	6AL-4V	-	100 - 150	.002 - .005	1		3		2		Yes
Hardened Steel	All	-	165 - 360	.002 - .005		1	2				Yes

DRILL MILL POCKETING

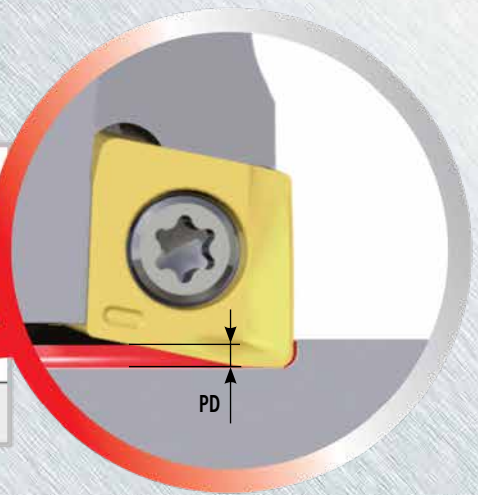
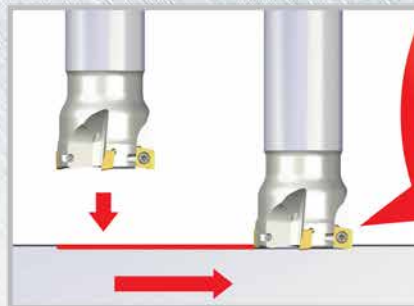
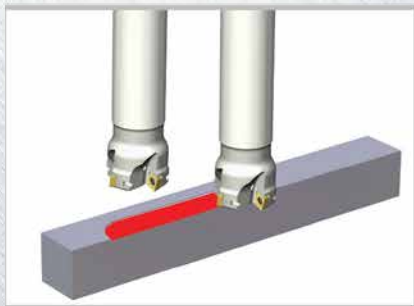

DC Cutting Dia.	PD Plunge Depth
0.500	0.027
0.650	0.027
0.750	0.027
1.000	0.027
1.500	0.027
2.000	0.027

STRAIGHT RAMPING DATA

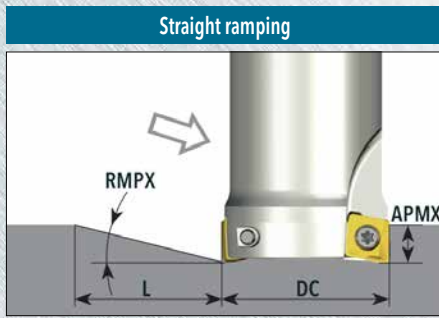

DC Cutting Dia.	RMPX Ramping Angle	L	APMX
0.500	6.9	1.48	0.18
0.650	4.4	2.34	0.18
0.750	3.3	3.12	0.18
1.000	2.2	4.68	0.18
1.500	1.3	7.93	0.18
2.000	0.9	11.45	0.18

HELICAL RAMPING DATA

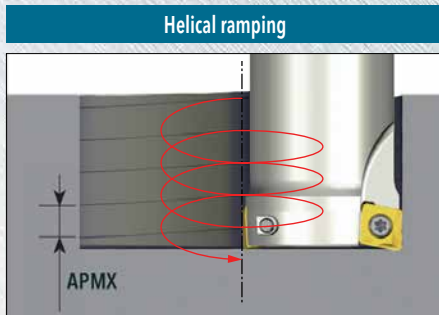

DC Cutting Dia.	MIN. Diameter Milled Hole	MIN. Advance Per Cutter Path Rev. (APCPR)	MAX. Diameter Milled Hole	APMX/Rev.
0.500	0.61	0.041	1.00	0.180
0.650	0.86	0.057	1.25	0.150
0.750	1.11	0.065	1.50	0.135
1.000	1.60	0.072	2.00	0.120
1.500	2.60	0.078	3.00	0.180
2.000	3.60	0.078	4.00	0.098

INDEXING CHIP-SURFER TIPS

- Step 1: Screw tip into shank until finger tight (Figure 1a). Note a .010" gap (Figure 1b).
- Step 2: Use wrench to torque approximately 1/4 turn, creating a simultaneous fit (Figure 2).
- Step 3: Use .001" shim stock to check the simultaneous fit at the intersection of the tip and the shank. The shim should not be able to enter the intersection (Figure 3a). If it does, tighten further with the wrench until there is no gap (Figure 3b).

Note: Pre-set torque wrenches (series DT- . . .) can be purchased.



ASSEMBLING SOLID ER CHIP-SURFER SHANKS



WRONG WAY



Remove nut from ER holder



Place ER shank in holder



Screw the nut on the holder

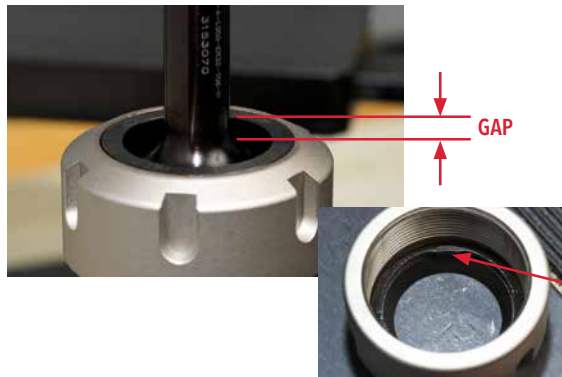

The nut will BIND up on the retention tabs prematurely - leaving a gap. Extra force may break the nut.



RIGHT WAY



Place the nut on the ER shank



Assemble the nut with the shank by mating the Retention Tabs with the ER Groove



Place the nut/shank assembly into the holder

