

TOP•ON™

Ingersoll introduces integral CAT50
 Top•On Master Shanks available in a
 variety of lengths and all thread offerings.



NEW

**M08, M10, M12
 and M16 Threads
 NOW AVAILABLE!!**

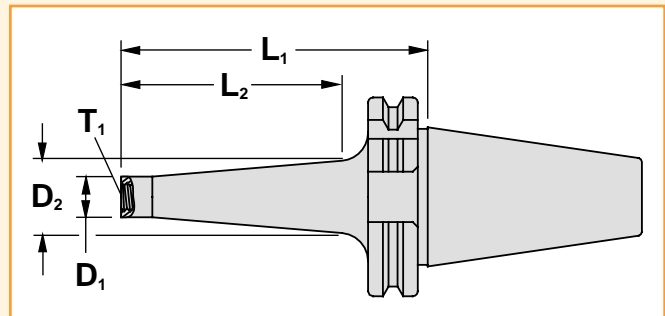

Item Number	Part Number	Thread T1	Connection Diameter D1	Projection Diameter D2	Extension Length L1	Projection Length L2
4543234	CAT50ODPM8X5.000	M8	0.510	0.910	5.00	3.56
4543235	CAT50ODPM10X3.000	M10	0.710	0.710	3.00	1.56
4543236	CAT50ODPM10X7.000	M10	0.710	1.100	7.00	5.56
4543237	CAT50ODPM12X3.000	M12	0.830	0.830	3.00	1.56
4543238	CAT50ODPM12X7.000	M12	0.830	1.220	7.00	5.56
4543239	CAT50ODPM16X3.000	M16	1.140	1.140	3.00	1.56
4543240	CAT50ODPM16X7.000	M16	1.140	1.340	7.00	5.56