

OPERATING GUIDELINES 9MM

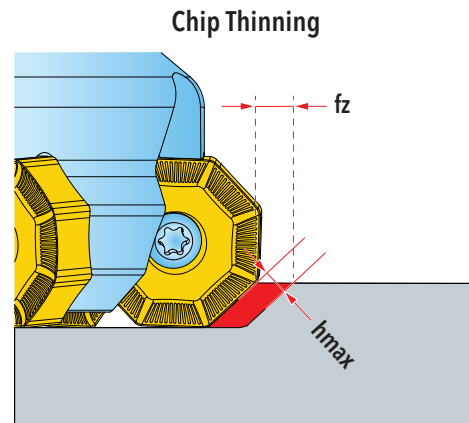

* Chip Thinning Calculator is recommended to ensure hmax is greater than .003"

ISO	Materials			Vc Cutting Speed SFM	fz* Feed/ Tooth (inch)	Harder <-----> Tougher										Coolant				
	Mat'l Group #VDI 3323	Type	Examples			Ceramic		Carbide												
						IN70N	IN2004	IN2015	IN6515	IN10K	IN2010	IN2510	IN4010	IN6510	IN2040		IN2005	IN2505	IN4005	IN2030
P	1-5	Non-alloy Steel	1018, A36, 1045, A572, 1070	400-1000	.006 - .012															No
	6-9	Low-alloy Steel	4140, 4340, P20, 8620, 300M	300-700		3	2	1	4											
	10, 11	High-alloy Steel	H13, A2, D2, M2, T1	300-500																
M	12-13	Stainless Steel (Ferritic & Martensitic)	400, 416, 440	300-700	.005-.009														May not be required at high speeds	
	14	Stainless Steel (Martensitic)	303, 304, 316, 15-5, 17-4	400-700		3	2	1												
13-8 PH			200-400															Yes		
K	15-16	Gray Cast Iron	CLS. 20, 30, 45	500-1000	.008-.016	3	2	1									4	No		
				1800+	.005-.008	1														
	17-18	Nodular Cast Iron	60-40-18, 100-70-03	400-800	.007-.014	3	1	2									4			
1500+				.004-.007	1															
N	21-30	Aluminum	7075, 6061	1500-10000	.006-.012				1									Yes		
S	31-35	High-Temp Alloys	Inconel, Hastelloy, Nimonic, Monel	75-120	.003-.006								2	3	1	Yes				
	36-37	Titanium Alloys	6Al-4V, 5Al-5Mo-5V-3Cr	100-150	.004-.007								3	2	1					

Note: Feed and speed recommendations are starting operating parameters. They are only guidelines from which further optimization should take place. Operating parameters are influenced by many machining variables. These variables may cause for reductions in feeds and speed or dramatic increases. Additionally, DOC and WOC may need to be revised to optimize the tools performance.