



DEEPTRIO™

DRILLING PRODUCTS

Drilling Range:
 Ø .313-1.575" (7.94mm-40mm)

Thread Types:
 STS Outer four start thread
 STS Inner single start thread
 DTS Outer four start thread

Insert Grades*:
 IN2005**
 IN2055
 IN05S

Chip Breakers:
 "DT" - Standard
 "DT-P" - Aluminum Applications
 "ML" - Low Feed/Power Applications

Guide Pads*:
 IN2040 (CD-SA) - Solid carbide pad, high wear resistance
 IN2005 (CD-SB) - Solid carbide pad, high toughness
 IN2030 (CD-SC) - Solid carbide pad, higher toughness

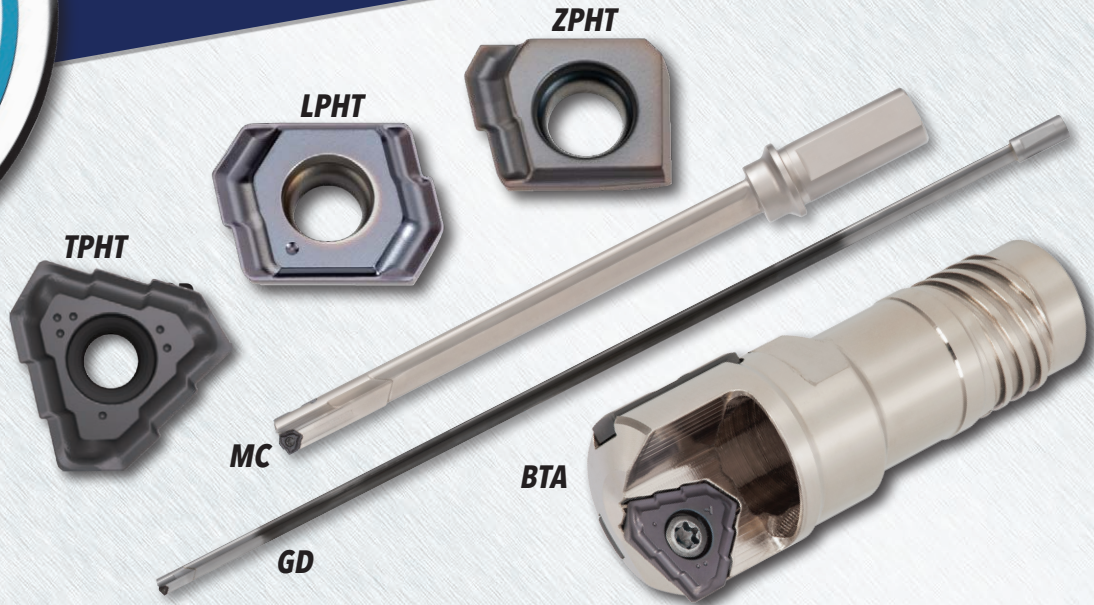

An Extensive Family of Deep Hole Drilling Tools

- DEEPTRIO^{MC}** - Conventional style drill for lathes or mills, Conventional cross-hole style drill for lathes or mills
 Standard lengths 10xD, 15xD and 25xD
 Diameter range: .313-1.260" (7.94-32 mm) **NEW**
- DEEPTRIO^{GD}** - Gundrill style
 Gundrill cross-hole style
 Both styles offer lengths up to 94.488" OAL (2400 mm)
 Diameter range: .313-1.260" (7.94-32 mm) **NEW**
- DEEPTRIO^{BTA}** - BTA drilling head available for STS & DTS systems
 Diameter range: .551-1.575" (14-40 mm)

Features & Benefits:

- Expanded diameter range: .313" (7.94 mm)-1.575" (40 mm)
- Excellent hole accuracy (IT10) and surface finish
- Very high feed rates
- Replaceable inserts provide long tool life and eliminate regrinding
- Cross-holes up to 1.259" (32 mm) diameter
- Diameter adjusting shims
- Available in two chip breakers
- TRH replacement heads for brazing

*Guide pads and inserts must be purchased separately.
 **IN2005 to be phased out as stock is depleted.

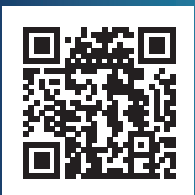



DEEPTRIOMC™ CONVENTIONAL DRILLS: 10XD

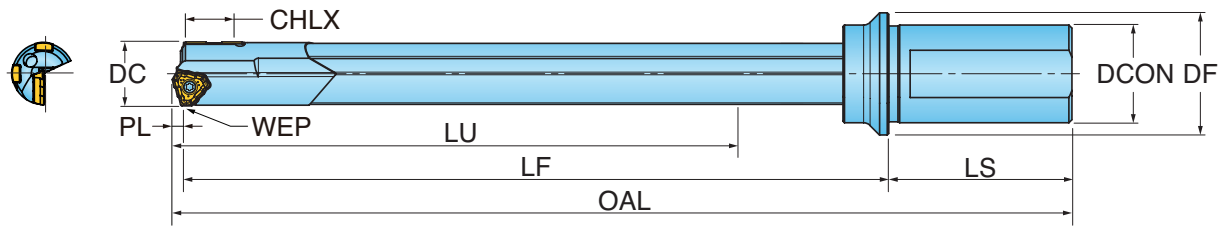

INCH

Part Number	DC Cutting Dia.	PL Point Length	CHLX Cross-Hole Length Max.	LU Usable Length Max.	LF Functional Length	LS Shank Length	OAL Overall Length	DCON Connection Dia.	DF Flange Dia.	ULDR Usable Length Dia. Ratio
GT14680146N5R01	0.578	0.079	0.63	5.91	7.36	2.21	9.65	1.000	1.26	10
GT15060146N5R01	0.593	0.079	0.63	6.30	7.80	2.21	10.08	1.000	1.26	10
GT15880160N5R01	0.625	0.079	0.63	6.30	7.84	2.21	10.12	1.000	1.26	10
GT17450175N5R01	0.687	0.087	0.63	7.17	8.66	2.21	10.95	1.000	1.26	10
GT18240182N5R01	0.718	0.118	0.63	7.60	9.13	2.21	11.46	1.000	1.26	10
GT18640186N5R01	0.734	0.118	0.63	7.60	9.13	2.21	11.46	1.000	1.26	10
GT19050191N5R01	0.750	0.118	0.63	7.99	9.57	2.21	11.89	1.000	1.26	10
GT20620206N6R01	0.812	0.126	0.63	8.39	10.04	2.36	12.53	1.250	1.57	10
GT22230222N6R01	0.875	0.134	0.63	9.19	10.95	2.36	13.44	1.250	1.57	10
GT23800238N6R01	0.937	0.134	0.63	9.98	11.85	2.36	14.34	1.250	1.57	10
GT25400254N6R01	1.000	0.134	0.63	10.38	12.28	2.36	14.78	1.250	1.57	10
GT26970270N6R01	1.062	0.146	0.63	11.17	13.19	2.36	15.70	1.250	1.57	10
GT28580285N6R01	1.125	0.181	0.63	11.42	14.17	2.36	16.71	1.250	1.57	10
GT29360285N6R01	1.156	0.181	0.63	11.81	14.65	2.36	17.19	1.250	1.57	10
GT31750318N6R01	1.250	0.181	0.63	12.60	15.55	2.36	18.09	1.250	1.57	10

METRIC

Part Number	DC Cutting Dia.	PL Point Length	CHLX Cross-Hole Length Max.	LU Usable Length Max.	LF Functional Length	LS Shank Length	OAL Overall Length	DCON Connection Dia.	DF Flange Dia.	ULDR Usable Length Dia. Ratio
GT16000160JFR02	16.00	2.20	16.0	172.2	209.0	56.0	267.2	25.00	32	10
GT16500160JFR02	16.50	2.20	16.0	172.2	209.0	56.0	267.2	25.00	32	10
GT17000170JFR02	17.00	2.20	16.0	182.2	220.0	56.0	278.2	25.00	32	10
GT18000180JFR02	18.00	2.20	16.0	192.2	232.0	56.0	290.2	25.00	32	10
GT19000190JFR01	19.00	3.00	16.0	203.0	243.0	56.0	302.0	25.00	32	10
GT20000200JGR01	20.00	3.00	16.0	213.0	255.0	60.0	318.0	32.00	40	10
GT21000210JGR01	21.00	3.20	16.0	223.2	266.0	60.0	329.2	32.00	40	10
GT22000220JGR01	22.00	3.40	16.0	233.4	278.0	60.0	341.4	32.00	40	10
GT23000230JGR01	23.00	3.40	16.0	243.4	289.0	60.0	352.4	32.00	40	10
GT24000240JGR01	24.00	3.40	16.0	253.4	301.0	60.0	364.4	32.00	40	10
GT25000250JGR01	25.00	3.40	16.0	263.4	312.0	60.0	375.4	32.00	40	10
GT26000260JHR01	26.00	3.60	16.0	273.7	324.0	70.0	397.6	40.00	50	10
GT27000270JHR01	27.00	3.60	16.0	283.7	335.0	70.0	408.6	40.00	50	10
GT28000280JHR01	28.00	3.60	16.0	283.7	337.0	70.0	410.6	40.00	50	10



DEEPTRIOMC™ CONVENTIONAL DRILLS: 15XD (INCH)

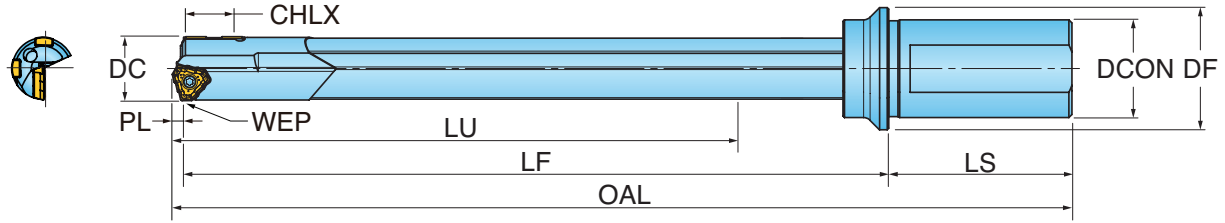

INCH

NEW

Part Number	DC Cutting Dia.	PL Point Length	CHLX Cross-Hole Length Max.	LU Usable Length Max.	LF Functional Length	LS Shank Length	OAL Overall Length	DCON Connection Dia.	DF Flange Dia.	ULDR Usable Length Dia. Ratio
GT09530146N4R01	0.375	0.045	0.45	6.61	7.513	1.97	9.48	0.750	0.98	15
GT11110180N4R01	0.437	0.071	0.63	7.16	8.23	1.97	10.27	0.750	0.98	15
GT12700190N5R01	0.500	0.071	0.63	7.75	9.02	2.21	11.29	1.000	1.26	15
GT13490202N5R01	0.531	0.071	0.63	8.34	9.65	2.21	11.92	1.000	1.26	15
GT14270225N5R01	0.562	0.079	0.63	8.94	10.28	2.21	12.56	1.000	1.26	15
GT14680225N5R01	0.578	0.079	0.63	8.94	10.32	2.21	12.60	1.000	1.26	15
GT15060225N5R01	0.593	0.079	0.63	9.53	10.95	2.21	13.23	1.000	1.26	15
GT15880240N5R01	0.625	0.079	0.63	9.53	10.98	2.21	13.27	1.000	1.26	15
GT17450262N5R02	0.687	0.087	0.63	10.72	12.21	2.21	14.50	1.000	1.26	15
GT18240274N5R01	0.718	0.118	0.63	11.34	12.87	2.21	15.20	1.000	1.26	15
GT18640280N5R01	0.734	0.118	0.63	11.34	12.87	2.21	15.20	1.000	1.26	15
GT19050286N5R01	0.750	0.118	0.63	11.93	13.50	2.21	15.83	1.000	1.26	15
GT20620309N6R01	0.812	0.126	0.63	12.53	14.17	2.36	16.66	1.250	1.57	15
GT22230333N6R01	0.875	0.134	0.63	13.72	15.47	2.36	17.97	1.250	1.57	15
GT23800357N6R01	0.937	0.134	0.63	10.96	16.77	2.36	19.27	1.250	1.57	15
GT25400381N6R01	1.000	0.146	0.63	15.50	17.40	2.36	19.91	1.250	1.57	15
GT26970405N6R01	1.062	0.146	0.63	16.68	18.70	2.36	21.21	1.250	1.57	15
GT28580428N6R01	1.125	0.181	0.63	17.13	19.88	2.36	22.42	1.250	1.57	15
GT29360429N6R01	1.156	0.181	0.63	17.72	20.55	2.36	23.09	1.250	1.57	15
GT31750476N6R01	1.250	0.181	0.63	18.90	21.85	2.36	24.39	1.250	1.57	15



DEEPTRIOMC™ CONVENTIONAL DRILLS: 15XD (METRIC)

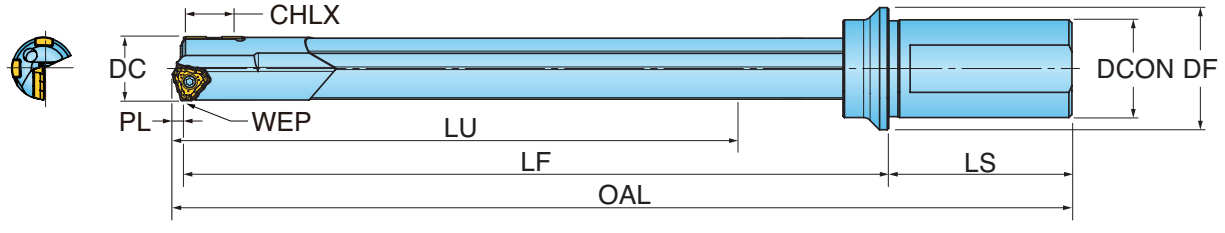

METRIC

Part Number	DC Cutting Dia.	PL Point Length	CHLX Cross-Hole Length Max.	LU Usable Length Max.	LF Functional Length	LS Shank Length	OAL Overall Length	DCON Connection Dia.	DF Flange Dia.	ULDR Usable Length Dia. Ratio
GT10000158JER01	10.00	1.80	16.0	159.3	184.5	50.0	236.3	20.00	25	15
GT10500165JER01	10.50	1.80	16.0	166.8	193.0	50.0	244.8	20.00	25	15
GT11000180JER01	11.00	1.80	16.0	181.8	209.0	50.0	260.8	20.00	25	15
GT11500180JER01	11.50	1.80	16.0	181.8	209.0	50.0	260.8	20.00	25	15
GT12000197JER01	12.00	1.80	16.0	196.8	225.0	50.0	276.8	20.00	25	15
GT12500197JER01	12.50	1.80	16.0	196.8	226.0	50.0	277.8	20.00	25	15
GT13000212JFR01	13.00	1.80	16.0	211.8	245.0	56.0	302.8	25.00	32	15
GT13500212JFR01	13.50	1.80	16.0	211.8	245.0	56.0	302.8	25.00	32	15
GT14000225JFR01	14.00	2.00	16.0	227.0	245.0	56.0	303.0	25.00	32	15
GT14500225JFR01	14.50	2.00	16.0	227.0	262.0	56.0	320.0	25.00	32	15
GT15000240JFR01	15.00	2.00	16.0	242.0	278.0	56.0	336.0	25.00	32	15
GT16000240JFR02	16.00	2.20	16.0	257.2	294.0	56.0	352.2	25.00	32	15
GT16500248JFR02	16.50	2.20	16.0	257.2	294.0	56.0	352.2	25.00	32	15
GT17000255JFR02	17.00	2.20	16.0	272.2	310.0	56.0	368.2	25.00	32	15
GT17500263JFR02	17.50	2.20	16.0	272.2	310.0	56.0	368.2	25.00	32	15
GT18000270JFR02	18.00	2.20	16.0	287.2	327.0	56.0	385.2	25.00	32	15
GT18500278JFR01	18.50	3.00	16.0	288.0	327.0	56.0	386.0	25.00	32	15
GT19000285JFR01	19.00	3.00	16.0	303.0	343.0	56.0	402.0	25.00	32	15
GT19500293JFR01	19.50	3.00	16.0	303.0	343.0	56.0	402.0	25.00	32	15
GT20000300JGR01	20.00	3.00	16.0	318.0	360.0	60.0	423.0	32.00	40	15
GT21000315JGR01	21.00	3.20	16.0	333.2	376.0	60.0	439.2	32.00	40	15
GT22000330JGR01	22.00	3.40	16.0	348.4	393.0	60.0	456.4	32.00	40	15
GT23000345JGR01	23.00	3.40	16.0	363.4	409.0	60.0	472.4	32.00	40	15
GT24000360JGR01	24.00	3.40	16.0	378.4	426.0	60.0	489.4	32.00	40	15
GT25000375JGR01	25.00	3.40	16.0	393.4	442.0	60.0	505.4	32.00	40	15
GT26000390JHR01	26.00	3.60	16.0	408.7	459.0	70.0	532.6	40.00	50	15
GT27000405JHR01	27.00	3.60	16.0	423.7	475.0	70.0	548.6	40.00	50	15
GT28000420JHR01	28.00	3.60	16.0	423.7	477.0	70.0	550.6	40.00	50	15



DEEPTRIOMC™ CONVENTIONAL DRILLS: 20XD (METRIC)

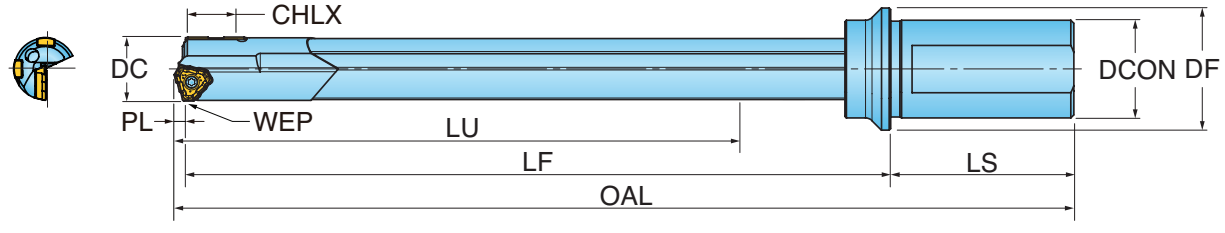

METRIC

Part Number	DC Cutting Dia.	PL Point Length	CHLX Cross-Hole Length Max.	LU Usable Length Max.	LF Functional Length	LS Shank Length	OAL Overall Length	DCON Connection Dia.	DF Flange Dia.	ULDR Usable Length Dia. Ratio
NEW GT0800168JER01	8.00	1.80	12.0	169.2	192.0	50.0	243.2	20.00	25	20
GT10000210JER01	10.00	1.80	16.0	211.8	237.0	50.0	288.8	20.00	25	20
GT10500220JER01	10.50	1.80	16.0	221.8	248.0	50.0	299.8	20.00	25	20
GT11000240JER01	11.00	1.80	16.0	241.8	269.0	50.0	320.8	20.00	25	20
GT11500240JER01	11.50	1.80	16.0	241.8	269.0	50.0	320.8	20.00	25	20

INCH

Part Number	DC Cutting Dia.	PL Point Length	CHLX Cross-Hole Length Max.	LU Usable Length Max.	LF Functional Length	LS Shank Length	OAL Overall Length	DCON Connection Dia.	DF Flange Dia.	ULDR Usable Length Dia. Ratio
NEW GT07940168N4R01	0.313	0.046	0.45	6.61	7.513	1.97	9.482	0.75	0.98	20
NEW GT08730180N4R01	0.344	0.046	0.45	7.09	8.025	1.97	9.994	0.75	0.98	20



DEEPTRIOMC™ CONVENTIONAL DRILLS: 25XD (INCH)

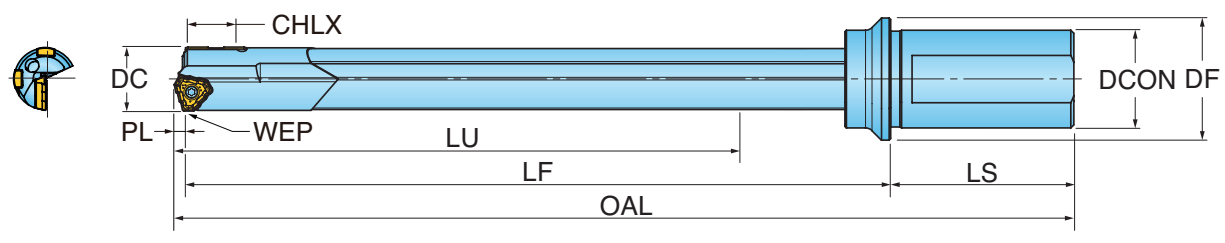

INCH

Part Number	DC Cutting Dia.	PL Point Length	CHLX Cross-Hole Length Max.	LU Usable Length Max.	LF Functional Length	LS Shank Length	OAL Overall Length	DCON Connection Dia.	DF Flange Dia.	ULDR Usable Length Dia. Ratio
NEW GT07940210N4R01	0.313	0.046	0.45	8.27	9.17	1.97	11.14	0.750	0.98	25
NEW GT08730225N4R01	0.344	0.046	0.45	8.86	9.80	1.97	11.77	0.750	0.98	25
NEW GT09530243N4R01	0.375	0.045	0.45	9.57	10.55	1.97	12.52	0.750	0.98	25
GT11110300N4R01	0.437	0.071	0.63	11.88	12.95	1.97	14.99	0.750	0.98	25
GT12700317N5R01	0.500	0.071	0.63	12.87	14.13	2.21	16.41	1.000	1.26	25
GT13490337N5R01	0.531	0.071	0.63	13.85	15.16	2.21	17.43	1.000	1.26	25
GT14270357N5R01	0.562	0.079	0.63	14.84	16.18	2.21	18.47	1.000	1.26	25
GT14680375N5R01	0.578	0.079	0.63	14.84	16.22	2.21	18.50	1.000	1.26	25
GT15060400N5R01	0.593	0.079	0.63	15.83	17.24	2.21	19.53	1.000	1.26	25
GT15880400N5R01	0.625	0.079	0.63	15.83	17.28	2.21	19.57	1.000	1.26	25
GT17450436N5R02	0.687	0.087	0.63	17.80	19.29	2.21	21.58	1.000	1.26	25
GT18240456N5R01	0.718	0.118	0.63	18.82	20.35	2.21	22.68	1.000	1.26	25
GT18640466N5R01	0.734	0.118	0.63	18.82	20.35	2.21	22.68	1.000	1.26	25
GT19050476N5R01	0.750	0.118	0.63	19.80	21.38	2.21	23.70	1.000	1.26	25
GT20620516N6R01	0.812	0.126	0.63	20.80	22.44	2.36	24.93	1.250	1.57	25
GT22230556N6R01	0.875	0.134	0.63	22.77	24.53	2.36	27.02	1.250	1.57	25
GT23800595N6R01	0.937	0.134	0.63	24.74	26.61	2.36	29.11	1.250	1.57	25
GT25400635N6R01	1.000	0.146	0.63	25.74	27.64	2.36	30.14	1.250	1.57	25
GT26970674N6R01	1.062	0.146	0.63	27.71	29.72	2.36	32.23	1.250	1.57	25
GT26970675N6R01	1.062	0.146	0.63	27.71	29.72	2.36	32.23	1.500	1.57	25
GT28580715N6R01	1.125	0.181	0.63	28.54	31.30	2.36	33.84	1.250	1.57	25
GT29360715N6R01	1.156	0.181	0.63	29.53	32.36	2.36	34.90	1.250	1.57	25
GT31750806N6R01	1.250	0.181	0.63	31.50	34.45	2.36	36.99	1.250	1.57	25



DEEPTRIOMC™ CONVENTIONAL DRILLS: 25XD (METRIC)

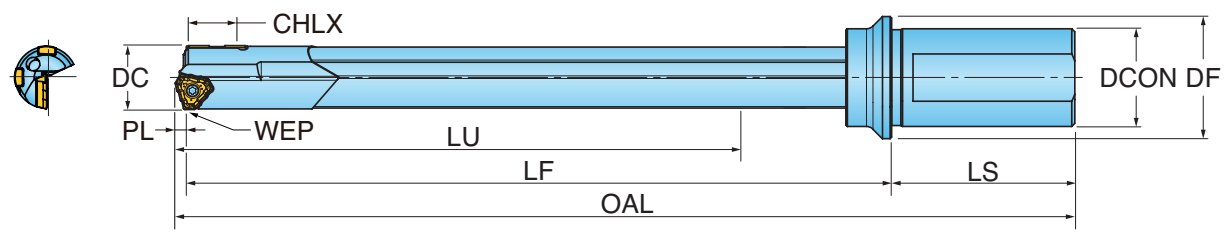

METRIC

NEW
NEW
NEW

Part Number	DC Cutting Dia.	PL Point Length	CHLX Cross-Hole Length Max.	LU Usable Length Max.	LF Functional Length	LS Shank Length	OAL Overall Length	DCON Connection Dia.	DF Flange Dia.	ULDR Usable Length Dia. Ratio
GT0800210JER01	8.00	1.20	12.0	211.2	234.0	50.0	285.2	20.00	25	25
GT0850218JER01	8.50	1.20	12.0	218.7	242.5	50.0	293.7	20.00	25	25
GT0900235JER01	9.00	1.10	12.0	236.1	261.0	50.0	312.1	20.00	25	25
GT10000263JER01	10.00	1.80	16.0	264.3	289.5	50.0	341.3	20.00	25	25
GT10500275JER01	10.50	1.80	16.0	276.8	303.0	50.0	354.8	20.00	25	25
GT11000300JER01	11.00	1.80	16.0	301.8	329.0	50.0	380.8	20.00	25	25
GT11500300JER01	11.50	1.80	16.0	301.8	329.0	50.0	380.8	20.00	25	25
GT12000327JER01	12.00	1.8	16.0	326.8	355.0	50.0	406.8	20.00	25	25
GT12500327JER01	12.50	1.8	16.0	326.8	356.0	50.0	407.8	20.00	25	25
GT13000352JFR01	13.00	1.8	16.0	351.8	385.0	56.0	442.8	25.00	32	25
GT13500352JFR01	13.50	1.8	16.0	351.8	385.0	56.0	442.8	25.00	32	25
GT14000375JFR01	14.00	2.0	16.0	377.0	411.0	56.0	469.0	25.00	32	25
GT14500375JFR01	14.50	2.0	16.0	377.0	412.0	56.0	470.0	25.00	32	25
GT15000400JFR01	15.00	2.0	16.0	402.0	438.0	56.0	496.0	25.00	32	25
GT16000400JFR02	16.00	2.2	16.0	427.2	464.0	56.0	522.2	25.00	32	25
GT16500413JFR02	16.50	2.2	16.0	427.2	464.0	56.0	522.2	25.00	32	25
GT17000425JFR02	17.00	2.2	16.0	452.2	490.0	56.0	548.2	25.00	32	25
GT17500445JFR02	17.50	2.2	16.0	452.2	490.0	56.0	548.2	25.00	32	25
GT18000450JFR02	18.00	2.2	16.0	477.2	517.0	56.0	575.2	25.00	32	25
GT18500463JFR01	18.50	3.0	16.0	478.0	517.0	56.0	576.0	25.00	32	25
GT19000475JFR01	19.00	3.0	16.0	503.0	543.0	56.0	602.0	25.00	32	25
GT19500488JFR01	19.50	3.0	16.0	503.0	543.0	56.0	602.0	25.00	32	25
GT20000500JGR01	20.00	3.0	16.0	528.0	570.0	60.0	633.0	32.00	40	25
GT21000525JGR01	21.00	3.2	16.0	553.2	596.0	60.0	659.2	32.00	40	25
GT22000550JGR01	22.00	3.4	16.0	578.4	623.0	60.0	686.4	32.00	40	25
GT23000575JGR01	23.00	3.4	16.0	603.4	649.0	60.0	712.4	32.00	40	25
GT24000600JGR01	24.00	3.4	16.0	628.4	676.0	60.0	739.4	32.00	40	25
GT25000625JGR01	25.00	3.4	16.0	653.4	702.0	60.0	765.4	32.00	40	25
GT26000650JHR01	26.00	3.7	16.0	678.7	729.0	70.0	802.7	40.00	50	25
GT27000675JHR01	27.00	3.7	16.0	703.7	755.0	70.0	828.7	40.00	50	25
GT28000700JHR01	28.00	3.7	16.0	703.7	757.0	70.0	830.7	40.00	50	25



DEEPTRIOMC™ CONVENTIONAL CROSS-HOLE DRILLS: 10XD (INCH)

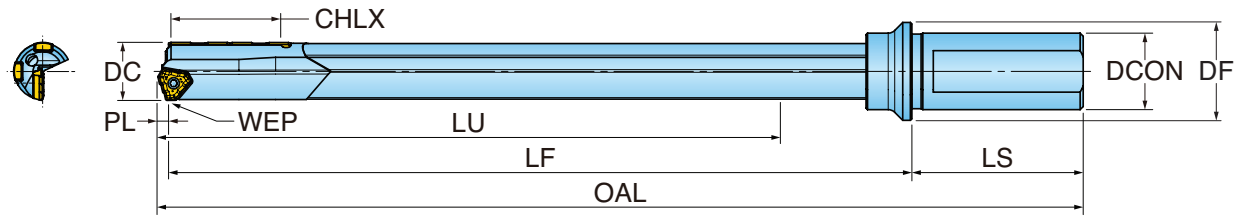

INCH

Part Number	DC Cutting Dia.	PL Point Length	CHLX Cross-Hole Length Max.	LU Usable Length Max.	LF Functional Length	LS Shank Length	OAL Overall Length	DCON Connection Dia.	DF Flange Dia.	ULDR Usable Length Dia. Ratio
GTADP14680147N5R01	0.578	0.079	1.26	5.91	7.36	2.21	9.65	1.000	1.26	10
GTADP15060151N5R01	0.593	0.079	1.26	6.30	7.79	2.21	10.08	1.000	1.26	10
GTADP18240182N5R01	0.718	0.118	1.26	7.48	9.13	2.21	11.46	1.000	1.26	10
GTADP18640186N5R01	0.734	0.118	1.26	7.48	9.13	2.21	11.46	1.000	1.26	10
GTADP23800238N6R01	0.937	0.134	1.26	9.84	11.85	2.36	14.35	1.250	1.57	10
GTADP29360293N6R01	1.156	0.181	1.26	11.81	14.65	2.36	17.19	1.250	1.57	10

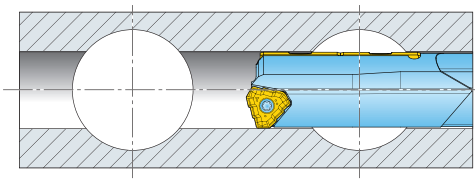

Extra long guide pads allow drilling through cross-holes up to 1.26" (32mm) dia.

An additional guide pad stabilizes the drill when the insert passes the cross-hole

For Cross-Hole Applications: Deep-Trio BTA, MC and GD with single row of guide pads can cross up to a .63" (16 mm) hole.

Deep-Trio MC and GD with a double row of guide pads can cross up to a 1.26" (32 mm) hole.



DEEPTRIOMC™ CONVENTIONAL CROSS-HOLE DRILLS: 15XD (INCH)

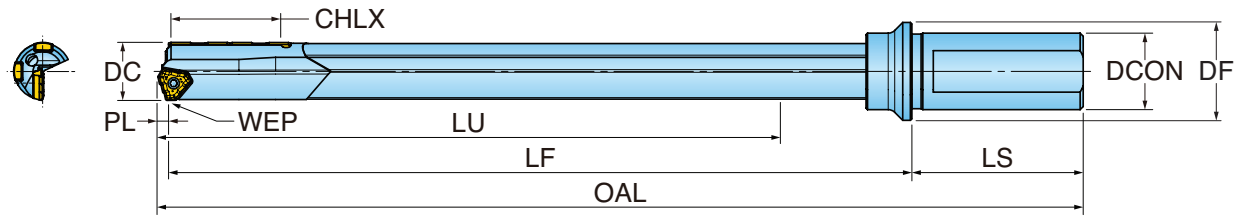

INCH

Part Number	DC Cutting Dia.	PL Point Length	CHLX Cross-Hole Length Max.	LU Usable Length Max.	LF Functional Length	LS Shank Length	OAL Overall Length	DCON Connection Dia.	DF Flange Dia.	ULDR Usable Length Dia. Ratio
NEW GTADP09530146N4R01	0.375	0.045	0.91	5.75	6.73	1.97	8.70	0.750	0.98	15
GTADP11110180N4R01	0.437	0.071	1.26	7.16	8.23	1.97	10.27	0.750	0.98	15
GTADP14680220N5R01	0.578	0.079	1.26	8.86	10.31	2.21	12.60	1.000	1.26	15
GTADP15060226N5R01	0.593	0.079	1.26	9.45	10.94	2.21	13.23	1.000	1.26	15
GTADP18240274N5R01	0.718	0.118	1.26	11.22	12.87	2.21	15.20	1.000	1.26	15
GTADP18640280N5R01	0.734	0.118	1.26	11.22	12.87	2.21	15.20	1.000	1.26	15
GTADP23800357N6R01	0.937	0.134	1.26	14.76	16.77	2.36	19.27	1.250	1.57	15
GTADP29360440N6R01	1.156	0.181	1.26	17.72	20.55	2.36	23.09	1.250	1.57	15

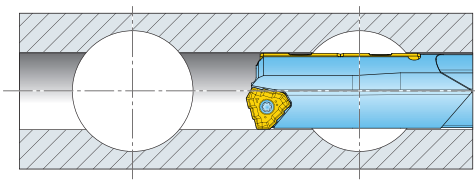

For Cross-Hole Applications:
 Deep-Trio BTA, MC and GD with single row of guide pads can cross up to a .63" (16 mm) hole.
 Deep-Trio MC and GD with a double row of guide pads can cross up to a 1.26" (32 mm) hole.



DEEPTRIOMC™ CONVENTIONAL CROSS-HOLE DRILLS: 20XD (INCH)

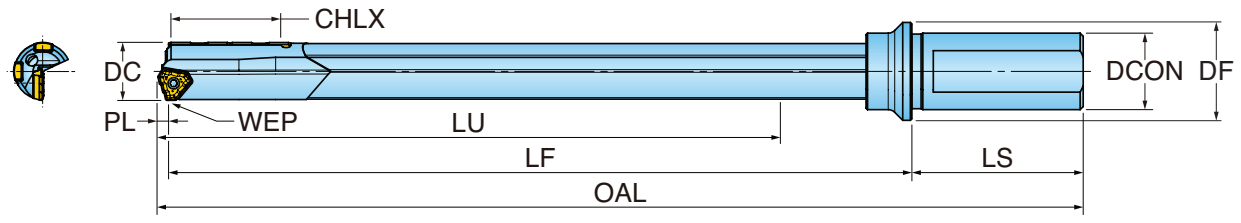

INCH

Part Number	DC Cutting Dia.	PL Point Length	CHLX Cross-Hole Length Max.	LU Usable Length Max.	LF Functional Length	LS Shank Length	OAL Overall Length	DCON Connection Dia.	DF Flange Dia.	ULDR Usable Length Dia. Ratio
NEW NEW GTADP07940168N4R01	0.313	0.046	0.91	6.61	7.51	1.97	9.48	0.750	0.98	20
GTADP08730180N4R01	0.344	0.046	0.91	7.09	8.03	1.97	9.99	0.750	0.98	20

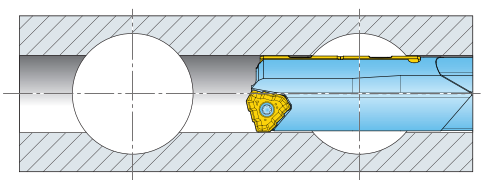

For Cross-Hole Applications:
 Deep-Trio BTA, MC and GD with single row of guide pads can cross up to a .63" (16 mm) hole.
 Deep-Trio MC and GD with a double row of guide pads can cross up to a 1.26" (32 mm) hole.



DEEPTRIOMC™ CONVENTIONAL CROSS-HOLE DRILLS: 25XD (INCH)

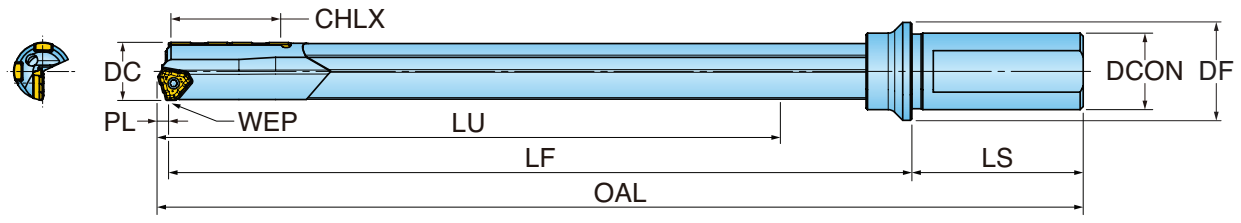

INCH

NEW
NEW
NEW

Part Number	DC Cutting Dia.	PL Point Length	CHLX Cross-Hole Length Max.	LU Usable Length Max.	LF Functional Length	LS Shank Length	OAL Overall Length	DCON Connection Dia.	DF Flange Dia.	ULDR Usable Length Dia. Ratio
GTADP07940210N4R01	0.313	0.046	0.91	8.27	9.167	1.97	11.136	0.750	0.98	25
GTADP08730225N4R01	0.344	0.046	0.91	8.86	9.797	1.97	11.766	0.750	0.98	25
GTADP09530243N4R01	0.375	0.045	0.91	9.57	10.546	1.97	12.515	0.750	0.98	25
GTADP11110300N4R01	0.437	0.071	1.26	11.88	12.95	1.97	14.99	0.750	0.98	25
GTADP14680367N5R01	0.578	0.079	1.26	14.84	16.22	2.21	18.50	1.000	1.26	25
GTADP15060377N5R01	0.593	0.079	1.26	15.83	17.24	2.21	19.53	1.000	1.26	25
GTADP18240456N5R01	0.718	0.118	1.26	18.82	20.35	2.21	22.68	1.000	1.26	25
GTADP18640466N5R01	0.734	0.118	1.26	18.82	20.35	2.21	22.68	1.000	1.26	25
GTADP23800507N6R01	0.937	0.134	1.26	21.27	23.15	2.36	25.65	1.250	1.57	21
GTADP23800595N6R01	0.937	0.134	1.26	24.74	26.61	2.36	29.11	1.250	1.57	25
GTADP29360734N6R01	1.156	0.102	1.26	28.90	31.55	2.36	34.09	1.250	1.57	25

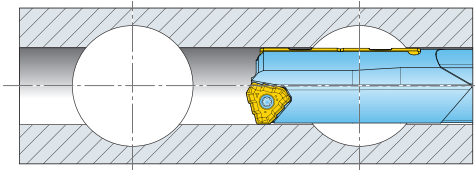

Extra long guide pads allow drilling through cross-holes up to 1.26" (32mm) dia.

An additional guide pad stabilizes the drill when the insert passes the cross-hole

For Cross-Hole Applications: Deep-Trio BTA, MC and GD with single row of guide pads can cross up to a .63" (16 mm) hole.

Deep-Trio MC and GD with a double row of guide pads can cross up to a 1.26" (32 mm) hole.

DEEPTRIO^{GD} DEEP TRIO GD GUNDRILLS - GUNDRILL DRIVER (INCH)

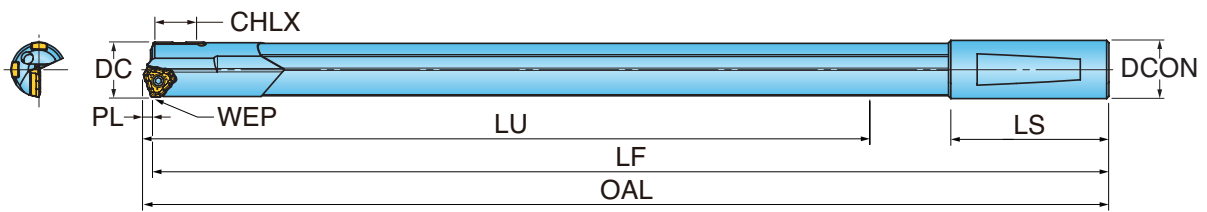

Deep-Trio Gundrills are made to order per application. Use the following guideline to determine the Description:

GT **XXXX** **YYYY** **ZZ** **RXX**
 Series Drill Dia. (mm) Drill Length (OAL) (mm) Driver Variation

Example:
 .75" diameter drill with 72" OAL and 1.00" driver = GT-1905-1828-58-RXX

Reference pages 15-18 for Insert and Guide Pad information.
 Reference page 11 for Driver information.

SEMI-STANDARD ITEMS

Part Number	DC Cutting Dia.	PL Point Length	CHLX Cross-Hole Length Max.	LU Usable Length Max.	LF Functional Length	LS Shank Length	OAL Overall Length	DCON Connection Dia.
GT-1270-1219-58-R01	0.500	0.071	0.630	43.78	48.00	2.21	48.07	1.000
GT-1270-1524-58-R01	0.500	0.071	0.630	55.78	60.00	2.21	60.07	1.000
GT-1348-1219-58-R01	0.531	0.071	0.630	43.66	48.00	2.21	48.07	1.000
GT-1348-1527-58-R01	0.531	0.071	0.630	55.66	60.00	2.21	60.07	1.000
GT-1745-1500-58-R01	0.687	0.086	0.630	55.40	59.05	2.21	59.14	1.000
GT-1824-1500-58-R01	0.718	0.118	0.630	55.35	59.05	2.21	59.17	1.000
GT-1864-1500-58-R01	0.734	0.118	0.630	55.81	59.05	2.21	59.17	1.000
GT-1905-1500-59-R01	0.750	0.118	0.630	55.35	59.05	2.76	59.17	1.250
GT-2062-1500-59-R01	0.812	0.118	0.630	55.24	59.05	2.76	59.18	1.250
GT-2223-1500-59-R01	0.875	0.134	0.630	55.13	59.05	2.76	59.19	1.250
GT-2380-1500-59-R01	0.937	0.134	0.630	55.02	59.05	2.76	59.19	1.250
GT-2540-1500-59-R01	1.000	0.146	0.630	54.98	59.05	2.76	59.20	1.250



DEEPTRIO^{GD} DEEP TRIO GD CROSS-HOLE GUNDRILLS - CYLINDRICAL DRIVER (INCH)

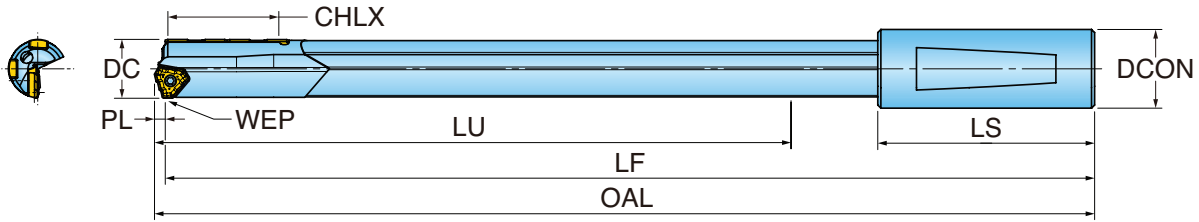

Deep-Trio Gundrills are made to order per application. Use the following guideline to determine the Description:

GTADP **XXXX** **YYYY** **ZZ** **RXX**
 Series Drill Dia. (mm) Drill Length (OAL) (mm) Driver Variation

Example:
 .75" diameter drill with 72" OAL and 1.00" driver = GTADP-1905-1828-58-RXX

Reference pages 15-18 for Insert and Guide Pad information.
 Reference page 11 for Driver information.

STANDARD ITEMS

NEW
NEW
NEW
NEW
NEW

Part Number	DC Cutting Dia.	PL Point Length	CHLX Cross-Hole Length Max.	LU Usable Length Max.	LF Functional Length	LS Shank Length	OAL Overall Length	DCON Connection Dia.
GTADP-0794-1219-S7-R01	0.313	0.047	0.906	45.49	47.99	2.03	48.04	0.750
GTADP-0873-1219-S7-R10	0.344	0.047	0.906	45.45	47.99	2.03	48.04	0.750
GTADP-0953-1219-S7-R01	0.375	0.043	0.906	45.41	47.99	2.03	48.04	0.750
GTADP-0794-1524-S7-R01	0.313	0.047	0.906	57.50	60.00	2.03	60.05	0.750
GTADP-0873-1524-S7-R01	0.344	0.047	0.906	57.46	60.00	2.03	60.05	0.750
GTADP-0953-1524-S7-R01	0.375	0.043	0.906	57.42	60.00	2.03	60.04	0.750
GTADP-1111-1524-S9-R01	0.437	0.071	1.26	56.58	60.00	2.76	60.07	1.25
GTADP-1427-1828-S9-R10	0.562	0.079	1.26	66.93	71.89	2.76	71.97	1.25
GTADP-1468-1524-S9-R01	0.578	0.079	1.26	55.00	60.20	2.76	60.28	1.25
GTADP-1468-1828-S9-R01	0.578	0.079	1.26	66.93	71.89	2.76	71.97	1.25
GTADP-1468-2286-S9-R01	0.578	0.079	1.26	84.72	89.92	2.76	90.00	1.25
GTADP-1506-1500-S9-R01	0.593	0.079	1.26	53.98	58.98	2.76	59.06	1.25
GTADP-1506-1828-S9-R01	0.593	0.079	1.26	66.89	71.89	2.76	71.97	1.25
GTADP-1824-1524-S9-R01	0.718	0.118	1.26	55.00	60.20	2.76	60.32	1.25
GTADP-1824-1828-S9-R01	0.718	0.118	1.26	66.65	71.65	2.76	71.77	1.25
GTADP-1824-2286-S9-R01	0.718	0.118	1.26	84.69	89.88	2.76	90.00	1.25
GTADP-1864-1500-S9-R01	0.734	0.118	1.26	53.70	58.94	2.76	59.06	1.25
GTADP-1864-1828-S9-R01	0.734	0.118	1.26	66.61	71.83	2.76	71.97	1.25
GTADP-2380-1500-S9-R01	0.937	0.126	1.26	52.76	58.93	2.76	59.06	1.25
GTADP-2380-1524-S9-R01	0.937	0.126	1.26	54.61	59.99	2.76	60.12	1.25
GTADP-2380-1828-S9-R01	0.937	0.126	1.26	65.67	71.84	2.76	71.97	1.25
GTADP-2380-2286-S9-R01	0.937	0.126	1.26	83.70	89.88	2.76	90.00	1.25
GTADP-2936-1828-S9-R01	1.156	0.102	1.26	66.52	71.97	2.76	92.07	1.25

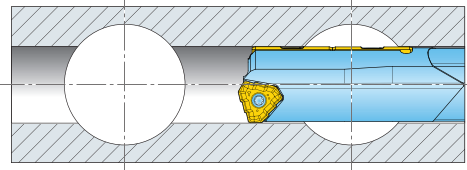

For Cross-Hole Applications:
 Deep-Trio BTA, MC and GD with single row of guide pads can cross up to a .63" (16 mm) hole.
 Deep-Trio MC and GD with a double row of guide pads can cross up to a 1.26" (32 mm) hole.



DEEPTRIO^{GD}™ STANDARD GUNDRILL DRIVERS

	Driver Type	Drawing	DCON	LS	Driver Code	Carbide Tipped Gun Drills	Solid Carbide Gun Drills
METRIC	Cylindrical DIN1835A DIN6535HA		10	40	05	•	•
			12	45	06	•	•
			16	48	08	•	•
			20	50	10	•	
			25	56	11	•	
	Weldon DIN1835B DIN6535HB		10	40	18	•	•
			12	45	19	•	•
			16	48	20	•	•
			20	50	22	•	•
			25	56	23	•	
	Whistle Notch DIN1835E		10	40	30	•	•
			12	45	31	•	•
			16	48	32	•	•
			20	50	34	•	•
			25	56	35	•	
	Whistle Notch DIN6535HE		10	40	40	•	•
			12	45	41	•	•
			16	48	42	•	•
			18	50	44	•	•
	Central clamping surface 15°		10	40	54	•	•
16			45	55	•		
25			70	57	•		
INCH	Central clamping surface 15°		.750	2.748	56	•	
			1.00	2.748	58	•	
	Central clamping tapered		.750	2.748	76	•	
	Frontal clamping surface 2°		.750	2.748	79	•	
			1.00	2.748	80	•	
	Cylindrical DIN1835A DIN6535HA		.500	1.781	94	•	
			.750	2.031	95	•	
			1.000	2.281	96	•	
			1.250	2.281	97	•	
Weldon DIN1835B DIN6535HB		.500	1.781	98	•		
		.750	2.031	99	•		
		1.000	2.281	100	•		
		1.250	2.281	101	•		

• Recommended design



DEEPTRIOBTA™ TBTA-DT DRILL HEADS **STS** Single Tube System **OUTER TWO/FOUR START THREAD**

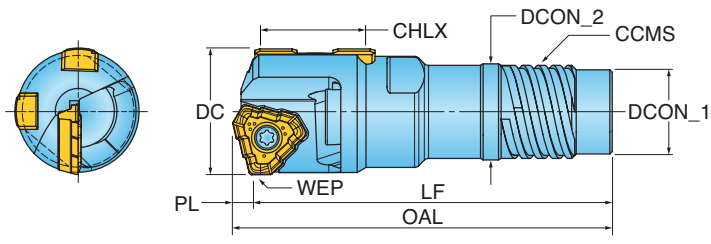

SINGLE TUBE SYSTEM - OUTER TWO START THREAD

Part Number	DC Cutting Dia.	PL Point Length	LF Functional Length	CHLX Cross-Hole Length Max.	OAL Overall Length	DCON1 Shank Dia.	DCON2 Shank Dia.	CCMS Connect. Code Machine Side	TUBE Part Number
TBTA-DTX.XXXSE2-12	0.551-0.575	0.079	2.24	0.71	2.32	0.362	0.417	BTA SE2-12	BTSI012
TBTA-DTX.XXXSE2-13	0.575-0.614	0.079	2.24	0.71	2.32	0.402	0.457	BTA SE2-13	BTSI013

SINGLE TUBE SYSTEM - OUTER FOUR START THREAD

Part Number	DC Cutting Dia.	PL Point Length	LF Functional Length	CHLX Cross-Hole Length Max.	OAL Overall Length	DCON1 Shank Dia.	DCON2 Shank Dia.	CCMS Connect. Code Machine Side	TUBE Part Number
TBTA-DTX.XXXSE4-14	0.614-0.630	0.079	2.24	0.71	2.32	0.425	0.496	BTA SE4-14	BTSI014
TBTA-DTX.XXXSE4-14	0.630-0.657	0.118	2.17	0.79	2.28	0.425	0.496	BTA SE4-14	BTSI014
TBTA-DTX.XXXSE4-15	0.658-0.697	0.118	2.17	0.79	2.28	0.465	0.535	BTA SE4-15	BTSI015
TBTA-DTX.XXXSE4-16	0.697-0.709	0.118	2.20	0.79	2.32	0.492	0.571	BTA SE4-16	BTSI016
TBTA-DTX.XXXSE4-16	0.709-0.744	0.118	2.20	0.79	2.32	0.492	0.571	BTA SE4-16	BTSI016
TBTA-DTX.XXXSE4-17	0.744-0.787	0.118	2.20	0.79	2.32	0.531	0.610	BTA SE4-17	BTSI017
TBTA-DTX.XXXSE4-18	0.788-0.827	0.079	2.36	0.79	2.44	0.551	0.630	BTA SE4-18	BTSI018
TBTA-DTX.XXXSE4-18	0.827-0.858	0.079	2.36	0.79	2.44	0.551	0.630	BTA SE4-18	BTSI018
TBTA-DTX.XXXSE4-20	0.859-0.866	0.098	2.50	0.79	2.60	0.630	0.709	BTA SE4-20	BTSI020
TBTA-DTX.XXXSE4-20	0.866-0.949	0.138	2.58	0.79	2.72	0.630	0.709	BTA SE4-20	BTSI020
TBTA-DTX.XXXSE4-22	0.949-0.984	0.138	2.58	0.79	2.72	0.689	0.768	BTA SE4-22	BTSI022
TBTA-DTX.XXXSE4-22	0.985-1.039	0.138	2.58	0.79	2.72	0.689	0.768	BTA SE4-22	BTSI022
TBTA-DTX.XXXSE4-24	1.040-1.102	0.138	2.58	0.79	2.72	0.748	0.827	BTA SE4-24	BTSI024
TBTA-DTX.XXXSE4-24	1.103-1.130	0.181	2.76	0.79	2.94	0.748	0.827	BTA SE4-24	BTSI024
TBTA-DTX.XXXSE4-26	1.130-1.181	0.181	2.95	0.79	3.13	0.827	0.925	BTA SE4-26	BTSI026
TBTA-DTX.XXXSE4-26	1.181-1.220	0.181	2.95	0.79	3.13	0.827	0.925	BTA SE4-26	BTSI026
TBTA-DTX.XXXSE4-28	1.221-1.260	0.181	2.95	0.79	3.13	0.906	1.004	BTA SE4-28	BTSI028
TBTA-DTX.XXXSE4-28	1.260-1.311	0.213	2.93	0.79	3.15	0.906	1.004	BTA SE4-28	BTSI028
TBTA-DTX.XXXSE4-30	1.311-1.425	0.213	3.13	0.79	3.34	1.004	1.102	BTA SE4-30	BTSI030
TBTA-DTX.XXXSE4-33	1.426-1.535	0.213	3.52	0.79	3.74	1.063	1.181	BTA SE4-33	BTSI033
TBTA-DTX.XXXSE4-33	1.536-1.559	0.213	3.52	0.98	3.74	1.063	1.181	BTA SE4-33	BTSI033
TBTA-DTX.XXXSE4-36	1.559-1.575	0.213	3.72	0.98	3.93	1.181	1.299	BTA SE4-36	BTSI036



DEEPTRIO^{BTA}™ TBTA-DT DRILL HEADS **STS** Single Tube System **OUTER FOUR START THREAD**

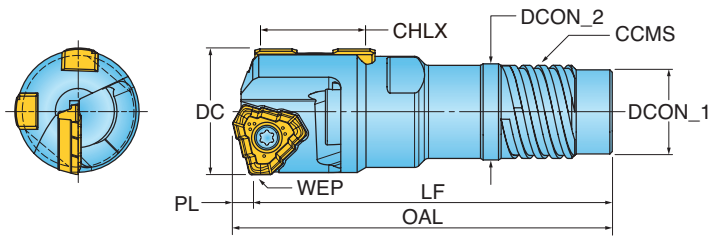

SINGLE TUBE SYSTEM - OUTER FOUR START THREAD (STANDARD ITEMS)

Part Number	DC Cutting Dia.	PL Point Length	LF Functional Length	CHLX Cross-Hole Length Max.	OAL Overall Length	DCON1 Shank Dia.	DCON2 Shank Dia.	CCMS Connect. Code Machine Side	TUBE Part Number
TBTA-DT.625SE4-14	0.625	0.079	2.244	0.709	2.323	0.425	0.496	BTA SE4-14	BTSI014
TBTA-DT.718SE4-16	0.718	0.118	2.205	0.629	2.323	0.492	0.571	BTA SE4-16	BTSI015
TBTA-DT.734SE4-16	0.734	0.118	2.205	0.629	2.323	0.492	0.571	BTA SE4-16	BTSI016
TBTA-DT.750SE4-17	0.750	0.118	2.205	0.629	2.323	0.531	0.610	BTA SE4-17	BTSI017
TBTA-DT.812SE4-18	0.812	0.126	2.362	0.629	2.488	0.531	0.630	BTA SE4-18	BTSI018
TBTA-DT.875SE4-20	0.875	0.134	2.579	0.629	2.713	0.630	0.709	BTA SE4-20	BTSI020
TBTA-DT.879SE4-20	0.879	0.134	2.579	0.629	2.713	0.630	0.709	BTA SE4-20	BTSI020
TBTA-DT.880SE4-20	0.880	0.134	2.579	0.629	2.713	0.630	0.709	BTA SE4-20	BTSI020
TBTA-DT.889SE4-20	0.889	0.134	2.579	0.629	2.713	0.630	0.709	BTA SE4-20	BTSI020
TBTA-DT.920SE4-20	0.920	0.134	2.579	0.629	2.713	0.630	0.709	BTA SE4-20	BTSI020
TBTA-DT.937SE4-20	0.937	0.134	2.579	0.629	2.713	0.630	0.709	BTA SE4-20	BTSI020
TBTA-DT.965SE4-22	0.965	0.142	2.657	0.629	2.799	0.689	0.768	BTA SE4-22	BTSI022
TBTA-DT.969SE4-22	0.969	0.142	2.657	0.629	2.799	0.689	0.768	BTA SE4-22	BTSI022
TBTA-DT.977SE4-22	0.977	0.142	2.657	0.629	2.799	0.689	0.768	BTA SE4-22	BTSI022
TBTA-DT1.000SE4-22	1.000	0.142	2.657	0.629	2.799	0.689	0.768	BTA SE4-22	BTSI022
TBTA-DT1.031SE4-22	1.031	0.142	2.657	0.629	2.799	0.689	0.768	BTA SE4-22	BTSI022
TBTA-DT1.102SE4-24	1.102	0.142	2.657	0.629	2.799	0.748	0.827	BTA SE4-24	BTSI024
TBTA-DT1.250SE4-28	1.250	0.214	2.933	0.629	2.950	0.906	1.004	BTA SE4-28	BTSI028
TBTA-DT1.299SE4-28	1.299	0.214	2.933	0.629	2.950	0.906	1.004	BTA SE4-28	BTSI028
TBTA-DT1.375SE4-30	1.375	0.214	3.130	0.629	3.344	1.004	1.102	BTA SE4-30	BTSI030
TBTA-DT1.378SE4-30	1.378	0.214	3.130	0.629	3.344	1.004	1.102	BTA SE4-30	BTSI030
TBTA-DT1.456SE4-33	1.456	0.214	3.524	0.629	3.737	1.063	1.181	BTA SE4-33	BTSI033
TBTA-DT1.496SE4-33	1.496	0.214	3.524	0.629	3.737	1.063	1.181	BTA SE4-33	BTSI033
TBTA-DT1.500SE4-33	1.500	0.214	3.524	0.629	3.737	1.063	1.181	BTA SE4-33	BTSI033
TBTA-DT1.575SE4-36	1.575	0.214	3.720	0.629	3.934	1.181	1.299	BTA SE4-36	BTSI036



DEEPTRIO^{BTA}™ TBTA-DT DRILL HEADS **STS** Single Tube System **INNER SINGLE START THREAD**

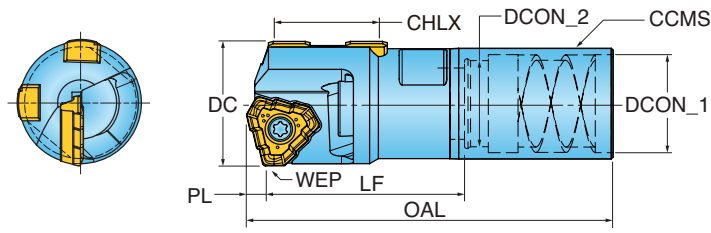

SINGLE TUBE SYSTEM - INNER SINGLE START THREAD

Part Number	DC Cutting Dia.	PL Point Length	LF Functional Length	CHLX Cross-Hole Length Max.	OAL Overall Length	DCON1 Shank Dia.	DCON2 Shank Dia.	CCMS Connect. Code Machine Side	TUBE Part Number
TBTA-DTX.XXXSI1-12A	0.571-0.591	0.075	2.24	0.71	2.32	0.453	0.390	BTA SI1-12A	BTSE012A
TBTA-DTX.XXXSI1-12B	0.591-0.610	0.075	2.24	0.71	2.32	0.465	0.402	BTA SI1-12B	BTSE012B
TBTA-DTX.XXXSI1-13A	0.611-0.630	0.075	2.24	0.71	2.32	0.488	0.425	BTA SI1-13A	BTSE13A
TBTA-DTX.XXXSI1-13A	0.630-0.630	0.118	2.13	0.79	2.21	0.488	0.425	BTA SI1-13A	BTSE13A
TBTA-DTX.XXXSI1-13B	0.630-0.650	0.118	2.13	0.79	2.21	0.500	0.437	BTA SI1-13B	BTSE13B
TBTA-DTX.XXXSI1-14A	0.650-0.679	0.118	2.13	0.79	2.21	0.528	0.465	BTA SI1-14A	BTSE14A
TBTA-DTX.XXXSI1-14B	0.680-0.709	0.118	2.13	0.79	2.21	0.539	0.476	BTA SI1-14B	BTSE14B
TBTA-DTX.XXXSI1-15	0.709-0.748	0.118	2.13	0.79	2.24	0.567	0.504	BTA SI1-15	BTSE15
TBTA-DTX.XXXSI1-16.5	0.748-0.787	0.118	2.13	0.79	2.24	0.606	0.543	BTA SI1-16.5	BTSE16.5
TBTA-DTX.XXXSI1-18	0.787-0.787	0.138	2.26	0.79	2.38	0.650	0.571	BTA SI1-18	BTSE18
TBTA-DTX.XXXSI1-18	0.788-0.827	0.098	2.30	0.79	2.43	0.650	0.571	BTA SI1-18	BTSE18
TBTA-DTX.XXXSI1-18	0.827-0.866	0.098	2.30	0.79	2.43	0.650	0.571	BTA SI1-18	BTSE18
TBTA-DTX.XXXSI1-20	0.866-0.984	0.138	2.38	0.79	2.52	0.748	0.630	BTA SI1-20	BTSE20
TBTA-DTX.XXXSI1-22	0.984-0.984	0.138	2.38	0.79	2.52	0.787	0.669	BTA SI1-22	BTSE22
TBTA-DTX.XXXSI1-22	0.985-1.063	0.157	2.56	0.79	2.70	0.787	0.669	BTA SI1-22	BTSE22
TBTA-DTX.XXXSI1-24	1.063-1.102	0.157	2.56	0.79	2.70	0.866	0.748	BTA SI1-24	BTSE24
TBTA-DTX.XXXSI1-24	1.103-1.181	0.181	2.76	0.79	2.94	0.866	0.748	BTA SI1-24	BTSE24
TBTA-DTX.XXXSI1-26	1.181-1.259	0.181	2.95	0.79	3.13	0.945	0.827	BTA SI1-26	BTSE26
TBTA-DTX.XXXSI1-28	1.260-1.260	0.181	2.95	0.79	3.13	1.024	0.906	BTA SI1-28	BTSE28
TBTA-DTX.XXXSI1-28	1.260-1.338	0.213	2.95	0.79	3.17	1.024	0.906	BTA SI1-28	BTSE28
TBTA-DTX.XXXSI1-30	1.339-1.456	0.213	3.52	0.79	3.74	1.063	0.945	BTA SI1-30	BTSE30
TBTA-DTX.XXXSI1-33	1.457-1.535	0.213	3.72	0.79	3.93	1.181	1.063	BTA SI1-33	BTSE33
TBTA-DTX.XXXSI1-33	1.536-1.574	0.213	3.72	0.98	3.93	1.181	1.063	BTA SI1-33	BTSE33
TBTA-DTX.XXXSI1-36	1.575-1.575	0.213	3.92	0.98	4.13	1.299	1.181	BTA SI1-36	BTSE36

SINGLE TUBE SYSTEM - INNER SINGLE START THREAD (STANDARD ITEMS)

Part Number	DC Cutting Dia.	PL Point Length	LF Functional Length	CHLX Cross-Hole Length Max.	OAL Overall Length	DCON1 Shank Dia.	DCON2 Shank Dia.	CCMS Connect. Code Machine Side	TUBE Part Number
TBTA-DT.649SI1-13B	0.649	0.118	2.13	0.79	2.21	0.500	0.437	BTA SI1-13B	BTSE13B
TBTA-DT.708SI1-14B	0.708	0.118	2.13	0.79	2.21	0.539	0.476	BTA SI1-14B	BTSE14B
TBTA-DT.807SI1-18	0.807	0.098	2.30	0.79	2.43	0.650	0.571	BTA SI1-18	BTSE18
TBTA-DT.866SI1-18	0.866	0.098	2.30	0.79	2.43	0.650	0.571	BTA SI1-18	BTSE18
TBTA-DT.944SI1-20	0.944	0.138	2.38	0.79	2.52	0.748	0.630	BTA SI1-20	BTSE20
TBTA-DT.988SI1-22	0.988	0.157	2.56	0.79	2.70	0.787	0.669	BTA SI1-22	BTSE22
TBTA-DT1.023SI1-22	1.023	0.157	2.56	0.79	2.70	0.787	0.669	BTA SI1-22	BTSE22
TBTA-DT1.102SI1-24	1.102	0.157	2.56	0.79	2.70	0.866	0.748	BTA SI1-24	BTSE24



DEEPTRIO^{BTA}™ TBTA-DT DRILL HEADS **DTS** **OUTER FOUR START THREAD**
Double Tube System

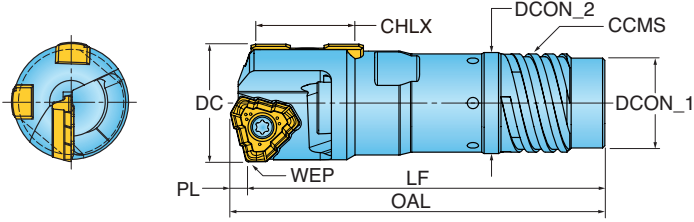

DOUBLE TUBE SYSTEM - OUTER FOUR START THREAD

Part Number	DC Cutting Dia.	PL Point Length	LF Functional Length	CHLX Cross-Hole Length Max.	OAL Overall Length	DCON1 Shank Dia.	DCON2 Shank Dia.	CCMS Connect. Code Machine Side	TUBE Part No. (Outer)	TUBE Part No. (Inner)
TBTA-DTX.XXXDE4-18	0.724-0.787	0.118	2.32	0.79	2.44	0.551	0.630	BTA DE4-18	BTDO018	BTDI012
TBTA-DTX.XXXDE4-19.5	0.788-0.827	0.126	2.50	0.79	2.63	0.630	0.709	BTA DE4-19.5	BTDO019.5	BTDI014
TBTA-DTX.XXXDE4-19.5	0.827-0.858	0.126	2.50	0.79	2.63	0.630	0.709	BTA DE4-19.5	BTDO019.5	BTDI014
TBTA-DTX.XXXDE4-21.5	0.859-0.866	0.126	2.50	0.79	2.63	0.630	0.768	BTA DE4-21.5	BTDO021.5	BTDI015
TBTA-DTX.XXXDE4-21.5	0.866-0.949	0.134	2.58	0.79	2.71	0.630	0.768	BTA DE4-21.5	BTDO021.5	BTDI015
TBTA-DTX.XXXDE4-23.5	0.949-0.984	0.134	2.58	0.79	2.71	0.630	0.827	BTA DE4-23.5	BTDO023.5	BTDI016
TBTA-DTX.XXXDE4-23.5	0.985-1.039	0.142	2.66	0.79	2.80	0.630	0.827	BTA DE4-23.5	BTDO023.5	BTDI016
TBTA-DTX.XXXDE4-26	1.040-1.102	0.142	2.78	0.79	2.92	0.630	0.925	BTA DE4-26	BTDO026	BTDI018
TBTA-DTX.XXXDE4-26	1.103-1.130	0.181	2.95	0.79	3.13	0.630	0.925	BTA DE4-26	BTDO026	BTDI018
TBTA-DTX.XXXDE4-28	1.130-1.181	0.181	2.95	0.79	3.13	0.630	1.004	BTA DE4-28	BTDO028	BTDI020
TBTA-DTX.XXXDE4-28	1.181-1.220	0.181	2.95	0.79	3.13	0.630	1.004	BTA DE4-28	BTDO028	BTDI020
TBTA-DTX.XXXDE4-30.5	1.221-1.260	0.181	2.95	0.79	3.33	0.630	1.102	BTA DE4-30.5	BTDO030.5	BTDI022
TBTA-DTX.XXXDE4-30.5	1.260-1.311	0.213	3.15	0.79	3.36	0.630	1.102	BTA DE4-30.5	BTDO030.5	BTDI022
TBTA-DTX.XXXDE4-33	1.311-1.425	0.213	3.52	0.79	3.34	0.630	1.181	BTA DE4-33	BTDO033	BTDI024
TBTA-DTX.XXXDE4-35.5	1.426-1.535	0.213	3.72	0.79	3.93	0.630	1.299	BTA DE4-35.5	BTDO035.5	BTDI026
TBTA-DTX.XXXDE4-35.5	1.536-1.559	0.213	3.72	0.79	3.93	0.630	1.299	BTA DE4-35.5	BTDO035.5	BTDI026
TBTA-DTX.XXXDE4-39	1.559-1.575	0.213	3.92	0.79	4.13	0.630	1.417	BTA DE4-39	BTDO039	BTDI029

DOUBLE TUBE SYSTEM - OUTER FOUR START THREAD (STANDARD ITEMS)

Part Number	DC Cutting Dia.	PL Point Length	LF Functional Length	CHLX Cross-Hole Length Max.	OAL Overall Length	DCON1 Shank Dia.	DCON2 Shank Dia.	CCMS Connect. Code Machine Side	TUBE Part No. (Outer)	TUBE Part No. (Inner)
TBTA-DT.750DE4-18	0.750	0.118	2.402	0.629	2.193	0.551	0.630	BTA DE4-18	BTDO018	BTDI012
TBTA-DT.812DE4-19.5	0.812	0.126	2.50	0.79	2.63	0.630	0.709	BTA DE4-19.5	BTDO019.5	BTDI014
TBTA-DT.875DE4-21.5	0.875	0.134	2.58	0.79	2.71	0.630	0.768	BTA DE4-21.5	BTDO021.5	BTDI015
TBTA-DT.937DE4-21.5	0.937	0.134	2.58	0.79	2.71	0.630	0.768	BTA DE4-21.5	BTDO021.5	BTDI015
TBTA-DT1.000DE4-23.5	1.000	0.142	2.657	0.629	2.232	0.748	0.837	BTA DE4-23.5	BTDO023.5	BTDI016
TBTA-DT1.062DE4-26	1.062	0.142	2.78	0.79	2.92	0.630	0.925	BTA DE4-26	BTDO026	BTDI018
TBTA-DT1.102DE4-26	1.102	0.142	2.78	0.79	2.92	0.630	0.925	BTA DE4-26	BTDO026	BTDI018



DEEPTRIO™ ZPHT...-DT / ...-DT-P INSERTS

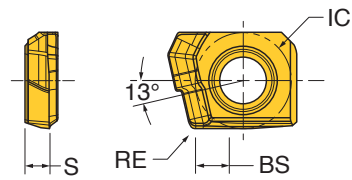

NEW
NEW

Drill Diameter - inch (mm)	Insert Number	Dims (inch)			Grades		
		IC Inscribed Circle	S Thickness	RE Radius	IN2005	IN2055	IN05S
.313-.354" (7.94-8.99 mm)	ZPHT040104R-DT	0.189	0.049	0.016	•		
.354-.393" (9.00-9.99 mm)	ZPHT050104R-DT	0.209	0.053	0.016	•		
.394-.471" (10.00-11.99 mm)	ZPHT060204R-DT	0.236	0.059	0.016		•	
.394-.471" (10.00-11.99 mm)	ZPHT060204R-DT-P	0.236	0.059	0.016			•

• = Stocked Items

DEEPTRIO™ LPHT...-DT / ...-DT-P INSERTS

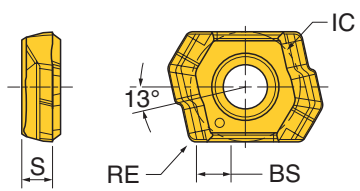

Drill Diameter - inch (mm)	Insert Number	Dims (inch)			Grades		
		IC Inscribed Circle	S Thickness	RE Radius	IN2005	IN2055	IN05S
.472-.550" (12.00-13.99 mm)	LPHT060204R-DT	0.278	0.078	0.016	•	•	
.472-.550" (12.00-13.99 mm)	LPHT060204R-DT-P	0.278	0.078	0.016			•

*IN2005 to be phased out as stock is depleted.

• = Stocked Items



DEEPTRIO™ TPHT...-DT INSERTS



TPHT07...-DT - TPHT08...-DT

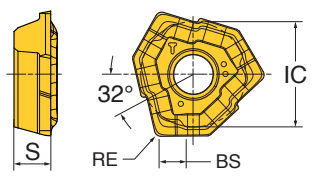

TPHT09...-DT - TPHT13...-DT

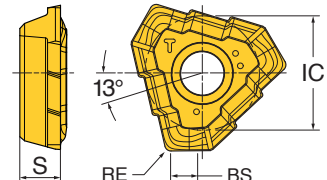

Drill Diameter - inch (mm)	Insert Number	Dims (inch)			Grades	
		IC Inscribed Circle	S Thickness	RE Radius	IN2005*	IN2055
.551-.629" (14.00-15.99 mm)	TPHT070304R-DT	0.302	0.090	0.016	•	•
.630-.708" (16.00-18.00 mm)	TPHT080304R-DT	0.336	0.090	0.020	•	•
.709-.787" (18.01-20.00 mm)	TPHT090305R-DT	0.328	0.118	0.020	•	•
.788-.865" (20.01-21.99 mm)	TPHT100305R-DT	0.363	0.130	0.020	•	•
.866-.984" (22.00-25.00 mm)	TPHT110405R-DT	0.409	0.150	0.020	•	•
.985-1.102" (25.01-28.00 mm)	TPHT120405R-DT	0.456	0.169	0.020	•	•
1.103-1.260" (28.01-32.00 mm)	TPHT130408R-DT	0.506	0.187	0.031	•	
1.261-1.575" (32.0-40.00 mm)	TPHT140510R-DT	0.663	0.207	0.039	•	

*IN2005 to be phased out as stock is depleted.

• = Stocked Items

DEEPTRIO™ TPHT...-DT-P INSERTS



TPHT07...-DT-P - TPHT08...-DT-P

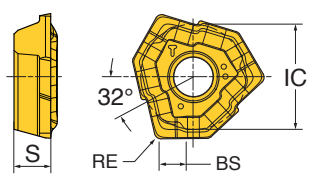

TPHT09...-DT-P - TPHT13...-DT-P

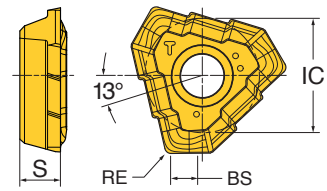

Drill Diameter - inch (mm)	Insert Number	Dims (inch)			Grades
		IC Inscribed Circle	S Thickness	RE Radius	IN055
.551-.629" (14.00-15.99 mm)	TPHT070304R-DT-P	0.302	0.090	0.016	•
.630-.708" (16.00-18.00 mm)	TPHT080304R-DT-P	0.336	0.090	0.020	•
.709-.787" (18.01-20.00 mm)	TPHT090305R-DT-P	0.328	0.118	0.020	•
.788-.865" (20.01-21.99 mm)	TPHT100305R-DT-P	0.363	0.130	0.020	•
.866-.984" (22.00-25.00 mm)	TPHT110405R-DT-P	0.409	0.150	0.020	•
.985-1.102" (25.01-28.00 mm)	TPHT120405R-DT-P	0.456	0.169	0.020	•
1.103-1.260" (28.01-32.00 mm)	TPHT130408R-DT-P	0.506	0.187	0.031	•
1.261-1.575" (32.01-40.00 mm)	TPHT140510R-DT-P	0.663	0.207	0.039	•

• = Stocked Items



DEEPTRIO™ TPHT...-ML INSERTS



TPHT07...-DT - TPHT08...-DT

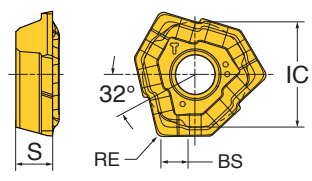

TPHT09...-DT - TPHT13...-DT

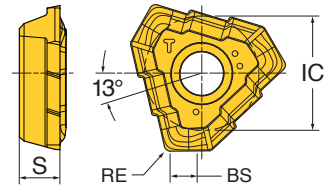

Drill Diameter - inch (mm)	Insert Number	Dims (inch)			Grades	
		IC Inscribed Circle	S Thickness	RE Radius	IN2005	IN2055
.551-.629" (14.00-15.99 mm)	TPHT070304R-ML	0.302	0.090	0.016	•	
.630-.708" (16.00-18.00 mm)	TPHT080304R-ML	0.336	0.090	0.020	•	
.709-.787" (18.01-20.00 mm)	TPHT090305R-ML	0.328	0.118	0.020	•	
.788-.865" (20.01-21.99 mm)	TPHT100305R-ML	0.363	0.130	0.020	•	
.866-.984" (22.00-25.00 mm)	TPHT110405R-ML	0.409	0.150	0.020	•	
.985-1.102" (25.01-28.00 mm)	TPHT120405R-ML	0.456	0.169	0.020	•	
1.103-1.260" (28.01-32.00 mm)	TPHT130408R-ML	0.506	0.187	0.031	•	

• = Stocked Items

DEEPTRIO™ TPHT INSERT FEATURES

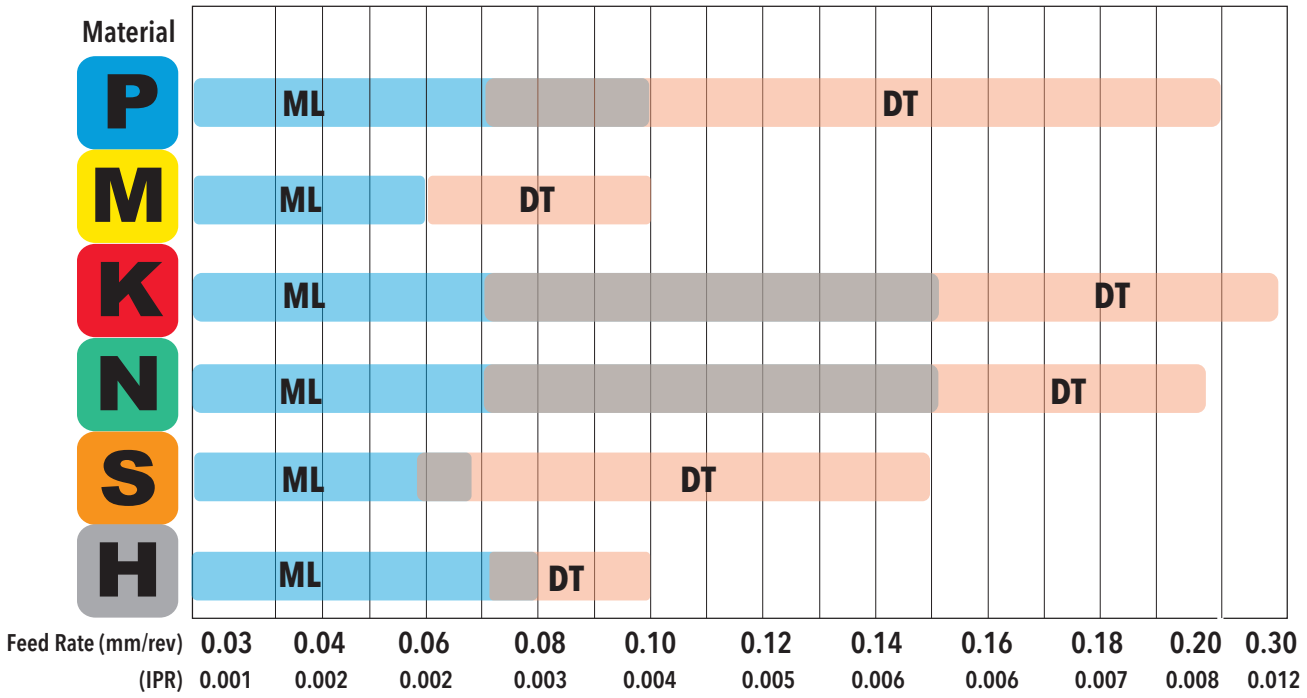
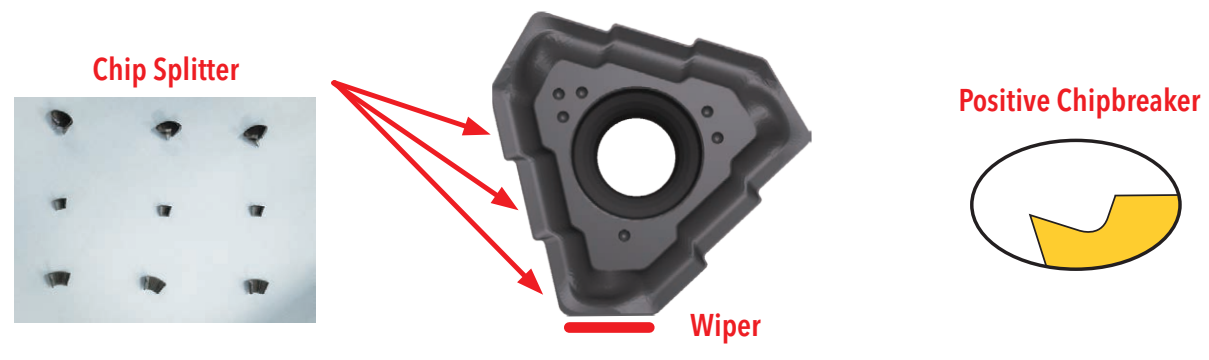



DEEPTRIO™ GUIDE PADS - MC/GD

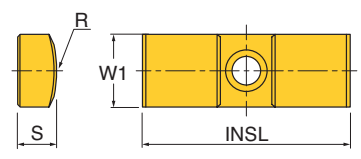

GRADE APPLICATION

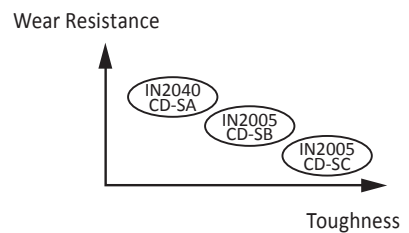

Drill Diameter - inch (mm)	Guide Pad Size	Dims (inch)				Grades		
		W1	S	INSL	R	IN2040 (CD-SA)	IN2005 (CD-SB)	IN2030 (CD-SC)
.313-.334" (7.94-8.48 mm)	PAD-GP04-12-045	0.154	0.063	0.472	0.138			
.335-.393" (8.49-9.99 mm)	PAD-GP03-12-040	0.154	0.063	0.472	0.157			
.394-.432" (10.00-10.99 mm)	PAD-GP04-016-045	0.157	0.071	0.63	0.177	•	•	•
.434-.472" (11.00-11.99 mm)	PAD-GP04-016-050	0.157	0.071	0.63	0.197	•	•	•
.472-.550" (12.00-13.99 mm)	PAD-GP04-016-055	0.157	0.078	0.629	0.216	•	•	•
.551-.629" (14.00-15.99 mm)	PAD-GP05-018-060	0.197	0.098	0.709	0.236	•	•	•
.630-.708" (16.00-18.00 mm)	PAD-GP05-018-075	0.197	0.098	0.709	0.295	•	•	•
.709-.826" (18.01-20.99 mm)	PAD-GP06-020-085	0.236	0.118	0.787	0.346	•	•	•
.827-.865" (21.00-21.99 mm)	PAD-GP06-020-100	0.236	0.118	0.787	0.394	•	•	•
.866-1.180" (22.00-29.99 mm)	PAD-GP06-020-120	0.236	0.118	0.787	0.472	•	•	•
1.181-1.535" (30.00-38.99 mm)	PAD-GP07-020-120	0.276	0.138	0.787	0.472	•	•	•
1.536-1.575" (39.00-40.00 mm)	PAD-GP08-025-155	0.315	0.177	0.984	0.610	•	•	•

• = Stocked Items

NEW
NEW

DEEPTRIO™ GUIDE PADS - BTA

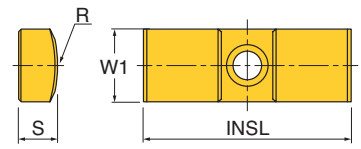

GRADE APPLICATION

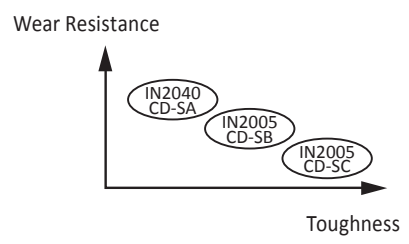

Drill Diameter - inch (mm)	Guide Pad Size	Dims (inch)				Grades		
		W1	S	INSL	R	IN2040 (CD-SA)	IN2005 (CD-SB)	IN2030 (CD-SC)
.551-.629" (14.00-15.99 mm)	PAD-GP05-018-060	0.197	0.098	0.709	0.236	•	•	•
.630-.709" (16.00-18.00 mm)	PAD-GP06-020-075	0.236	0.098	0.709	0.295	•	•	•
.710-.858" (18.01-21.79 mm)	PAD-GP06-020-085	0.236	0.118	0.787	0.346	•	•	•
.859-1.039" (21.80-26.39 mm)	PAD-GP06-020-100	0.236	0.118	0.787	0.394	•	•	•
1.040-1.180" (26.40-29.99 mm)	PAD-GP06-020-120	0.236	0.118	0.787	0.472	•	•	•
1.181-1.260" (30.00-32.00 mm)	PAD-GP07-020-120	0.276	0.138	0.787	0.472	•	•	•

• = Stocked Items



DEEPTRIO™ PARTS LIST - BTA

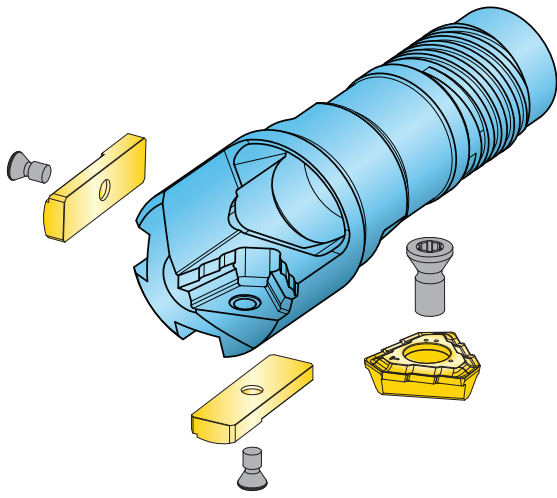

Components		Drill Diameter (inch)				
		.551-.629	.630-.708	.709-.787	.788-.866	.867-.984
Insert	Part No.	TPHT070304R	TPHT080305R	TPHT090305R	TPHT100305R	TPHT110405R
	Screw	SR14-560/S	SR14-560/S	SR14-560/S	SR34-506	SR14-571/S
	Wrench	T-8F	T-8F	T-8F	T-9F	T-9F
Guide Pads	Part No.	PAD-GP05-018-060	PAD-GP05-018-075	PAD-GP06-020-085	PAD-GP06-020-085	PAD-GP06-020-100
	Screw	SR34-508	SR34-508	SR34-508	SR34-508	SR34-508
	Wrench	T-7F	T-7F	T-7F	T-7F	T-7F

Components		Drill Diameter (inch)				
		.985-1.102	1.103-1.180	1.181-1.260	1.261-1.535	1.536-1.575
Insert	Part No.	TPHT120405R	TPHT130408R	TPHT130408R	TPHT140510R	TPHT140510R
	Screw	SR14-506	SR16-212/L10	SR16-212/L10	SR16-212/L10	SR16-212/L10
	Wrench	T-15F	T-20/5	T-20/5	T-20/5	T-20/5
Guide Pads	Part No.	PAD-GP06-020-120	PAD-GP06-020-120	PAD-GP07-020-120	PAD-GP07-020-120	PAD-GP08-025-155
	Screw	SR34-508	SR34-508	CSTB3S	CSTB-3S	CSTB-3S
	Wrench	T-7F	T-7F	T-9F	T-9F	T-9F



DEEPTRIO™ PARTS LIST - MC/GD

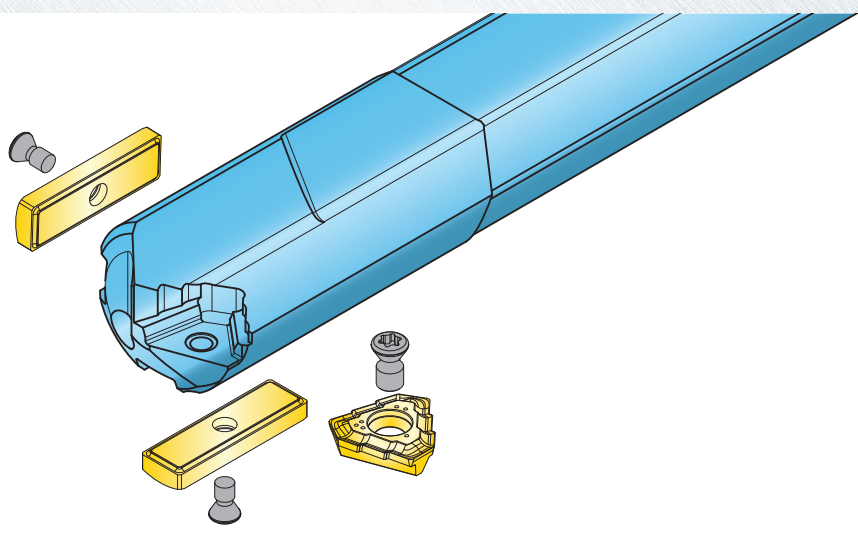

Components		Drill Diameter (inch)					
		.313-.334	.335-.354	.355-.393	.394-.432	.433-.464	.465-.471

Insert	Part No.	ZPHT040104R	ZPHT040104R	ZPHT050104R	ZPHT060204R	ZPHT060204R	LPHT060204R
	Screw	CSPB-2FL3.1	CSPB-2FL3.1	CSPB-2FL3.1	SR-M2.5X0.35L3.8	SR-M2.5X0.35L3.8	SR10503833L040
	Wrench	IP-6F	IP-6F	IP-6F	T-7F	T-7F	T-7F
Guide Pads	Part No.	PAD-GP03-012-035	PAD-GP03-012-040	PAD-GP03-012-040	PAD-GP04-016-045	PAD-GP04-016-050	PAD-GP04-016-050
	Screw	CSPB-2FL2.7-LH	CSPB-2FL3.1	CSPB-2FL3.1	CSTB-2	CSTB-2	CSTB-2
	Wrench	IP-6F	IP-6F	IP-6F	T-6F-S	T-6F-S	T-6F-S

Components		Drill Diameter (inch)					
		.472-.550	.551-.629	.630-.708	.709-.787	.788-.826	.827-.865

Insert	Part No.	LPHT060204R	TPHT070304R	TPHT080305R	TPHT090305R	TPHT100305R	TPHT100305R
	Screw	SR10503833L040	SR14-560/S	SR14-560/S	SR14-560/S	SR34-506	SR34-506
	Wrench	T-7F	T-8F	T-8F	T-8F	T-9F	T-9F
Guide Pads	Part No.	PAD-GP04-016-055	PAD-GP05-018-060	PAD-GP05-018-075	PAD-GP06-020-085	PAD-GP06-020-085	PAD-GP06-020-100
	Screw	CSPB-2L043	SR34-508	SR34-508	SR34-508	SR34-508	SR34-508
	Wrench	IP-6F	T-7F	T-7F	T-7F	T-7F	T-7F

Components		Drill Diameter (inch)			
		.866-.984	.985-1.102	1.103-1.180	1.181-1.260

Insert	Part No.	TPHT110405R	TPHT120405R	TPHT130408R	TPHT130408R
	Screw	SR14-571/S	SR14-506	SR16-212/L10	SR16-212/L10
	Wrench	T-15F	T-15F	T-20/5	T-20/5
Guide Pads	Part No.	PAD-GP06-020-100	PAD-GP06-020-120	PAD-GP06-020-120	PAD-GP07-020-120
	Screw	SR34-508	SR34-508	SR34-508	CSTB-3L065
	Wrench	T-7F	T-7F	T-7F	T-9F

DEEPTRIO™ DIAMETER ADJUSTING SHIMS

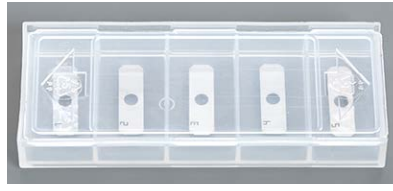
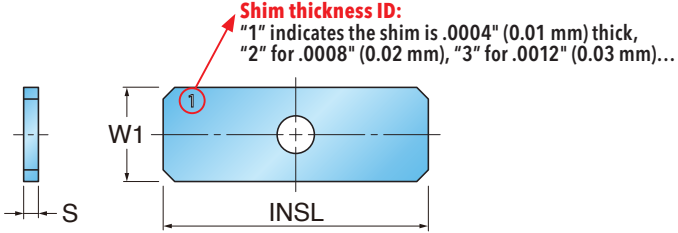

0.01 mm / 0.02 mm / 0.03 mm / 0.04 mm / 0.05 mm
 .0004" / .0008" / .0012" / .0016" / .0020"

Part Number	W1 Width inch (mm)	INSL Length inch (mm)	S Thickness inch (mm)	Application Guide Pad Size
NEW SHIMSET-GP03	.136 (3.45)	.449 (11.4)	.0004-.0020 (0.01-0.05)	PAD-G003
SHIMSET-GP04	.157 (4)	.626 (15.9)	.0004-.0020 (0.01-0.05)	PAD-G004
SHIMSET-GP05	.197 (5)	.709 (18)	.0004-.0020 (0.01-0.05)	PAD-G005
SHIMSET-GP06	.236 (6)	.787 (20)	.0004-.0020 (0.01-0.05)	PAD-G006

- A shim set contains 5 shims in thicknesses of .0004" (0.01 mm), .0008" (0.02 mm), .0012" (0.03 mm), .0016" (0.04 mm) and .0020" (0.05 mm), respectively.
- **Adjusting shims are sold by set only, not to be sold separately.**

Diameter Adjustments inch (mm)	Shim(s) for measuring guide pad inch (mm)	Shim(s) for supporting guide pad inch (mm)	Number of shim sets needed
+0.0004 (+0.01)	.0004 (0.01)	-	1
+0.0008 (+0.02)	.0008 (0.02)	.0004 (0.01)	1
+0.0012 (+0.03)	.0012 (0.03)	.0004 + .0008 (0.01 + 0.02)	1
+0.0016 (+0.04)	.0016 (0.04)	.0004 + .0012 (0.01 + 0.03)	1
+0.0020 (+0.05)	.0020 (0.05)	.0008 + .0012 (0.02 + 0.03)	1
+0.0024 (+0.06)	.0004 + .0020 (0.01 + 0.05)	.0008 + .0016 (0.02 + 0.04)	1
+0.0028 (+0.07)	.0008 + .0020 (0.02 + 0.05)	.0012 + .0016 (0.03 + 0.04)	1
+0.0031 (+0.08)	.0012 + .0020 (0.03 + 0.05)	.0016 + .0016 (0.04 + 0.04)	2
+0.0035 (+0.09)	.0016 + .0020 (0.04 + 0.05)	.0016 + .0020 (0.04 + 0.05)	2
+0.0039 (+0.10)	.0020 + .0020 (0.05 + 0.05)	.0016 + .0016 + .0008 (0.04 + 0.04 + 0.02)	2

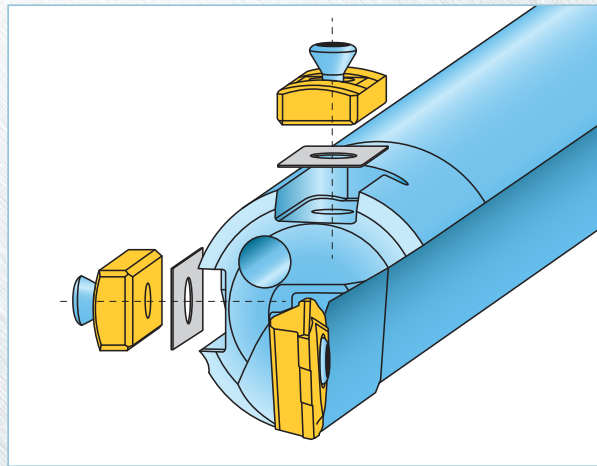

DEEPTRIO™ HOW TO INSTALL ADJUSTING SHIMS

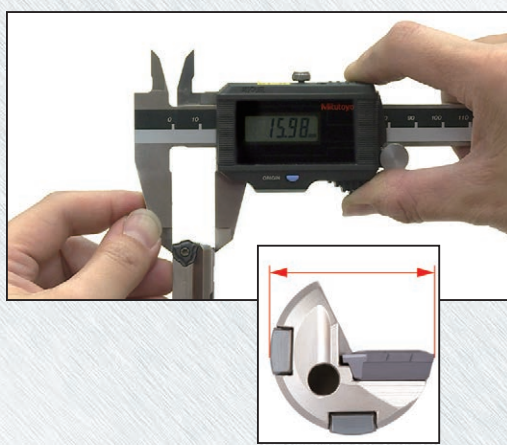

STEP 1:
Measure the DeepTrio drill diameter between the measuring guide pad and the insert cutting edge. If a presetter is not available, use a micrometer or caliper.
For a precise drill diameter measurement, it is recommended to test-drill a hole and measure the hole diameter.

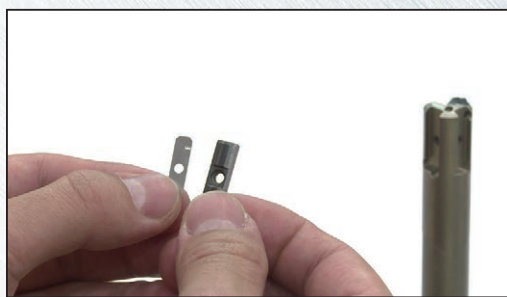

STEP 2:
Select the shim combinations according to the chart on page 26 to obtain the required hole diameter. Take into consideration that the actual diameter of the drilled hole tends to be slightly larger (usually +.0008" to +.0012") than the drill's nominal diameter – i.e. add .0008"-.0012" to the measured drill diameter in Step 1 above before the final drill diameter.

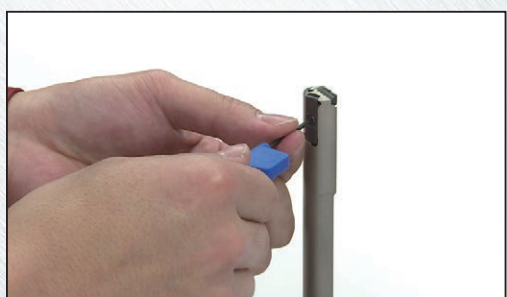

STEP 3:
Remove the guide pads.



STEP 5:
Measure the drill diameter again to confirm the required diameter is obtained on the DeepTrio.

STEP 6:
Test drill a hole to confirm that the required hole diameter is achieved.



DEEPTRIO™ TRH HEAD

Now Available! The TRH brazed head of the DeepTrio tools are now available as a separate item which allows customers to repair their DeepTrio tools by brazing a new head onto the body after removing the old one.

	Type	Part Number	DC	BD	LH
	1 insert type (metric)	TRH-08.00MKT	8.00	7.70	39.80
		TRH-08.50MKT	8.50	8.00	39.80
		TRH-08.50MKT	9.00	8.60	39.70
		TRH-08.50MKT	9.50	9.00	39.70
		TRH-08.50MKT	10.00	9.60	42.80
		TRH-08.50MKT	10.50	9.90	42.80
		TRH-08.50MKT	11.00	10.50	42.80
		TRH-08.50MKT	11.50	11.00	42.80
		TRH-08.50MKT	12.00	11.50	42.80
		TRH-08.50MKT	12.50	12.00	42.80
		TRH-08.50MKT	13.00	12.50	42.80
		TRH-08.50MKT	13.50	13.00	42.80
		TRH-08.50MKT	14.00	13.70	50.10
		TRH-08.50MKT	14.50	14.20	50.10
		TRH-08.50MKT	15.00	14.70	50.10
		TRH-08.50MKT	16.00	15.70	50.20
		TRH-08.50MKT	16.50	16.00	50.20
		TRH-08.50MKT	17.00	16.50	50.20
		TRH-08.50MKT	17.50	17.20	50.20
		TRH-08.50MKT	18.00	17.40	50.20
		TRH-08.50MKT	18.50	18.00	50.30
		TRH-08.50MKT	19.00	18.40	50.30
		TRH-08.50MKT	19.50	18.90	50.30
		TRH-08.50MKT	20.00	19.40	50.30
		TRH-08.50MKT	21.00	20.40	50.30
		TRH-08.50MKT	22.00	21.70	50.30
		TRH-08.50MKT	23.00	22.40	50.30
		TRH-08.50MKT	24.00	23.40	50.30
		TRH-08.50MKT	25.00	24.40	50.30
		TRH-08.50MKT	26.00	25.40	50.30
TRH-08.50MKT	27.00	26.40	50.30		
TRH-08.50MKT	28.00	27.40	50.30		
	1 insert type (inch)	TRH-12.70MKT	0.500	0.480	1.970
		TRH-14.30MKT	0.563	0.539	1.972
		TRH-15.90MKT	0.626	0.598	1.976
		TRH-19.10MKT	0.752	0.724	1.980
		TRH-20.60MKT	0.811	0.783	1.980
		TRH-22.20MKT	0.874	0.862	1.980
		TRH-23.80MKT	0.937	0.921	1.980
		TRH-25.40MKT	1.000	0.980	1.980
	Cross hole type	TRH-14.00CHMKT	14.00	13.70	50.10
		TRH-15.00CHMKT	15.00	14.70	50.10
		TRH-16.00CHMKT	16.00	15.70	52.20
		TRH-17.00CHMKT	17.00	16.50	52.20
		TRH-18.00CHMKT	18.00	17.40	52.20
		TRH-19.00CHMKT	19.00	18.40	53.30
		TRH-20.00CHMKT	20.00	19.40	53.30
		TRH-22.00CHMKT	22.00	21.70	56.30
		TRH-23.00CHMKT	23.00	22.40	56.30
		TRH-24.00CHMKT	24.00	23.40	56.30
		TRH-25.00CHMKT	25.00	24.40	56.30
		TRH-26.00CHMKT	26.00	25.40	57.30
TRH-27.00CHMKT	27.00	26.40	57.30		
TRH-28.00CHMKT	28.00	27.40	57.30		

DEEPTRIO™ DRILLING PROCESS (STARTING)

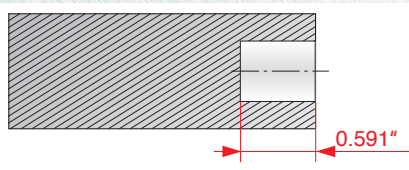

1. Pilot Hole
Drill Diameter +0.0039" ~ +0.0012"
Depth = 0.591"

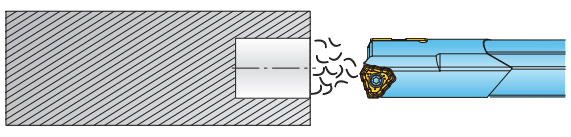

2. Approach - Rapid, Coolant On
Vc = 100 RPM Max
f = 0.02" ~ 0.039"/rev
Depth = 0.394"

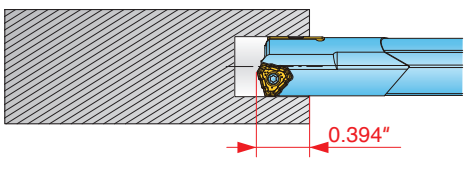

3. Enter Pilot Hole, Begin Drilling
0.394" ~ 0.984"
Vc: 100 %
f: 80 %

4. Drill Feed After 1.00"
Vc: 100 %
f: 100 %

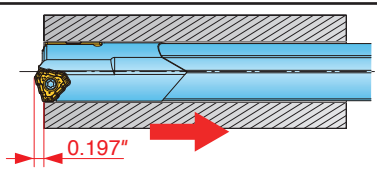

5. Retract. Stop rotation and coolant before moving the drill back to starting position.

DEEPTRIO™ DRILLING PROCESS (CROSS-HOLES)

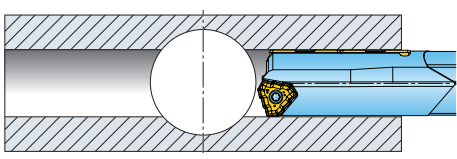

1. 1-2 mm before cross-hole
Reduce feed by 30 - 50%
Maintain same RPM

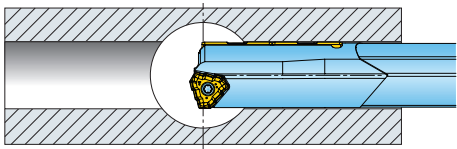

2. Cross through hole
Maintain same RPM

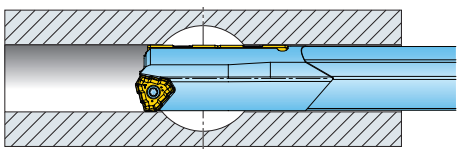

3. 1-2 mm after cross-hole.
Resume original feed rate and RPM

***NOTE:**
Possible risks: To prevent injuries, do NOT operate any deep hole drill, which uses pre-drilled pilot hole, at full speed before entering the pilot hole. The deep hole drill may fracture due to vibration and cause injuries.
Counter measures: Do NOT operate the deep hole drill at full speed before engaging the pilot hole. Enter the pilot hole slowly at a speed of 50-100 RPM.



DEEPTRIO^{BTA}™ OPERATING PARAMETERS - DT* CHIP BREAKER

*NOTE: DT-P inserts available ONLY for N (non-ferrous) ISO category; DT inserts available for all categories noted below.

ISO	Material	Condition	Speed (SFM)	Feed (inch/rev) Drill Diameter (inch)			
				.551-.708" (14-18 mm)	.709-1.102" (18.01-28 mm)	1.103-1.575" (28.01-40 mm)	
P	1	Low Carbon Steels (C <0.3)	262-459	.002-.004	.002-.004	.003-.006	
	2						
	3						
	4	Carbon Steels (C>0.3)		.002-.006	.002-.008	.002-.008	
	5						
	6	Low Alloy Steels		.002-.004	.002-.004	.003-.006	
	7						
	8						
	9						
	10	Alloy Steels		.002-.006	.003-.008	.002-.008	
	11						
M	12	Stainless Steels (Ferritic)	197-328	.002-.004	.002-.004	.002-.004	
	13	Stainless Steels (Martensitic)					
	14	Stainless Steels (Austenitic)					
K	15	Grey Cast Iron	262-459	.002-.010	.003-.012	.003-.012	
	16						
	17	Nodular Cast Iron					
	18						
	19						
20	Malleable Cast Iron						
N*	21	Aluminum Alloy Forging	328-656	.002-.008	.002-.008	.002-.008	
	22						
	23	Aluminum Alloy Casting					
	24						
	25						
	26	Copper Alloy					
	27						
	28						
	29	Non-Metallic					
	30						
S	31	High Temp Alloy, Inconel 718, etc.	66-164	.002-.003	.002-.004	.002-.005	
	32						
	33						
	34						
	35						
	36						Titanium Alloy, Ti-Al-4V, etc.
	37						
H	38	Hardened Steel >40HRC	164-328	.002-.003	.002-.004	.002-.004	
	39						
	40						Chilled Cast Iron
	41						Cast Iron-Hardened



DEEPTRIO^{BTA}™ OPERATING PARAMETERS - ML CHIP BREAKER

ISO	Material	Condition	Speed (SFM)	Feed (inch/rev) Drill Diameter (inch)		
				.551-.708" (14-18 mm)	.709-1.102" (18.01-28 mm)	1.103-1.575" (28.01-40 mm)
P	1	Low Carbon Steels (C <0.3)	164-328	.001-.004	.001-.004	.002-.003
	2					
	3					
	4	Carbon Steels (C>0.3)		.001-.004	.001-.005	.002-.006
	5					
	6	Low Alloy Steels		.001-.004	.001-.004	.002-.003
	7					
	8					
	9					
	10	Alloy Steels		.001-.004	.001-.005	.002-.006
	11					
M	12	Stainless Steels (Ferritic)	164-328	.001-.004	.001-.004	.001-.004
	13	Stainless Steels (Martensitic)				
	14	Stainless Steels (Austenitic)				
K	15	Grey Cast Iron	164-328	.001-.010	.002-.007	.002-.007
	16					
	17	Nodular Cast Iron				
	18					
	19	Malleable Cast Iron				
20						
N	21	Aluminum Alloy Forging	262-525	.001-.006	.001-.006	.001-.006
	22					
	23					
	24	Aluminum Alloy Casting				
	25					
	26	Copper Alloy				
	27					
	28					
	29	Non-Metallic				
	30					
S	31	High Temp Alloy, Inconel 718, etc.	66-164	.001-.002	.001-.003	.002-.003
	32					
	33					
	34					
	35					
	36					
37						
H	38	Hardened Steel >40HRC	131-328	.001-.003	.001-.003	.001-.003
	39					
	40	Chilled Cast Iron				
	41	Cast Iron-Hardened				



DEEPTRIOMC™ & DEEPTRIOGD™ OPERATING PARAMETERS - DT* CHIP BREAKER-SMALL DIA.

*NOTE: DT-P inserts available ONLY for N (non-ferrous) ISO category; DT inserts available for all categories noted below.

ISO	Material	Condition	Speed (SFM)	Feed (inch/rev) Drill Diameter (inch)		
				.313-.393" (7.94-9.99mm)		
P	1	Low Carbon Steels (C <0.3)	197-328	.002-.006		
	2					
	3					
	4	Carbon Steels (C >0.3)		.002-.003		
	5					
	6	Low Alloy Steels		.002-.003		
	7					
	8					
	9					
	10	Alloy Steels		.002-.006		
	11					.002-.003
M	12	Stainless Steels (Ferritic)	197-328	.002-.003		
	13	Stainless Steels (Martensitic)				
	14	Stainless Steels (Austenitic)				197-262
K	15	Grey Cast Iron	197-328	.002-.008		
	16					
	17	Nodular Cast Iron				
	18					
	19	Malleable Cast Iron				
20						
N*	21	Aluminum Alloy Forging	197-328	.002-.007		
	22					
	23					
	24	Aluminum Alloy Casting				
	25					
	26	Copper Alloy				
	27					
	28	Non-Metallic				
	29					
	30					
S	31	High Temp Alloy, Inconel 718, etc.	66-164	.002-.002		
	32					
	33					
	34					
	35		Titanium Alloy, Ti-Al-4V, etc.	98-197	.002-.004	
	36					
	37					
H	38	Hardened Steel >40HRC	66-164	.002-.002		
	39					
	40					Chilled Cast Iron
	41					Cast Iron-Hardened



DEEPTRIOMC™ & DEEPTRIOGD™

OPERATING PARAMETERS - DT* CHIP BREAKER

*NOTE: DT-P inserts available ONLY for N (non-ferrous) ISO category; DT inserts available for all categories noted below.

ISO	Material	Condition	Speed (SFM)	Feed (inch/rev) Drill Diameter (inch)					
				.394-.465" (10-11.8 mm)	.466-.551" (11.81-13.99 mm)	.552-.709" (14-18 mm)	.710-1.260" (18.01-32 mm)	1.261-1.575" (32.01-40 mm)	
P	1	Low Carbon Steels (C <0.3)	262-459	.002-.003	.002-.004	.002-.005	.003-.006	.004-.010	
	2								
	3								
	4	Carbon Steels (C >0.3)		.002-.006	.002-.006	.003-.007	.003-.008	.004-.012	
	5								
	6	Low Alloy Steels		.002-.003	.002-.004	.002-.005	.003-.006	.004-.010	
	7								
	8								
	9								
	10	Alloy Steels		.002-.006	.002-.006	.003-.007	.003-.008	.004-.012	
	11								
M	12	Stainless Steels (Ferritic)	197-328	.002-.003	.002-.004	.002-.004	.002-.005	.004-.006	
	13	Stainless Steels (Martensitic)							
	14	Stainless Steels (Austenitic)							
K	15	Grey Cast Iron	262-459	.002-.008	.002-.010	.002-.010	.002-.010	.002-.012	
	16								
	17	Nodular Cast Iron							
	18								
	19	Malleable Cast Iron							
20									
N*	21	Aluminum Alloy Forging	328-656	.002-.007	.002-.008	.003-.009	.003-.009	.004-.012	
	22								
	23	Aluminum Alloy Casting							
	24								
	25								
	26	Copper Alloy							
	27								
	28	Non-Metallic							
	29								
	30								
S	31	High Temp Alloy, Inconel 718, etc.	66-164	.002-.003	.002-.003	.002-.003	.002-.004	.002-.005	
	32								
	33								
	34								
	35								
	36								Titanium Alloy, Ti-Al-4V, etc.
	37								
H	38	Hardened Steel >40HRC	164-328	.002-.003	.002-.003	.002-.003	.002-.004	.002-.005	
	39								
	40								Chilled Cast Iron
	41								Cast Iron-Hardened



DEEPTRIOMC™ & DEEPTRIOGD™

OPERATING PARAMETERS - ML CHIP BREAKER

ISO	Material	Condition	Speed (SFM)	Feed (inch/rev) Drill Diameter (inch)				
				.394-.465" (10-11.8 mm)	.466-.551" (11.81-13.99 mm)	.552-.709" (14-18 mm)	.710-1.260" (18.01-32 mm)	1.261-1.575" (32.01-40 mm)
P	1	Low Carbon Steels (C <0.3)	164-328	NA	NA	.001-.004	.001-.004	.001-.004
	2							
	3							
	4	Carbon Steels (C >0.3)		NA	NA	.001-.004	.001-.005	.001-.005
	5							
	6	Low Alloy Steels		NA	NA	.001-.005	.003-.004	.001-.004
	7							
	8							
	9							
	10	Alloy Steels		NA	NA	.001-.004	.001-.005	.001-.005
	11							
M	12	Stainless Steels (Ferritic)	164-328	NA	NA	.001-.002	.001-.002	.001-.004
	13	Stainless Steels (Martensitic)						
	14	Stainless Steels (Austenitic)						
K	15	Grey Cast Iron	164-328	NA	NA	.001-.006	.002-.005	.001-.006
	16							
	17	Nodular Cast Iron						
	18							
	19	Malleable Cast Iron						
20								
N	21	Aluminum Alloy Forging	262-525	NA	NA	.001-.006	.001-.006	.001-.008
	22							
	23							
	24	Aluminum Alloy Casting						
	25							
	26	Copper Alloy						
	27							
	28							
	29	Non-Metallic						
	30							
S	31	High Temp Alloy, Inconel 718, etc.	66-164	NA	NA	.001-.002	.001-.003	.001-.003
	32							
	33							
	34							
	35							
	36							
37								
H	38	Hardened Steel >40HRC	131-328	NA	NA	.001-.003	.001-.003	.001-.004
	39							
	40	Chilled Cast Iron						
	41	Cast Iron-Hardened						