



Diameters:
.625" - 2.000"

Insert Series:
MNHU06

Materials:
Cast Iron, Steel, Stainless Steel,
Aluminum, High-Temp Alloys

Depth of Cut:
.24"

90° Milling with 4 Cutting Edges; High Ramping Capability

With a dia. range of .625-2.000, Di-PosTetra 06 is an economical alternative to solid carbide end mills for 90° shoulder milling and backdraft semi-finishing applications on any NC Machine. And as many knee mills target .12" axial DOC or less, the end mill line now includes .750 dia. cylindrical shanks (that fit ER collets) with large dia. heads. 4-Edge economy makes this line a perfect fit for any machine!

Features & Benefits:

- Pockets designed with wide mounting area and strong M3.0 crew for utmost durability
- Fine pitch densities allow high productivity in Iron and Hi-Temperature alloys
- Coarse Pitch density and high positive rake angles provide low cutting forces on small machines
- Concave face design accommodates aggressive ramp, corkscrew and drill milling functions.
- Diverse adaption selection designed to accommodate any machine set up... including knee mills.
- All cutters ported with coolant through

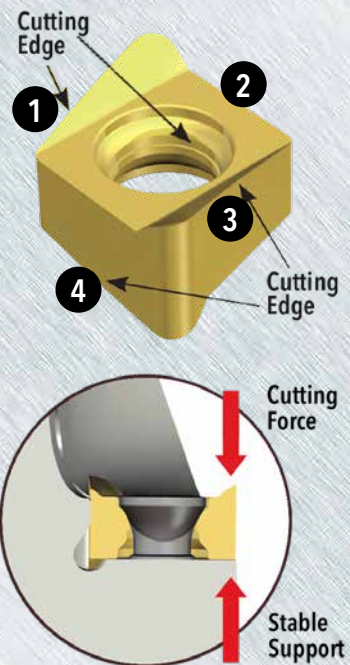

**PRODUCT
ANNOUNCEMENT
UPDATE
2018**

DIPOSOTETRA™ 06 SERIES 1TJ1D (WELDON SHANK STYLE) (6MM)

90° END MILL WITH 4 INDEXES

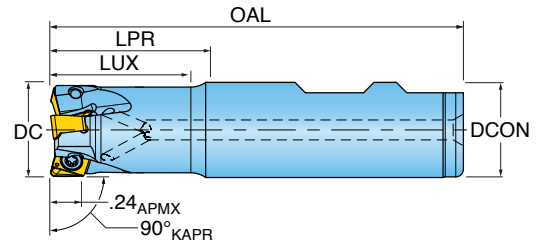

Part Number	DC Cutting Dia.	LPR Protruding Length	LUX Usable Length Max.	OAL Overall Length	ZEFF Eff. Teeth	DCON Shank Dia.	RPMX Ramp Angle Max.
1TJ1D-0600779R01	0.625	0.75	0.72	2.66	2	0.625	3.1
1TJ1D-0701284R01	0.750	1.25	1.20	3.25	3	0.750	4.1
1TJ1D-0801284R01	0.875	1.25	1.25	3.25	3	0.750	5.0
1TJ1D-1001780R01	1.000	1.75	1.72	4.00	4	1.000	4.8
1TJ1D-1001784R01	1.000	1.75	1.72	3.75	4	0.750	4.8
1TJ1D-1201781R01	1.250	1.75	1.72	4.00	5	1.250	3.6
1TJ1D-1201784R01	1.250	1.75	1.75	3.75	5	0.750	3.6
1TJ1D-1501784R01	1.500	1.75	1.75	3.75	6	0.750	2.8
1TJ1D-1502281R01	1.500	2.25	2.25	4.50	6	1.250	2.8

*Cutter Body must be relieved for use with insert corner radii larger than R.031"; (Body R = Insert R -.02")

DIPOSOTETRA™ 06 SERIES 1TJ1D (CYLINDRICAL SHANK STYLE) (6MM)

90° END MILL WITH 4 INDEXES

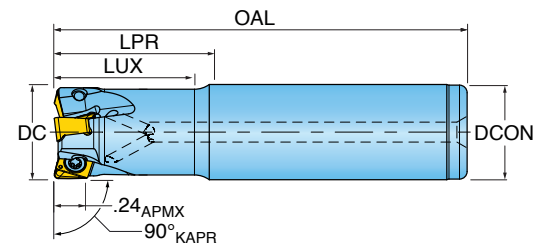

Part Number	DC Cutting Dia.	LPR Protruding Length	LUX Usable Length Max.	OAL Overall Length	ZEFF Eff. Teeth	DCON Shank Dia.	RPMX Ramp Angle Max.
1TJ1D-0602056R01	0.625	2.09	1.25	4.00	2	0.625	3.1
1TJ1D-0703057R01	0.750	3.00	1.25	5.00	3	0.750	4.1
1TJ1D-1003751R01	1.000	3.75	1.25	6.00	4	1.000	4.8
1TJ1D-1204259R01	1.250	4.25	1.25	6.50	5	1.250	3.6
1TJ1D-1504755R01	1.500	4.75	1.25	7.00	6	1.500	2.8

*Cutter Body must be relieved for use with insert corner radii larger than R.031"; (Body R = Insert R -.02")

DIPOSOTETRA™ 06 SERIES 1TJ1D (KNEE MILL STYLE) (6MM)

90° END MILL WITH 4 INDEXES

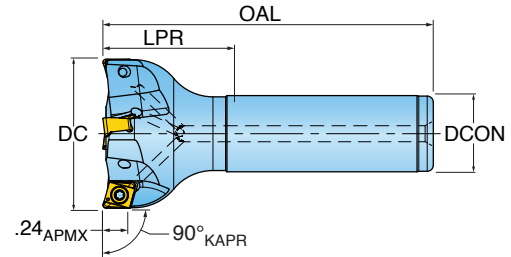

Part Number	DC Cutting Dia.	LPR Protruding Length	OAL Overall Length	ZEFF Eff. Teeth	DCON Shank Dia.	RPMX Ramp Angle Max.
1TJ1D-10012S7R01	1.000	1.25	3.25	3	0.750	4.8
1TJ1D-15012S7R01	1.500	1.25	3.25	4	0.750	2.8
1TJ1D-20012S7R01	2.000	1.25	3.25	5	0.750	2.0

*Cutter Body must be relieved for use with insert corner radii larger than R.031"; (Body R = Insert R -.02")

DIPOSOTETRA™ 06 SERIES 1TJ1D (TOP-ON STYLE) (6MM)

90° MODULAR END MILL WITH 4 INDEXES

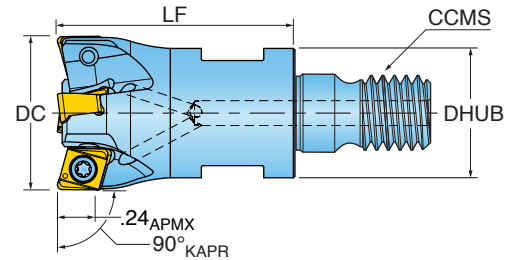

Part Number	DC Cutting Dia.	LF Functional Length	ZEFF Eff. Teeth	CCMS Connection Code	DHUB Hub Dia.	RPMX Ramp Angle Max.
1TJ1D-07015X6R01	0.750	1.50	3	M10	0.69	4.1
1TJ1D-10015X7R01	1.000	1.50	4	M12	0.81	4.8
1TJ1D-12017X8R01	1.250	1.75	5	M16	1.13	3.6
1TJ1D-15017X8R01	1.500	1.75	6	M16	1.13	2.8

*Cutter Body must be relieved for use with insert corner radii larger than R.031"; (Body R = Insert R -.02")

DIPOSOTETRA™ 06 SERIES 1TJ1D (CHIP•SURFER STYLE) (6MM)

90° MODULAR END MILL WITH 4 INDEXES

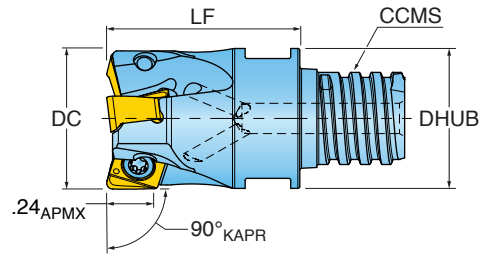

Part Number	DC Cutting Dia.	LF Protruding Length	ZEFF Eff. Teeth	CCMS Connection Code	DHUB Hub Dia.	RPMX Ramp Angle Max.
1TJ1D-06008TRR01	0.625	0.80	2	T10	0.61	3.1
1TJ1D-07010TSR01	0.750	1.00	3	T12	0.73	4.1
1TJ1D-10012TUR01	1.000	1.25	4	T15	0.95	4.8

*Cutter Body must be relieved for use with insert corner radii larger than R.031"; (Body R = Insert R -.02")

DIPOSOTETRA™ 06 SERIES 1TV1D (CHIP•SURFER STYLE) (6MM)

BACKDRAFT END MILL WITH 4 INDEXES

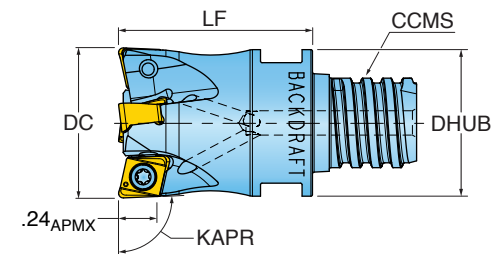

Part Number	DC Cutting Dia.	LF Protruding Length	ZEFF Eff. Teeth	CCMS Connection Code	DHUB Hub Dia.	RPMX Ramp Angle Max.	KAPR Cutting Edge Angle
1TV1D-06208TRR10	0.625	0.80	2	T10	0.60	3.0	91
1TV1D-07010TSR02	0.750	1.00	3	T12	0.72	4.7	93
1TV1D-10012TUR02	1.000	1.25	4	T15	0.95	3.9	93

*Cutter Body must be relieved for use with insert corner radii larger than R.031"; (Body R = Insert R -.02")

Notes:

- Recommend .020" maximum axial stepdown on straight wall finish applications.
- Well suited for long reach applications.

DIPOSOTETRA™ 06 SERIES TJ1D (6MM)

90° FACE MILL WITH 4 INDEXES

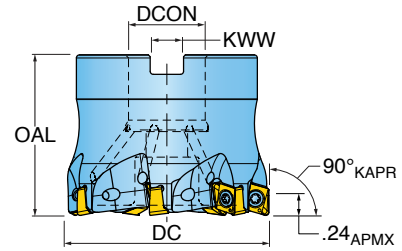

Part Number	DC Cutting Dia.	OAL Overall Length	ZEFF Eff. Teeth	DCON Bore Dia.	KWW Keyway	RPMX Ramp Angle Max.
TJ1D-15R01	1.500	1.57	6	0.500	0.250	2.8
TJ1D-20R01	2.000	1.57	7	0.750	0.312	2.0

*Cutter Body must be relieved for use with insert corner radii larger than R.031"; (Body R = Insert R -.02")

DIPOSOTETRA™ 06 INSERTS (6MM)

MNHU

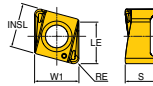

MNHU-PH

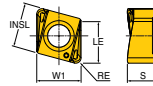



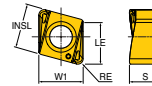



MNCU



Part Number	Application	RE/BCH Corner Radius/ Chamfer	LE Cutting Edge Length	INSL Length	W1 Width	S Thickness	NOI Number of Inserts	IH Insert Hand	Grade	IN 10K	IN 2035	IN 2505	IN 2510	IN 2530	IN 6515
MNHU060304R	Multi-Purpose	0.015 R	0.240	0.260	0.260	0.184	4	Right			•				•
MNHU060308R	Multi-Purpose	0.031 R	0.230	0.260	0.260	0.184	4	Right			•	•	•	•	•
MNHU060316R	Multi-Purpose	0.062 R	0.210	0.260	0.260	0.180	4	Right			•	•	•	•	•
MNHU060304R-PH	SS/Hi-Temp/Ti	0.015 R	0.240	0.260	0.260	0.184	4	Right			•				
MNHU060308R-PH	SS/Hi-Temp/Ti	0.031 R	0.230	0.260	0.260	0.184	4	Right			•	•		•	
MNHU060316R-PH	SS/Hi-Temp/Ti	0.062 R	0.210	0.260	0.260	0.180	4	Right			•	•		•	
MNCU060304FR-P	Aluminum	0.015 R	0.240	0.260	-	0.196	4	Right	•						
MNCU060308FR-P	Aluminum	0.031 R	0.230	0.260	0.260	0.190	4	Right	•						

DIPOS[®]TETRA™ 06 HARDWARE

							
	Screw	Driver	Torque Driver Bit (opt)	Torque Driver Handle (opt)	Retention Bolt	Wrench	Torque Wrench (opt)
1TJ1D-06020S6R01	SM30-068-30	DS-T08W	DS-T08QB	DTQ-11W	-	-	-
1TJ1D-07030S7R01	SM30-068-30	DS-T08W	DS-T08QB	DTQ-11W	-	-	-
1TJ1D-10037S1R01	SM30-068-30	DS-T08W	DS-T08QB	DTQ-11W	-	-	-
1TJ1D-12042S9R01	SM30-068-30	DS-T08W	DS-T08QB	DTQ-11W	-	-	-
1TJ1D-15047S5R01	SM30-068-30	DS-T08W	DS-T08QB	DTQ-11W	-	-	-
1TJ1D-0600779R01	SM30-068-30	DS-T08W	DS-T08QB	DTQ-11W	-	-	-
1TJ1D-0701284R01	SM30-068-30	DS-T08W	DS-T08QB	DTQ-11W	-	-	-
1TJ1D-0801284R01	SM30-068-30	DS-T08W	DS-T08QB	DTQ-11W	-	-	-
1TJ1D-1001780R01	SM30-068-30	DS-T08W	DS-T08QB	DTQ-11W	-	-	-
1TJ1D-1001784R01	SM30-068-30	DS-T08W	DS-T08QB	DTQ-11W	-	-	-
1TJ1D-1201781R01	SM30-068-30	DS-T08W	DS-T08QB	DTQ-11W	-	-	-
1TJ1D-1201784R01	SM30-068-30	DS-T08W	DS-T08QB	DTQ-11W	-	-	-
1TJ1D-1501784R01	SM30-068-30	DS-T08W	DS-T08QB	DTQ-11W	-	-	-
1TJ1D-1502281R01	SM30-068-30	DS-T08W	DS-T08QB	DTQ-11W	-	-	-
1TJ1D-10012S7R01	SM30-068-30	DS-T08W	DS-T08QB	DTQ-11W	-	-	-
1TJ1D-15012S7R01	SM30-068-30	DS-T08W	DS-T08QB	DTQ-11W	-	-	-
1TJ1D-20012S7R01	SM30-068-30	DS-T08W	DS-T08QB	DTQ-11W	-	-	-
1TJ1D-07015X6R01	SM30-068-30	DS-T08W	DS-T08QB	DTQ-11W	-	615MM	-
1TJ1D-10015X7R01	SM30-068-30	DS-T08W	DS-T08QB	DTQ-11W	-	617MM	-
1TJ1D-12017X8R01	SM30-068-30	DS-T08W	DS-T08QB	DTQ-11W	-	622MM	-
1TJ1D-15017X8R01	SM30-068-30	DS-T08W	DS-T08QB	DTQ-11W	-	622MM	-
1TJ1D-06008TRR01	SM30-068-30	DS-T08W	DS-T08QB	DTQ-11W	-	WS-0044	DT-250-13
1TJ1D-07010TSR01	SM30-068-30	DS-T08W	DS-T08QB	DTQ-11W	-	WS-0059	DT-250-16
1TJ1D-10012TUR01	SM30-068-30	DS-T08W	DS-T08QB	DTQ-11W	-	WS-0061	-
1TV1D-06208TRR10	SM30-068-30	DS-T08W	DS-T08QB	DTQ-11W	-	WS-0044	DT-250-13
1TV1D-07010TSR02	SM30-068-30	DS-T08W	DS-T08QB	DTQ-11W	-	WS-0059	DT-250-16
1TV1D-10012TUR02	SM30-068-30	DS-T08W	DS-T08QB	DTQ-11W	-	WS-0061	-
TJ1D-15R01	SM30-068-30	DS-T08W	DS-T08QB	DTQ-11W	SD-04-46	-	-
TJ1D-20R01	SM30-068-30	DS-T08W	DS-T08QB	DTQ-11W	SD-06-46	-	-

DIPOS[®]TETRA™ 06 OPERATING GUIDELINES

DiPos TETRA - Series 1TJ1D, 1TV1D, TJ1D					Grades						Coolant
Material	Brinnell Hardness	SFM	Feed per Insert	IN10K	IN2505	IN2510	IN2530	IN2035	IN6515		
Aluminum	6061 T6, 7075 T6, 2024	-	1500 - 8000	.003 - .007	1						Yes
Cast Iron	Gray	150 - 250	300 - 1000	.003 - .006		3	1			2	No
	Nodular		300 - 600			3	2			1	
Steel	Low Carbon 1018, 8620	150 - 250	400 - 1000	.003 - .006		2	1				No
	High Carbon F-6180, Nitralloy 52100	250 - 400	350 - 500	.003 - .006							
	Alloyed Steel 4140, 4340, 6150	150 - 300	300 - 700	.003 - .006							
	Tool Steel A-6, D-1, D-2, P20	Up to 300									
Stainless Steel	300 Series, 304, 316	-	300 - 550	.003 - .005		3	2	1			May not be required at high speeds
	400 Series 15-5 PH, 17-4 PH	Up to 320	350 - 600								Yes
	13-8 PH	-	200 - 400								
Nickel Alloys	Inconel 600, 706, 718, 903, Hastelloy, Waspalloy	-	75-120	.003 - .005		2	3	1			Yes
Titanium	6AL-4V	-	100 - 150	.003 - .005		3	2	1			Yes

DIPOS[®]TETRA™ 06 DRILL MILL POCKETING

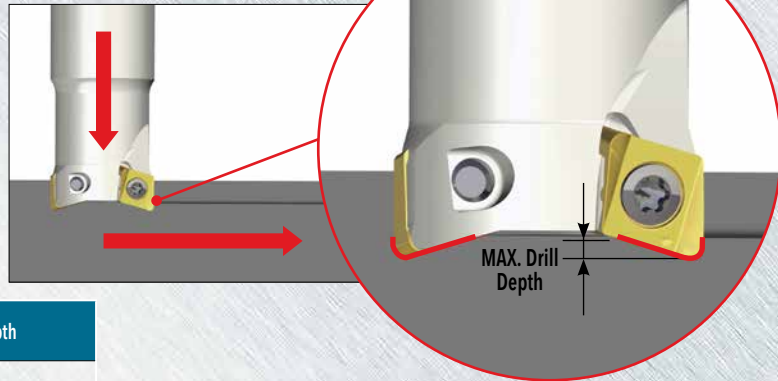
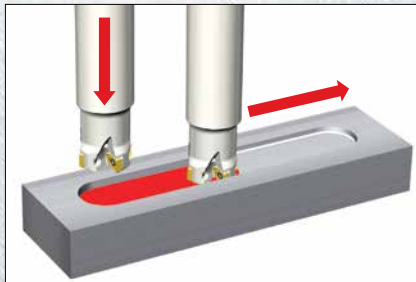

Cutter Dia.	MAX. Drill Depth
0.62	0.025"
0.75	0.039"
1.00	0.060"
1.25	0.060"
1.50	0.060"
2.00	0.060"

DIPOS[®]TETRA™ 06 STRAIGHT RAMPING DATA

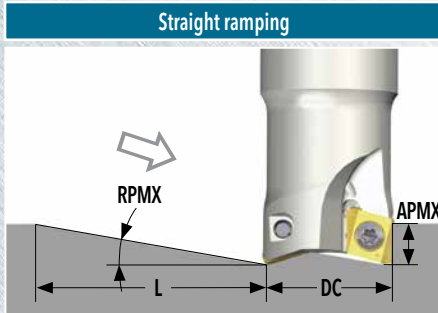

DC Cutter Diameter	RPMX Ramping Angle Max.	L	APMX Max. DOC
0.62	3.1	3.7	0.20
0.75	4.1	2.8	0.20
1.00	4.8	2.4	0.20
1.25	3.6	3.2	0.20
1.50	2.8	4.1	0.20
2.00	2.0	5.7	0.20

DIPOS[®]TETRA™ 06 HELICAL RAMPING DATA

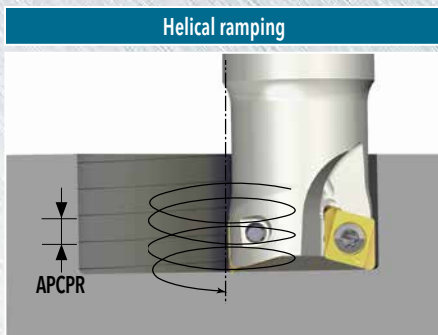

DC Cutter Dia. Using R.031 Insert	DMIN MIN. Dia. Milled Hole	APCPRN MIN. Advance Per Cutter Path Rev.	DMAX MAX. Dia. Milled Hole	APCPRX MAX. Advance Per Cutter Path Rev.
0.62	1.01	0.065	1.25	0.106
0.75	1.16	0.092	1.50	0.168
1.00	1.51	0.135	2.00	0.235
1.25	2.01	0.150	2.50	0.235
1.50	2.51	0.155	3.00	0.230
2.00	3.51	0.165	4.00	0.219