

OPERATING GUIDELINES - HIGH FEED

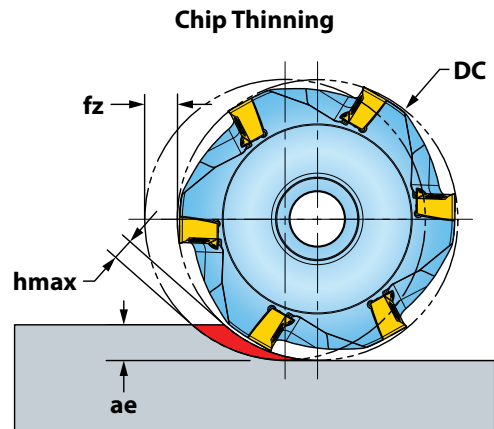

* Chip Thinning Calculator is recommended to ensure h_{max} is within f_z range.

Materials				Vc Cutting Speed SFM	fz* Feed/Tooth (inch)	Grade	Coolant
ISO	Mat'l Group #VDI 3323	Type	Examples			Carbide	
						IN2530	
P	1 thru 5	Non-alloy Steel	1018, A36, 1045, A572, 1070	400-1000	.020-.040	1	No
	6 thru 9	Low-alloy Steel	4140, 4340, P20, 8620, 300M	350-500			
	10, 11	High-alloy Steel	H13, A2, D2, M2, T1	300-700			
M	12 thru 13	Stainless Steel (Ferritic & Martensitic)	410, 416, 440	350-600	.020-.030	1	Yes
	14	Stainless Steel (Austenitic)	303, 304, 316, 15-5, 17-4	300-550			May not be required at high speeds
K	15 thru 16	Gray Cast Iron	CLS. 20, 30, 45	300-1000	.020-.040	1	No
	17 thru 20	Nodular Cast Iron	60-40-18, 100-70-03	300-600			
S	31 thru 35	High-Temp Alloys	Inconel, Hastelloy, Nimonic, Monel	75-120	.020-.030	1	Yes
	36 thru 37	Titanium Alloys	6Al-4V, 5Al-5Mo-5V-3Cr	100-150			
H	38 thru 39	Hardened Steel >48	A2, O1, D2	165-360	.020-.030	1	Yes

Note: Feed and speed recommendations are starting operating parameters. They are only guidelines from which further optimization should take place. Operating parameters are influenced by many machining variables. These variables may cause for reductions in feeds and speed or dramatic increases. Additionally, DOC and WOC may need to be revised to optimize the tools performance.