



Cutter Series (Depth of Cut):
1DJ1E / DJ5E / DJ6E (.19)
DJ5G / DJ6G (.33)

Insert Series:
SQU07
SQU12 / SOXU12

Diameter Range:
.625" - 6.000"
16mm - 50mm

Lead Angles:
90°

Corner Radius:
.031"

Materials:
Cast Iron, Steel, Hard Steel

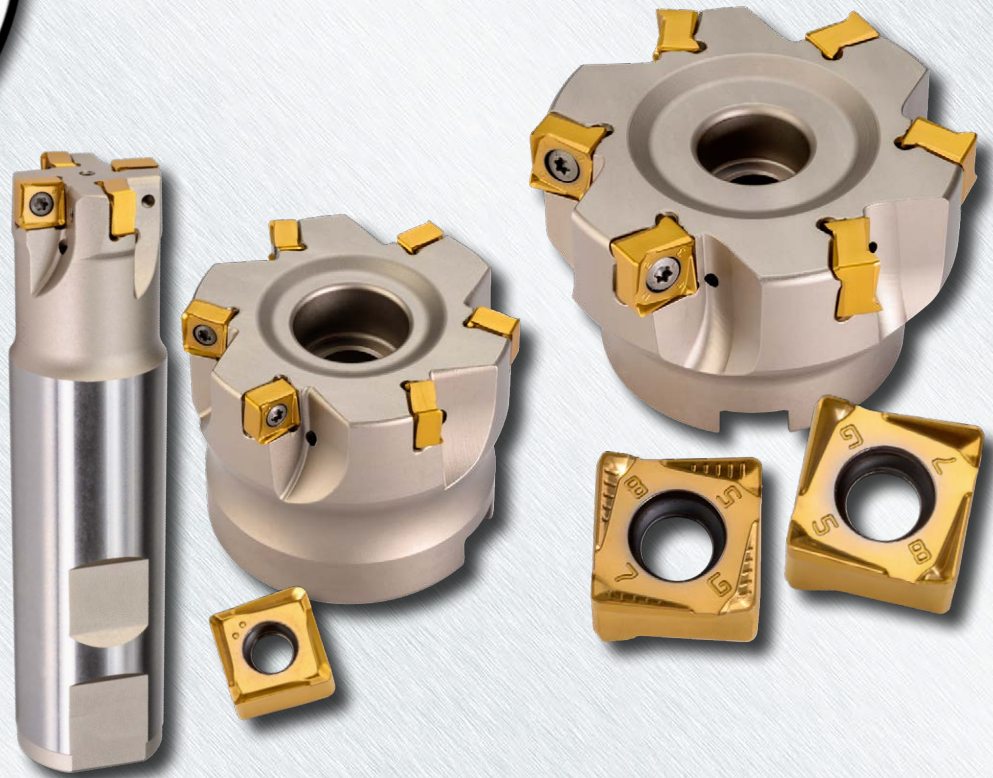

True 90° Shoulder Mills with 8-Edge Economy

Ingersoll's new DiPosQuad line utilizes 2-Side-Technology to offer economical 8-Corner inserts that generate true 90° shoulders and smooth surface finishes. Medium and fine pitch cutter offerings compliment the geometry for premium performance on small and medium platforms & workpieces.

Features & Benefits:

- High axial rake reduces cutting loads and promotes smooth machining
- 07 Insert generates true 90° and is optimized to step down axially with minimal mismatch
- 12 Insert generates true 90° up to .33 depth of cut
- Unequally spaced insert placement aids to diffuse vibration
- Integrated wiper flats produce 32-63 Ra surface finishes



DIPOSQUAD™ AXIAL STEP DOWN

Ingersoll's DiPosQuad family of cutters is capable of true 90° machining despite being a double-sided insert; the high axial geometry reduces cutting loads and vibration during machining yet achieves high productivity. Further advantages include the optimized design that enables minimal mismatch during 90° step machining with the 7mm insert, and improved surface finish of the workpiece due to the inclusion of a flat bottom wiper on the insert.

With a wide variety of inserts and cutter sizes available for end mills, modular types and face mills, the line enables excellent performance in applications where small and medium workpieces are involved.

07mm insert



- Generates true 90°
- Optimized to step down axially with minimal mismatch
- 8-corner double-sided insert
- Insert's bottom wiper provides improved surface finish
- Reduced machining load due to a high positive axial rake angle

12mm insert

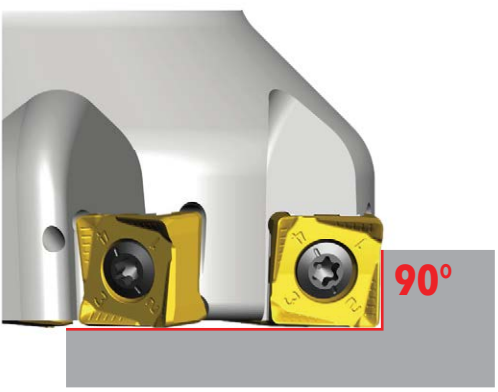

- Generates true 90° up to .33" depth of cut



Beyond .33" axial depth of cut, insert clearance is insufficient to step down the wall without mismatch



DIPOSQUAD™ 07 SERIES 1DJ1E

90° ROUGH & FINISH END MILL (7MM INSERT)

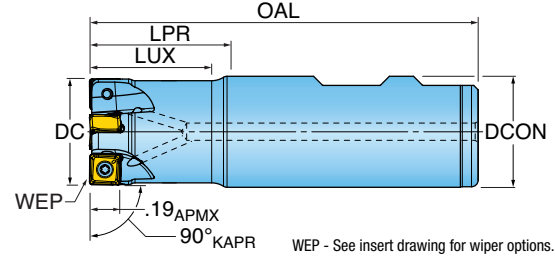
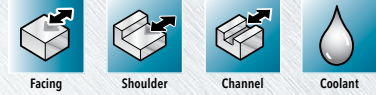

Part Number	DC Cutting Dia.	LUX Usable Length Max.	LPR Protruding Length	OAL Overall Length	ZEFF Eff. Teeth	DCON Shank Dia.
-------------	-----------------	------------------------	-----------------------	--------------------	-----------------	-----------------

INCH

1DJ1E-0600779R01	0.625	0.70	0.75	2.66	2	0.625
1DJ1E-0701084R01	0.750	0.95	1.00	3.00	3	0.750
1DJ1E-1001280R01	1.000	1.20	1.25	3.50	4	1.000
1DJ1E-1201581R01	1.250	1.45	1.50	3.75	4	1.250
1DJ1E-1201581R02	1.250	1.45	1.50	3.75	6	1.250
1DJ1E-1501786R01	1.500	1.70	1.75	4.41	5	1.500
1DJ1E-1501786R02	1.500	1.70	1.75	4.41	8	1.500

METRIC

1DJ1E016020W3R00	16.00 mm	20.0 mm	23.0 mm	90.0 mm	2	16.00 mm
1DJ1E020025W4R00	20.00 mm	25.0 mm	28.0 mm	90.0 mm	3	20.00 mm
1DJ1E025030W5R00	25.00 mm	30.0 mm	33.0 mm	100.0 mm	4	25.00 mm
1DJ1E032035W6R00	32.00 mm	35.0 mm	38.0 mm	110.0 mm	6	32.00 mm



DIPOSQUAD™ 07 SERIES 1DJ1E: TOPON™

90° ROUGH & FINISH END MILL (7MM INSERT)

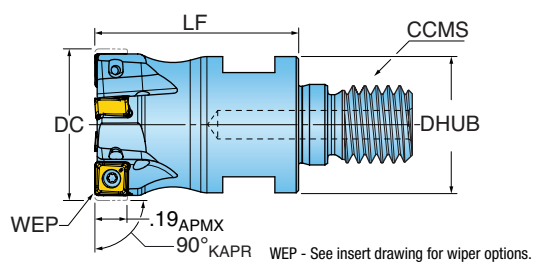
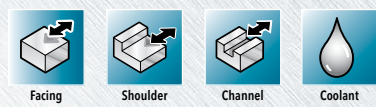

Part Number	DC Cutting Dia.	LF Functional Length	ZEFF Eff. Teeth	CCMS Connection Code Machine Side	DHUB Hub Dia.
-------------	-----------------	----------------------	-----------------	-----------------------------------	---------------

METRIC

1DJ1E016023X5R00	16.00 mm	23.0 mm	2	TopOn M08	13.0 mm
1DJ1E020030X6R00	20.00 mm	30.0 mm	3	TopOn M10	18.0 mm
1DJ1E025035X7R00	25.00 mm	35.0 mm	3	TopOn M12	21.0 mm
1DJ1E032043X8R00	32.00 mm	43.0 mm	4	TopOn M16	29.0 mm
1DJ1E040043X8R00	40.00 mm	43.0 mm	5	TopOn M16	29.0 mm



DIPOSQUAD™ 07 SERIES DJ5E, DJ6E

90° ROUGH & FINISH FACE MILL (7MM INSERT)

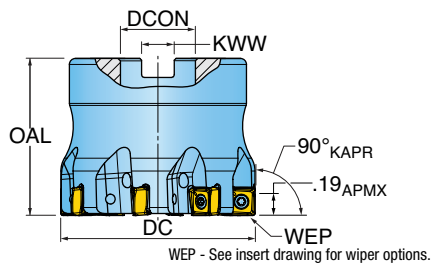
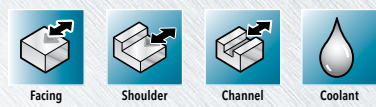

Part Number	DC Cutting Dia.	OAL Overall Length	ZEFF Eff. Teeth	DCON Bore Dia.	KWW Keyway
INCH					
DJ5E-15R01	1.500	1.57	6	0.500	0.250
DJ5E-20R01	2.000	1.57	8	0.750	0.312
DJ6E-20R01	2.000	1.57	6	0.750	0.312
DJ5E-25R01	2.500	1.57	10	1.000	0.375
DJ6E-25R01	2.500	1.57	7	1.000	0.375
DJ5E-30R01	3.000	1.75	12	1.000	0.375
DJ6E-30R01	3.000	1.75	8	1.000	0.375
METRIC					
DJ5E032R00	32.00 mm	32.00 mm	4	16.00 mm	8.40 mm
DJ5E040R00	40.00 mm	40.00 mm	6	16.00 mm	8.40 mm
DJ5E050R00	50.00 mm	40.00 mm	8	22.00 mm	10.40 mm



DIPOSQUAD™ 07 INSERT

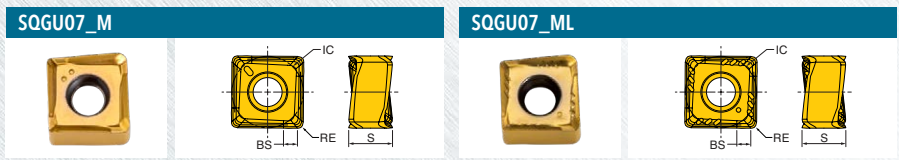
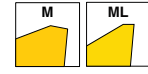

Part Number	Application	RE Corner Radius	BS Wiper Length	IC Inscribed Circle Dia.	S Thickness	NOI Number of Indexes	IH Insert Hand	Grade	IN2505	IN2510	IN2530
SQGU070408TR-M	Multi-Purpose - Integrated Wiper	0.031	0.035	0.275	0.165	8	Right		•	•	•
SQGU070408TR-ML	SS/Hi-Temp/Ti - Integrated Wiper	0.031	0.035	0.275	0.163	8	Right		•		•

DIPOSQUAD™ 07 HARDWARE

	Screw	Torx Screwdriver	Retention Bolt	Coolant Retention Bolt	Torque Driver Handle	Preset Torque Bit	Torque Driver Bit
1DJ1E-0600779R01	SM25-060-90	DS-TP07S	-	-	DS-A00-.25-S	DT-08-.25	DS-TP07B1
1DJ1E-0701084R01	SM25-060-90	DS-TP07S	-	-	DS-A00-.25-S	DT-08-.25	DS-TP07B1
1DJ1E-1001280R01	SM25-060-90	DS-TP07S	-	-	DS-A00-.25-S	DT-08-.25	DS-TP07B1
1DJ1E-1201581R01	SM25-060-90	DS-TP07S	-	-	DS-A00-.25-S	DT-08-.25	DS-TP07B1
1DJ1E-1201581R02	SM25-060-90	DS-TP07S	-	-	DS-A00-.25-S	DT-08-.25	DS-TP07B1
1DJ1E-1501786R01	SM25-060-90	DS-TP07S	-	-	DS-A00-.25-S	DT-08-.25	DS-TP07B1
1DJ1E-1501786R02	SM25-060-90	DS-TP07S	-	-	DS-A00-.25-S	DT-08-.25	DS-TP07B1
DJ5E-15R01	SM25-060-90	DS-TP07S	SD-04-47	-	DS-A00-.25-S	DT-08-.25	DS-TP07B1
DJ5E-20R01	SM25-060-90	DS-TP07S	SD-06-47	SD-06-A6	DS-A00-.25-S	DT-08-.25	DS-TP07B1
DJ6E-20R01	SM25-060-90	DS-TP07S	SD-06-47	SD-06-A6	DS-A00-.25-S	DT-08-.25	DS-TP07B1
DJ5E-25R01	SM25-060-90	DS-TP07S	SD-08-47	SD08-C9	DS-A00-.25-S	DT-08-.25	DS-TP07B1
DJ6E-25R01	SM25-060-90	DS-TP07S	SD-08-47	SD08-C9	DS-A00-.25-S	DT-08-.25	DS-TP07B1
DJ5E-30R01	SM25-060-90	DS-TP07S	SD-08-47	SD08-C9	DS-A00-.25-S	DT-08-.25	DS-TP07B1
DJ6E-30R01	SM25-060-90	DS-TP07S	SD-08-47	SD08-C9	DS-A00-.25-S	DT-08-.25	DS-TP07B1



DIPOSQUAD™ 12 SERIES DJ5G, DJ6G

90° FACE MILL (12MM INSERT)

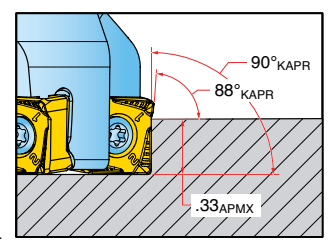
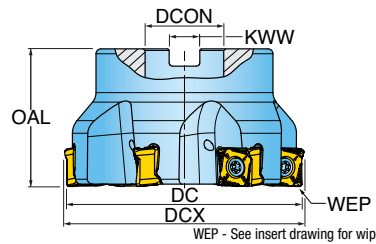
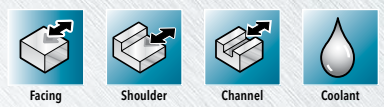

Part Number	DC Cutting Diameter	DCX Cutting Dia. Max.	OAL Overall Length	ZEFF Eff. Teeth	DCON Bore Dia.	KWW Keyway	CSP Coolant
DJ5G-20R01	2.000	2.055	1.570	6	0.750	0.312	Yes
DJ6G-20R01	2.000	2.055	1.570	4	0.750	0.312	Yes
DJ5G-25R01	2.500	2.555	1.570	8	1.000	0.375	Yes
DJ6G-25R01	2.500	2.555	1.570	5	1.000	0.375	Yes
DJ5G-30R01	3.000	3.051	1.750	11	1.000	0.375	Yes
DJ6G-30R01	3.000	3.051	1.750	6	1.000	0.375	Yes
DJ5G-40R01	4.000	4.051	2.375	14	1.500	0.625	Yes
DJ6G-40R01	4.000	4.051	2.375	8	1.500	0.625	Yes
DJ5G-50R01	5.000	5.052	2.375	18	1.500	0.625	Yes
DJ6G-50R01	5.000	5.052	2.375	10	1.500	0.625	Yes
DJ5G-60R01	6.000	6.051	2.000	22	2.000	0.750	No
DJ6G-60R01	6.000	6.051	2.000	12	2.000	0.750	No



DIPOSQUAD™ 12 INSERTS



SQXU12_M

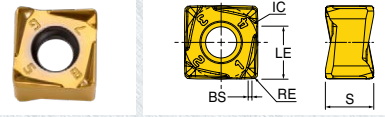

SQGU12_MM

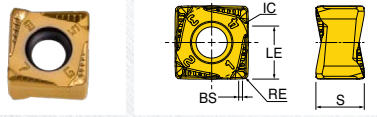

Part Number	Application	RE Corner Radius	BS Wiper Length	LE Cutting Edge Eff. Length	IC Inscribed Circle Dia.	S Thickness	NOI Number of Indexes	IH Insert Hand	Grade	IN6537	IN2505	IN2510	IN2504
SQXU120608R-M	Medium Roughing	0.031	0.043	0.330	0.480	0.319	8	Right		•	•	•	•
SQGU120608R-MM	Medium, pos. rake angle	0.031	0.043	0.330	0.480	0.319	8	Right			•	•	

DIPOSQUAD™ 12 HARDWARE

	Screw	Driver Handle	Torx Driver Blade	Retention Bolt	Coolant Retention Bolt	Torque Driver Handle	Preset Torque Bit	Torque Driver Bit
DJ5G-20R01	SM50-130-R0	DS-A00T	DS-T206B	SD-06-48	SD-06-89	DS-A00-.25-T	DT-44-.25	DS-T20B1
DJ6G-20R01	SM50-130-R0	DS-A00T	DS-T206B	SD-06-48	SD-06-89	DS-A00-.25-T	DT-44-.25	DS-T20B1
DJ5G-25R01	SM50-130-R0	DS-A00T	DS-T206B	SD-08-48	SD-08-92	DS-A00-.25-T	DT-44-.25	DS-T20B1
DJ6G-25R01	SM50-130-R0	DS-A00T	DS-T206B	SD-08-48	SD-08-92	DS-A00-.25-T	DT-44-.25	DS-T20B1
DJ5G-30R01	SM50-130-R0	DS-A00T	DS-T206B	SD-08-48	SD-08-92	DS-A00-.25-T	DT-44-.25	DS-T20B1
DJ6G-30R01	SM50-130-R0	DS-A00T	DS-T206B	SD-08-48	SD-08-92	DS-A00-.25-T	DT-44-.25	DS-T20B1
DJ5G-40R01	SM50-130-R0	DS-A00T	DS-T206B	SD-12-82	SD-12-99	DS-A00-.25-T	DT-44-.25	DS-T20B1
DJ6G-40R01	SM50-130-R0	DS-A00T	DS-T206B	SD-12-82	SD-12-99	DS-A00-.25-T	DT-44-.25	DS-T20B1
DJ5G-50R01	SM50-130-R0	DS-A00T	DS-T206B	SD-12-82	SD-12-99	DS-A00-.25-T	DT-44-.25	DS-T20B1
DJ6G-50R01	SM50-130-R0	DS-A00T	DS-T206B	SD-12-82	SD-12-99	DS-A00-.25-T	DT-44-.25	DS-T20B1
DJ5G-60R01	SM50-130-R0	DS-A00T	DS-T206B	SD-12-82	SD-12-99	DS-A00-.25-T	DT-44-.25	DS-T20B1
DJ6G-60R01	SM50-130-R0	DS-A00T	DS-T206B	SD-12-82	SD-12-99	DS-A00-.25-T	DT-44-.25	DS-T20B1

DIPOSQUAD™ 07 OPERATING GUIDELINES

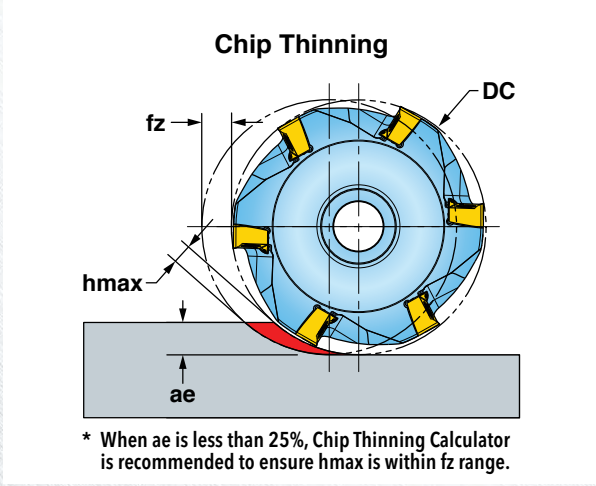

ISO	Materials			Vc Cutting Speed SFM	fz* Feed/Tooth (inch)	Harder Tougher			Coolant
	Mat'l Group #VDI 3323	Type	Examples			IN2510	IN2505	IN2530	
P	1 - 5	Non-alloy Steel	1018, A36, 1045, A572, 1070	400-1000	.003-.008				No
	6 - 9	Low-alloy Steel	4140, 4340, P20, 8620, 300M	350-700			2	1	
	10 - 11	High-alloy Steel	H13, A2, D2, M2, T1	300-600					
M	12 - 13	Stainless Steel (ferritic & martensitic)	410, 416, 440	350-600	.003-.006		2	1	Yes
	14	Stainless Steel (austenitic)	303, 304, 316, 15-5, 17-4	300-550					May not be required at high speeds
K	15 - 16	Gray Cast Iron	CLS. 20, 30, 45	500-1000	.003-.008	1	2		No
	17 - 18	Nodular Cast Iron	60-40-18, 100-70-03	400-800					
S	31 - 35	High-Temp Alloys	Inconel, Hastelloy, Nimonic, Monel	65-120	.003-.006		1	2	Yes
	36 - 37	Titanium Alloys	6Al-4V, 5Al-5Mo-5V-3Cr	85-130			2	1	

Note: Feed and speed recommendations are starting operating parameters. They are only guidelines from which further optimization should take place. Operating parameters are influenced by many machining variables. These variables may cause for reductions in feeds and speed or dramatic increases. Additionally, DOC and WOC may need to be revised to optimize the tools performance.

DIPOSQUAD™ 12 OPERATING GUIDELINES

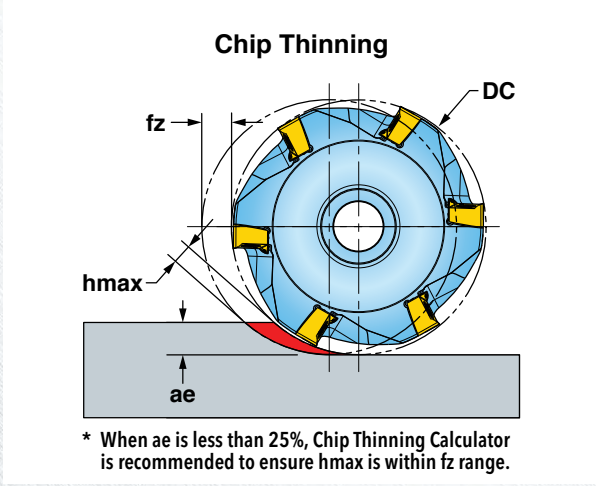

ISO	Materials			Vc Cutting Speed SFM	fz* Feed/Tooth (inch)	Harder Tougher				Coolant
	Mat'l Group #VDI 3323	Type	Examples			IN2504	IN2510	IN2505	IN6537	
P	1 thru 5	Non-alloy Steel	1018, A36, 1045, A572, 1070	400-1000	.003-.010					No
	6 thru 9	Low-alloy Steel	4140, 4340, P20, 8620, 300M	350-700				2	1	
	10, 11	High-alloy Steel	H13, A2, D2, M2, T1	300-600						
K	15 thru 16	Gray Cast Iron	CLS. 20, 30, 45	500-1000	.003-.010	2	1	3		No
	17 thru 20	Nodular Cast Iron	60-40-18, 100-70-03	400-800						
H	38 thru 39	Hardened Steel >48	A2, O1, D2	130-250	.003-.005	1				No

Note: Feed and speed recommendations are starting operating parameters. They are only guidelines from which further optimization should take place. Operating parameters are influenced by many machining variables. These variables may cause for reductions in feeds and speed or dramatic increases. Additionally, DOC and WOC may need to be revised to optimize the tools performance.