

MILLING - INDEXABLE

Cutter Series (Depth of Cut)

1DJ1E / DJ5E / DJ6E (.19)

1DJ1R / DJ5R / DJ6R (.27)

DJ5G / DJ6G (.33)

NEW

Insert Series

SQGU07, **SQGU10**,
SQGU12 / SQXU12

NEW

Diameter Range

0.625-6.000" (16-50 mm)

Lead Angles

90°

Corner Radius

0.031"

Materials

- Steel
- Stainless Steel
- Cast Iron/Iron
- High-Temp Alloys/Titanium
- Hardened Steel

DIPOSQUAD™

True 90° Shoulder Mills with 8-Edge Economy

- » Integrated wiper flats produce 32-63 Ra finishes.
- » Minimal mismatch when stepping down a wall (7 and 10 mm only).
- » High axial rake reduces cutting loads and promotes smooth machining.



12 mm



10 mm



7 mm

NEW



See it in action! »



WINSPEED™
ADVANCED MACHINING

Fig. A
 7/10 mm



Fig. B
 10/12 mm

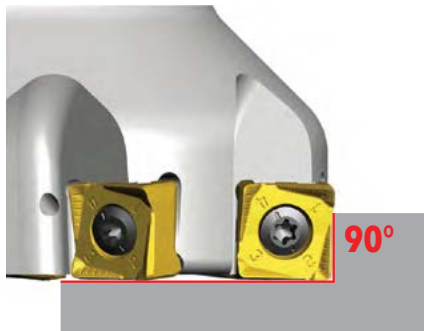

Fig. C
 10/12 mm



Fig. D



Overview

Ingersoll's new **DiPosQuad** line utilizes 2-side-technology to offer economical 8-corner inserts that generate true 90° shoulders and smooth surface finishes. Medium and fine pitch cutter offerings compliment the geometry for premium performance, and unequally spaced insert placement aids to diffuse vibration.

INSERT FEATURES & BENEFITS:

- 7 and 10 mm offer inserts that generate true 90° and are optimized to step down axially with minimal mismatch (**Fig. A**).
- 10 and 12 mm offer inserts that generate true 90° up to the integrated wiper (**Fig. B**). Beyond that point, insert clearance is insufficient to step down the wall without mismatch (**Fig. C**).
- Improved surface finish via the insert's wiper edge (**Fig. D**).
- Insert's reinforced cutting edge enhances machining stability (**Fig. E**).

Fig. E

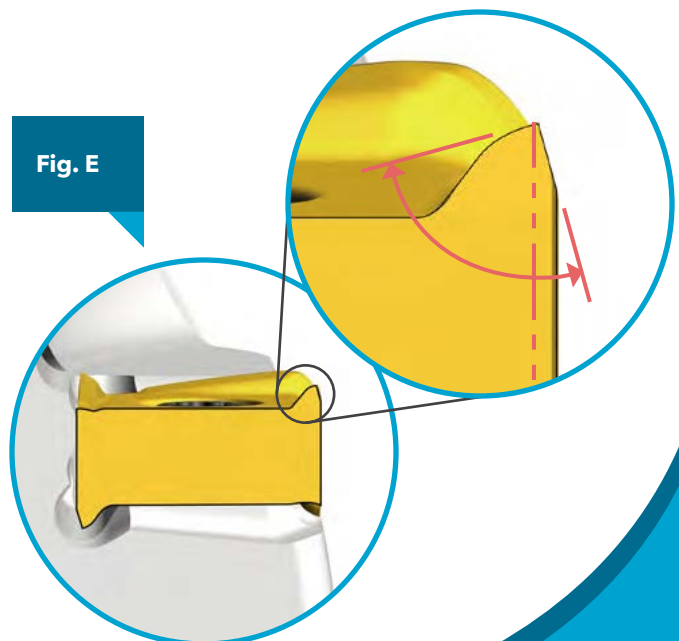

7 mm • Series 1DJ1E

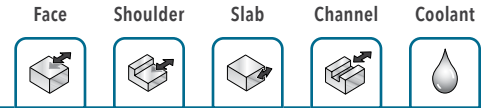

90° ROUGH/FINISH END MILL - WELDON (7 MM INSERT)

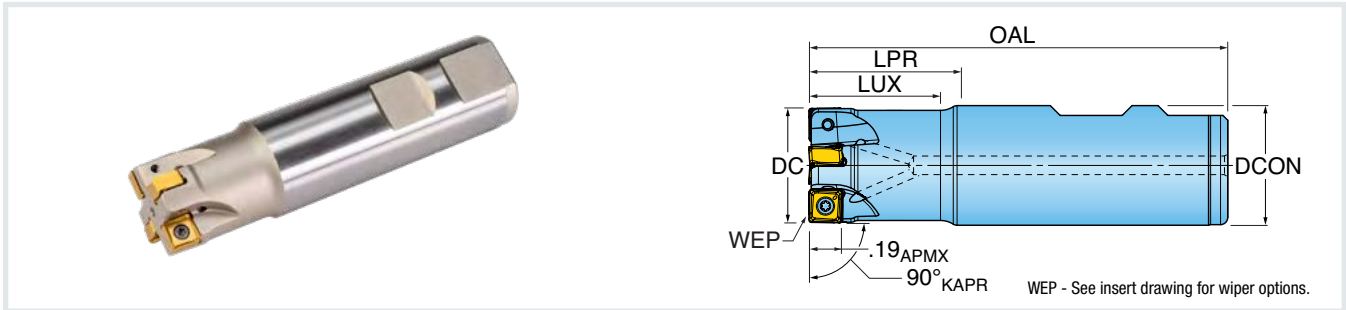

Part Number	DC Cutting Dia.	LUX Usable Length Max.	LPR Protruding Length	OAL Overall Length	ZEFF Eff. Teeth	DCON Shank Dia.
INCH						
1DJ1E-0600779R01	0.625	0.70	0.75	2.66	2	0.6250
1DJ1E-0701084R01	0.750	0.95	1.00	3.00	3	0.7500
1DJ1E-1001280R01	1.000	1.20	1.25	3.50	4	1.0000
1DJ1E-1201581R01	1.250	1.45	1.50	3.75	4	1.2500
1DJ1E-1201581R02	1.250	1.45	1.50	3.75	6	1.2500
1DJ1E-1501786R01	1.500	1.70	1.75	4.41	5	1.5000
1DJ1E-1501786R02	1.500	1.70	1.75	4.41	8	1.5000
METRIC						
1DJ1E016020W3R00	16.00 mm	20.0 mm	23.0 mm	90.0 mm	2	16.00 mm
1DJ1E020025W4R00	20.00 mm	25.0 mm	28.0 mm	90.0 mm	3	20.00 mm
1DJ1E025030W5R00	25.00 mm	30.0 mm	33.0 mm	100.0 mm	4	25.00 mm
1DJ1E032035W6R00	32.00 mm	35.0 mm	38.0 mm	110.0 mm	6	32.00 mm

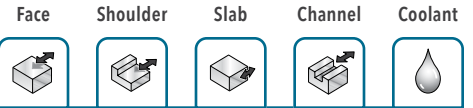

7 mm • Series 1DJ1E

90° ROUGH/FINISH END MILL - TOPON (7 MM INSERT)

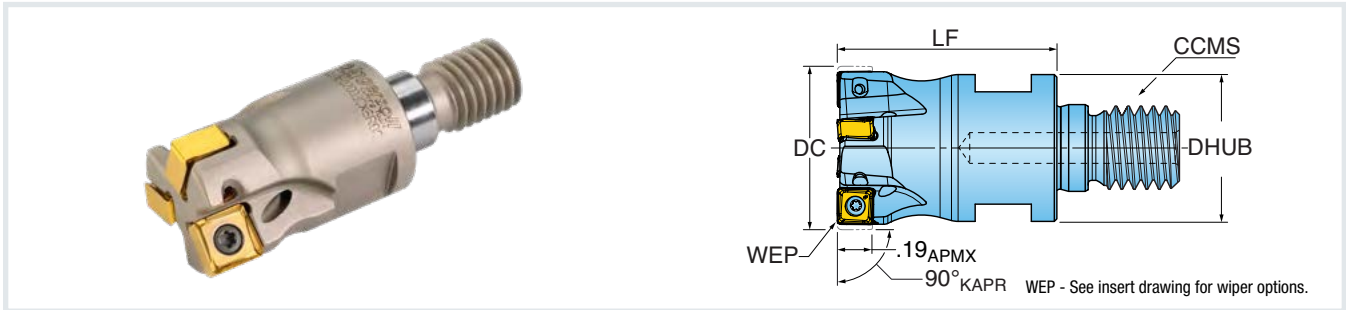

Part Number	DC Cutting Dia.	LF Functional Length	ZEFF Eff. Teeth	CCMS Connection Code Machine Side	DHUB Hub Dia.
METRIC					
1DJ1E016023X5R00	16.00 mm	23.0 mm	2	TopOn M08	13.0 mm
1DJ1E020030X6R00	20.00 mm	30.0 mm	3	TopOn M10	18.0 mm
1DJ1E025035X7R00	25.00 mm	35.0 mm	3	TopOn M12	21.0 mm
1DJ1E032043X8R00	32.00 mm	43.0 mm	4	TopOn M16	29.0 mm
1DJ1E040043X8R00	40.00 mm	43.0 mm	5	TopOn M16	29.0 mm

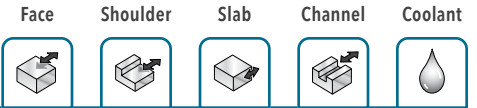

7 mm • Series DJ5E, DJ6E

90° ROUGH/FINISH FACE MILL (7 MM INSERT)

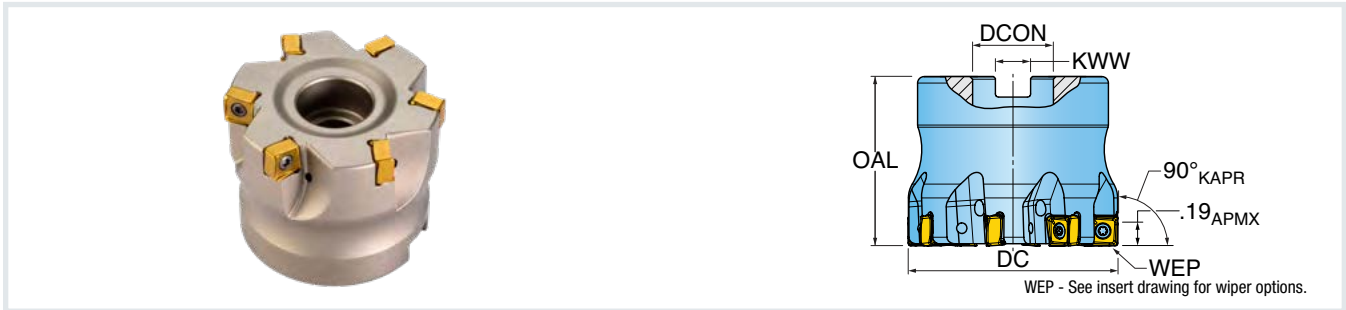

Part Number	DC Cutting Dia.	OAL Overall Length	ZEFF Eff. Teeth	DCON Bore Dia.	KWW Keyway
INCH					
DJ5E-15R01	1.500	1.570	6	0.5000	0.250
DJ5E-20R01	2.000	1.570	8	0.7500	0.312
DJ6E-20R01	2.000	1.570	6	0.7500	0.312
DJ5E-25R01	2.500	1.570	10	1.0000	0.375
DJ6E-25R01	2.500	1.570	7	1.0000	0.375
DJ5E-30R01	3.000	1.750	12	1.0000	0.375
DJ6E-30R01	3.000	1.750	8	1.0000	0.375
METRIC					
DJ5E032R00	32.00 mm	32.00 mm	4	16.00 mm	8.40 mm
DJ5E040R00	40.00 mm	40.00 mm	6	16.00 mm	8.40 mm
DJ5E050R00	50.00 mm	40.00 mm	8	22.00 mm	10.40 mm

7 mm • Inserts

SQGU07_M

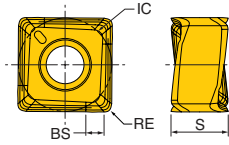
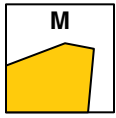

90°

Multi-step capable

SQGU07_ML

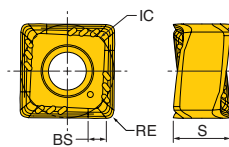







90°

Multi-step capable

Part Number	Application	RE Corner Radius	BS Wiper Length	IC Inscribed Circle Dia.	S Thickness	NOI Number of Indexes	IH Insert Hand	Grade			
								IN2504	IN2505	IN2510	IN2530
SQGU070408TR-M	Multi-purpose, full shoulder	0.031	0.035	0.275	0.165	8	Right	•	•	•	•
SQGU070408TR-ML	High-positive, full shoulder	0.031	0.035	0.275	0.163	8	Right		•	•	•

7 mm • Hardware

				Optional			
	 Screw	 Torx Screwdriver	 Retention Bolt	 Coolant Retention Bolt	 Torque Driver Handle	 Preset Torque Bit	 Torque Driver Bit
INCH							
1DJ1E-0600779R01	SM25-060-90	DS-TP07S	-	-	DS-A00-.25-S	DT-08-.25	DS-TP07B
1DJ1E-0701084R01	SM25-060-90	DS-TP07S	-	-	DS-A00-.25-S	DT-08-.25	DS-TP07B
1DJ1E-1001280R01	SM25-060-90	DS-TP07S	-	-	DS-A00-.25-S	DT-08-.25	DS-TP07B
1DJ1E-1201581R01	SM25-060-90	DS-TP07S	-	-	DS-A00-.25-S	DT-08-.25	DS-TP07B
1DJ1E-1201581R02	SM25-060-90	DS-TP07S	-	-	DS-A00-.25-S	DT-08-.25	DS-TP07B
1DJ1E-1501786R01	SM25-060-90	DS-TP07S	-	-	DS-A00-.25-S	DT-08-.25	DS-TP07B
1DJ1E-1501786R02	SM25-060-90	DS-TP07S	-	-	DS-A00-.25-S	DT-08-.25	DS-TP07B
DJ5E-15R01	SM25-060-90	DS-TP07S	SD-04-47	-	DS-A00-.25-S	DT-08-.25	DS-TP07B
DJ5E-20R01	SM25-060-90	DS-TP07S	SD-06-47	SD-06-A6	DS-A00-.25-S	DT-08-.25	DS-TP07B
DJ6E-20R01	SM25-060-90	DS-TP07S	SD-06-47	SD-06-A6	DS-A00-.25-S	DT-08-.25	DS-TP07B
DJ5E-25R01	SM25-060-90	DS-TP07S	SD-08-47	SD08-C9	DS-A00-.25-S	DT-08-.25	DS-TP07B
DJ6E-25R01	SM25-060-90	DS-TP07S	SD-08-47	SD08-C9	DS-A00-.25-S	DT-08-.25	DS-TP07B
DJ5E-30R01	SM25-060-90	DS-TP07S	SD-08-47	SD08-C9	DS-A00-.25-S	DT-08-.25	DS-TP07B
DJ6E-30R01	SM25-060-90	DS-TP07S	SD-08-47	SD08-C9	DS-A00-.25-S	DT-08-.25	DS-TP07B
METRIC							
1DJ1E016020W3R00	SM25-060-90	DS-TP07S	-	-	DS-A00-.25-S	DT-08-.25	DS-TP07B
1DJ1E020025W4R00	SM25-060-90	DS-TP07S	-	-	DS-A00-.25-S	DT-08-.25	DS-TP07B
1DJ1E025030W5R00	SM25-060-90	DS-TP07S	-	-	DS-A00-.25-S	DT-08-.25	DS-TP07B
1DJ1E032035W6R00	SM25-060-90	DS-TP07S	-	-	DS-A00-.25-S	DT-08-.25	DS-TP07B
1DJ1E016023X5R00	SM25-060-90	DS-TP07S	-	-	DS-A00-.25-S	DT-08-.25	DS-TP07B
1DJ1E020030X6R00	SM25-060-90	DS-TP07S	-	-	DS-A00-.25-S	DT-08-.25	DS-TP07B
1DJ1E025035X7R00	SM25-060-90	DS-TP07S	-	-	DS-A00-.25-S	DT-08-.25	DS-TP07B
1DJ1E032043X8R00	SM25-060-90	DS-TP07S	-	-	DS-A00-.25-S	DT-08-.25	DS-TP07B
1DJ1E040043X8R00	SM25-060-90	DS-TP07S	-	-	DS-A00-.25-S	DT-08-.25	DS-TP07B
DJ5E032R00	SM25-060-90	DS-TP07S	ISO4762M8X20-12.9	-	DS-A00-.25-S	DT-08-.25	DS-TP07B
DJ5E040R00	SM25-060-90	DS-TP07S	ISO4762M8X30-12.9	-	DS-A00-.25-S	DT-08-.25	DS-TP07B
DJ5E050R00	SM25-060-90	DS-TP07S	ISO4762M10X25-12.9	-	DS-A00-.25-S	DT-08-.25	DS-TP07B

10 mm • Series 1DJ1R **NEW**

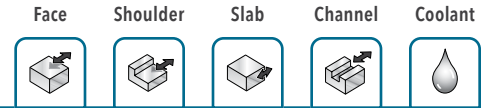

90° ROUGH/FINISH END MILL - WELDON (10 MM INSERT)

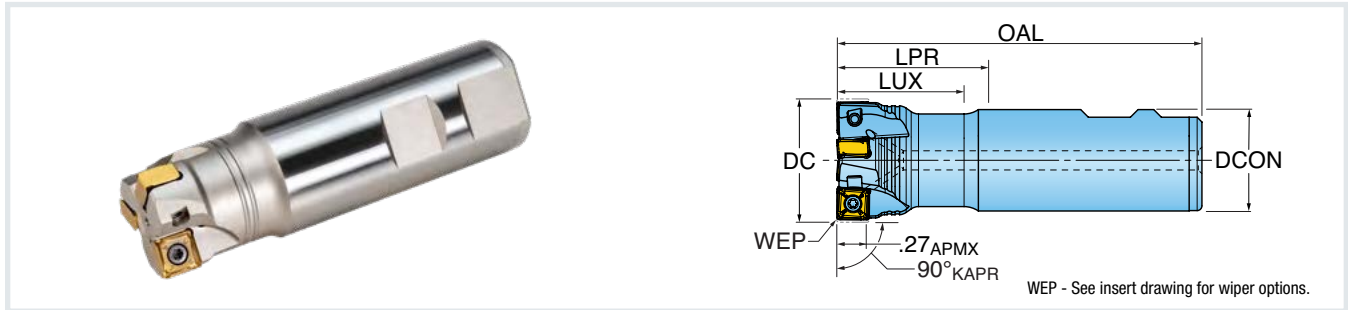

Part Number	DC Cutting Dia.	LUX Usable Length Max.	LPR Protruding Length	OAL Overall Length	ZEFF Eff. Teeth	DCON Shank Dia.
INCH						
1DJ1R-1001780R01	1.000	1.63	1.75	4.00	2	1.0000
1DJ1R-1202281R01	1.250	2.13	2.25	4.50	3	1.2500
1DJ1R-1502281R01	1.500	2.25	2.25	4.50	4	1.2500
METRIC						
1DJ1R025030W5R00	25.00 mm	30.0 mm	44.1 mm	100.0 mm	2	25.00 mm
1DJ1R032035W6R00	32.00 mm	35.0 mm	50.1 mm	110.0 mm	3	32.00 mm
1DJ1R040040W6R00	40.00 mm	40.0 mm	50.1 mm	110.0 mm	4	32.00 mm

10 mm • Series 1DJ1R **NEW**

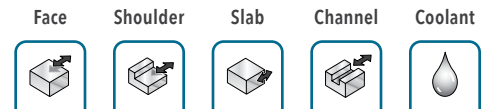

90° ROUGH/FINISH END MILL - CYLINDRICAL (10 MM INSERT)

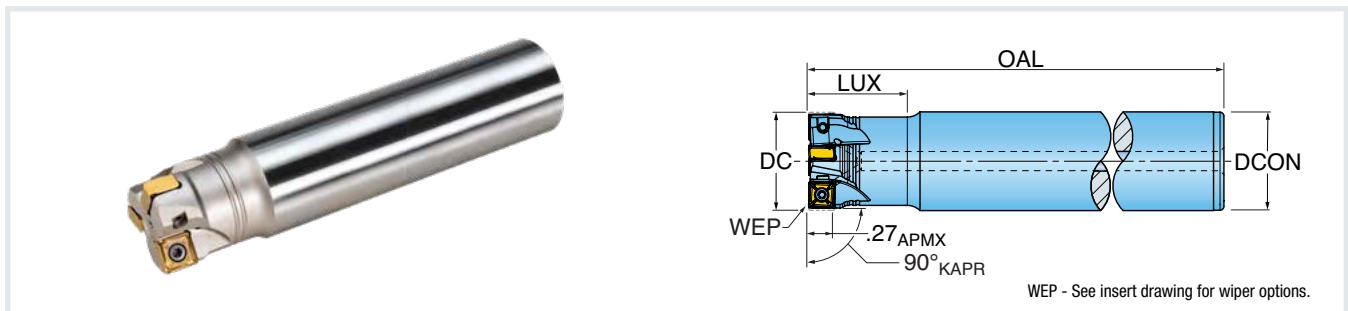

Part Number	DC Cutting Dia.	LUX Usable Length Max.	OAL Overall Length	ZEFF Eff. Teeth	DCON Shank Dia.
INCH					
1DJ1R-1001251R01	1.000	1.40	6.00	2	1.0000
1DJ1R-1201559R01	1.250	1.70	7.00	3	1.2500
1DJ1R-1501555R01	1.500	1.70	8.00	4	1.5000

Designed with modification in mind. Extend usable length by turning back the neck diameter or shorten the overall length by cutting off back end.

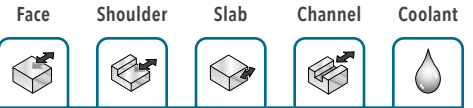

10 mm • Series 1DJ1R **NEW**

90° ROUGH/FINISH END MILL - TOPON (10 MM INSERT)

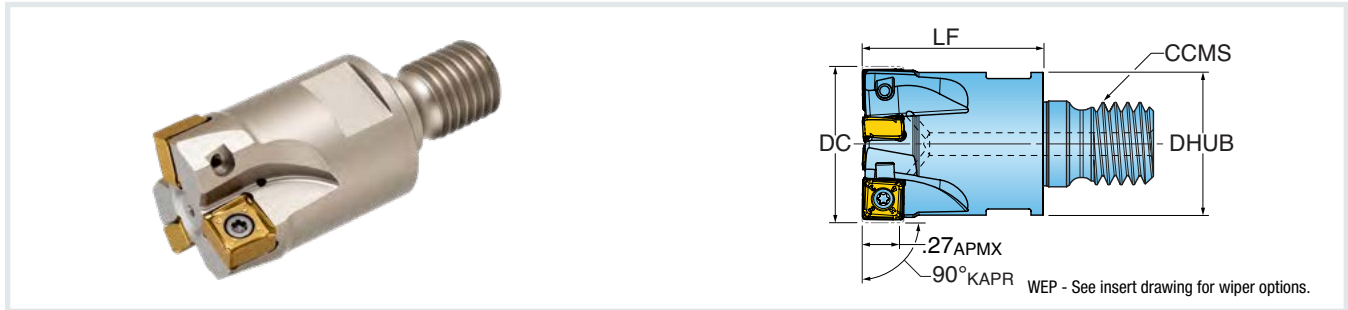

Part Number	DC Cutting Dia.	LF Functional Length	ZEFF Eff. Teeth	CCMS Connection Code Machine Side	DHUB Hub Dia.
INCH					
1DJ1R-10015X7R01	1.000	1.50	2	TopOn M12	0.82
1DJ1R-12017X8R01	1.250	1.75	3	TopOn M16	1.14
1DJ1R-15017X9R01	1.500	1.75	4	TopOn M20	1.37
METRIC					
1DJ1R025035X7R00	25.00 mm	35.0 mm	2	TopOn M12	22.0 mm
1DJ1R032043X8R00	32.00 mm	43.0 mm	3	TopOn M16	29.0 mm
1DJ1R040043X8R00	40.00 mm	43.0 mm	4	TopOn M16	29.0 mm

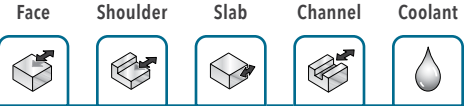

10 mm • Series DJ5R, DJ6R **NEW**

90° ROUGH/FINISH FACE MILL (10 MM INSERT)

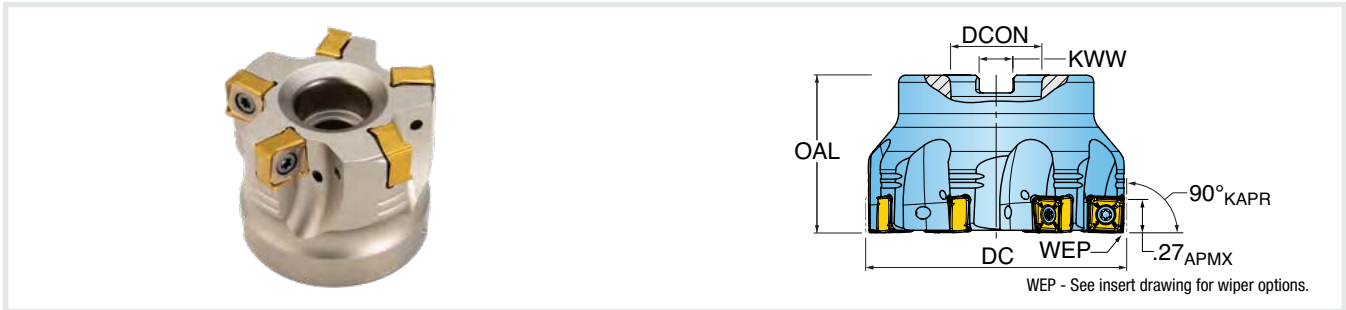

Part Number	DC Cutting Dia.	OAL Overall Length	ZEFF Eff. Teeth	DCON Bore Dia.	KWW Keyway
INCH					
DJ6R-15R01	1.500	1.570	4	0.5000	0.250
DJ6R-20R01	2.000	1.570	5	0.7500	0.312
DJ6R-25R01	2.500	1.570	6	1.0000	0.375
DJ5R-25R01	2.500	1.570	8	1.0000	0.375
DJ6R-30R01	3.000	1.750	8	1.0000	0.375
DJ5R-30R01	3.000	1.750	10	1.0000	0.375
DJ6R-40R01	4.000	2.375	10	1.5000	0.625
DJ5R-40R01	4.000	2.375	14	1.5000	0.625
DJ6R-50R01	5.000	2.375	12	1.5000	0.625
DJ5R-50R01	5.000	2.375	16	1.5000	0.625
METRIC					
DJ5R040R00	40.00 mm	40.00 mm	4	16.00 mm	8.40 mm
DJ6R050R00	50.00 mm	40.00 mm	5	22.00 mm	10.40 mm
DJ6R063R00	63.00 mm	40.00 mm	6	22.00 mm	10.40 mm
DJ5R063R00	63.00 mm	40.00 mm	8	22.00 mm	10.40 mm
DJ6R080R00	80.00 mm	50.00 mm	8	27.00 mm	12.40 mm
DJ5R080R00	80.00 mm	50.00 mm	10	27.00 mm	12.40 mm
DJ6R100R00	100.00 mm	50.00 mm	10	32.00 mm	14.40 mm
DJ5R100R00	100.00 mm	50.00 mm	14	32.00 mm	14.40 mm
DJ6R125R00	125.00 mm	63.00 mm	12	40.00 mm	16.40 mm
DJ5R125R00	125.00 mm	63.00 mm	16	40.00 mm	16.40 mm

10 mm • Inserts **NEW**

SQGU10_M

Multi-step capable

SQGU10_MP









Not multi-step capable

SQGU10_MMP

Not multi-step capable

Part Number	Application	RE Corner Radius	BS Wiper Length	LE Cutting Edge Eff. Length	IC Inscribed Circle Dia.	S Thickness	NOI Number of Indexes	IH Insert Hand	Grade			
									IN2504	IN2505	IN2510	IN2530
SQGU100408TR-M	Multi-purpose, full shoulder	0.031	0.043	0.270	0.394	0.228	8	Right	•	•		•
SQGU100408PNR-MP	Positive, partial shoulder	0.031	0.043	0.270	0.394	0.228	8	Right		•	•	
SQGU100408PNR-MMP	High positive, partial shoulder	0.031	0.043	0.270	0.394	0.228	8	Right			•	

10 mm • Hardware

Part Number					Optional			
								
	Screw	Driver Handle	Torx Driver Blade	Retention Bolt	Coolant Retention Bolt	Torque Driver Handle	Preset Torque Adapter	Torque Driver Bit
INCH								
1DJ1R-1001780R01	SM35-088-10	DS-A00T	DS-T106B	-	-	DS-A00-.25-T	DT-30-.25	DS-T10B1
1DJ1R-1202281R01	SM35-088-10	DS-A00T	DS-T106B	-	-	DS-A00-.25-T	DT-30-.25	DS-T10B1
1DJ1R-1502281R01	SM35-088-10	DS-A00T	DS-T106B	-	-	DS-A00-.25-T	DT-30-.25	DS-T10B1
1DJ1R-1001251R01	SM35-088-10	DS-A00T	DS-T106B	-	-	DS-A00-.25-T	DT-30-.25	DS-T10B1
1DJ1R-1201559R01	SM35-088-10	DS-A00T	DS-T106B	-	-	DS-A00-.25-T	DT-30-.25	DS-T10B1
1DJ1R-1501555R01	SM35-088-10	DS-A00T	DS-T106B	-	-	DS-A00-.25-T	DT-30-.25	DS-T10B1
1DJ1R-10015X7R01	SM35-088-10	DS-A00T	DS-T106B	-	-	DS-A00-.25-T	DT-30-.25	DS-T10B1
1DJ1R-12017X8R01	SM35-088-10	DS-A00T	DS-T106B	-	-	DS-A00-.25-T	DT-30-.25	DS-T10B1
1DJ1R-15017X9R01	SM35-088-10	DS-A00T	DS-T106B	-	-	DS-A00-.25-T	DT-30-.25	DS-T10B1
DJ6R-15R01	SM35-088-10	DS-A00T	DS-T106B	SD-04-47	-	DS-A00-.25-T	DT-30-.25	DS-T10B1
DJ6R-20R01	SM35-088-10	DS-A00T	DS-T106B	SD-06-46	SD-06-89	DS-A00-.25-T	DT-30-.25	DS-T10B1
DJ6R-25R01	SM35-088-10	DS-A00T	DS-T106B	SD-08-47	SD-08-C9	DS-A00-.25-T	DT-30-.25	DS-T10B1
DJ5R-25R01	SM35-088-10	DS-A00T	DS-T106B	SD-08-47	SD-08-C9	DS-A00-.25-T	DT-30-.25	DS-T10B1
DJ6R-30R01	SM35-088-10	DS-A00T	DS-T106B	SD-08-47	SD-08-C9	DS-A00-.25-T	DT-30-.25	DS-T10B1
DJ5R-30R01	SM35-088-10	DS-A00T	DS-T106B	SD-08-47	SD-08-C9	DS-A00-.25-T	DT-30-.25	DS-T10B1
DJ6R-40R01	SM35-088-10	DS-A00T	DS-T106B	SD-12-82	SD-12-99	DS-A00-.25-T	DT-30-.25	DS-T10B1
DJ5R-40R01	SM35-088-10	DS-A00T	DS-T106B	SD-12-82	SD-12-99	DS-A00-.25-T	DT-30-.25	DS-T10B1
DJ6R-50R01	SM35-088-10	DS-A00T	DS-T106B	SD-12-82	SD-12-99	DS-A00-.25-T	DT-30-.25	DS-T10B1
DJ5R-50R01	SM35-088-10	DS-A00T	DS-T106B	SD-12-82	SD-12-99	DS-A00-.25-T	DT-30-.25	DS-T10B1
METRIC								
1DJ1R025030W5R00	SM35-088-10	DS-A00T	DS-T106B	-	-	DS-A00-.25-T	DT-30-.25	DS-T10B1
1DJ1R032035W6R00	SM35-088-10	DS-A00T	DS-T106B	-	-	DS-A00-.25-T	DT-30-.25	DS-T10B1
1DJ1R040040W6R00	SM35-088-10	DS-A00T	DS-T106B	-	-	DS-A00-.25-T	DT-30-.25	DS-T10B1
1DJ1R025035X7R00	SM35-088-10	DS-A00T	DS-T106B	-	-	DS-A00-.25-T	DT-30-.25	DS-T10B1
1DJ1R032043X8R00	SM35-088-10	DS-A00T	DS-T106B	-	-	DS-A00-.25-T	DT-30-.25	DS-T10B1
1DJ1R040043X8R00	SM35-088-10	DS-A00T	DS-T106B	-	-	DS-A00-.25-T	DT-30-.25	DS-T10B1
DJ5R040R00	SM35-088-10	DS-A00T	DS-T106B	SHM8X1.25X25	SHM8X1.25X25-C	DS-A00-.25-T	DT-30-.25	DS-T10B1
DJ6R050R00	SM35-088-10	DS-A00T	DS-T106B	SHM10X1.5X30	SHM10X1.5X30-C	DS-A00-.25-T	DT-30-.25	DS-T10B1
DJ6R063R00	SM35-088-10	DS-A00T	DS-T106B	SHM10X1.5X30	SHM10X1.5X30-C	DS-A00-.25-T	DT-30-.25	DS-T10B1
DJ5R063R00	SM35-088-10	DS-A00T	DS-T106B	SHM10X1.5X30	SHM10X1.5X30-C	DS-A00-.25-T	DT-30-.25	DS-T10B1
DJ6R080R00	SM35-088-10	DS-A00T	DS-T106B	SHM12X1.75X35	SHM12X1.75X35-C	DS-A00-.25-T	DT-30-.25	DS-T10B1
DJ5R080R00	SM35-088-10	DS-A00T	DS-T106B	SHM12X1.75X35	SHM12X1.75X35-C	DS-A00-.25-T	DT-30-.25	DS-T10B1
DJ6R100R00	SM35-088-10	DS-A00T	DS-T106B	SHM16X2X35	SHM16X2X35-C	DS-A00-.25-T	DT-30-.25	DS-T10B1
DJ5R100R00	SM35-088-10	DS-A00T	DS-T106B	SHM16X2X35	SHM16X2X35-C	DS-A00-.25-T	DT-30-.25	DS-T10B1
DJ6R125R00	SM35-088-10	DS-A00T	DS-T106B	SHM20X2.5X40	SHM20X2.5X40-C	DS-A00-.25-T	DT-30-.25	DS-T10B1
DJ5R125R00	SM35-088-10	DS-A00T	DS-T106B	SHM20X2.5X40	SHM20X2.5X40-C	DS-A00-.25-T	DT-30-.25	DS-T10B1

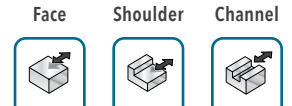

12 mm • Series DJ5G, DJ6G

90° FACE MILL (12 MM INSERT)

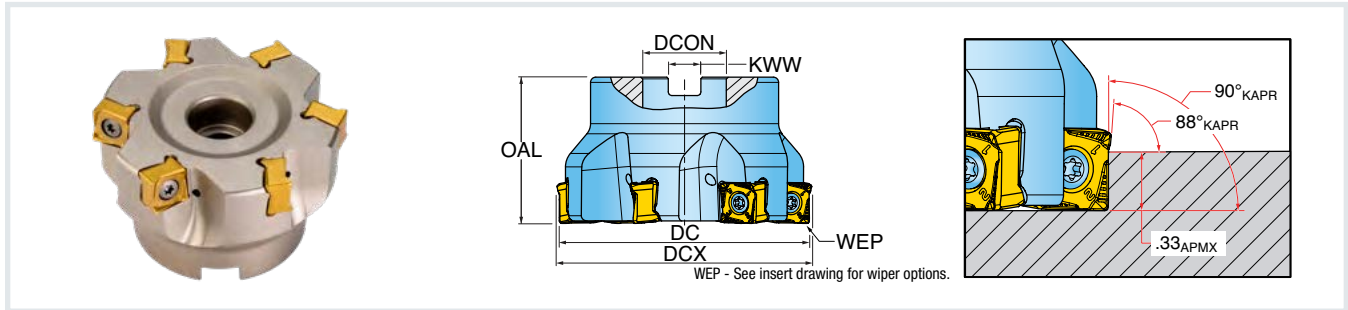

Part Number	DC Cutting Dia.	DCX Cutting Dia. Max.	OAL Overall Length	ZEFF Eff. Teeth	DCON Bore Dia.	KWW Keyway	CSP Coolant
INCH							
DJ5G-20R01	2.000	2.055	1.570	6	0.7500	0.312	Yes
DJ6G-20R01	2.000	2.055	1.570	4	0.7500	0.312	Yes
DJ5G-25R01	2.500	2.555	1.570	8	1.0000	0.375	Yes
DJ6G-25R01	2.500	2.555	1.570	5	1.0000	0.375	Yes
DJ5G-30R01	3.000	3.051	1.750	11	1.0000	0.375	Yes
DJ6G-30R01	3.000	3.051	1.750	6	1.0000	0.375	Yes
DJ5G-40R01	4.000	4.051	2.375	14	1.5000	0.625	Yes
DJ6G-40R01	4.000	4.051	2.375	8	1.5000	0.625	Yes
DJ5G-50R01	5.000	5.052	2.375	18	1.5000	0.625	Yes
DJ6G-50R01	5.000	5.052	2.375	10	1.5000	0.625	Yes
DJ5G-60R01	6.000	6.051	2.000	22	2.0000	0.750	No
DJ6G-60R01	6.000	6.051	2.000	12	2.0000	0.750	No

12 mm • Inserts

SQXU12_M

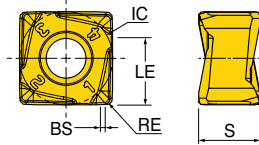
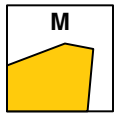

Not multi-step capable



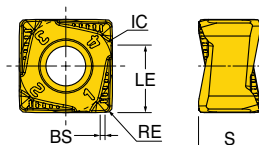





SQGU12_MM



Not multi-step capable

Part Number	Application	RE Corner Radius	BS Wiper Length	LE Cutting Edge Eff. Length	IC Inscribed Circle Dia.	S Thickness	NOI Number of Indexes	IH Insert Hand	Grade			
									IN6537	IN2505	IN2510	IN2504
SQXU120608R-M	Positive, partial shoulder	0.031	0.043	0.330	0.480	0.319	8	Right	•	•	•	•
SQGU120608R-MM	High positive, partial shoulder	0.031	0.043	0.330	0.480	0.319	8	Right		•	•	

12 mm • Hardware

Part Number	Optional							
								
INCH								
DJ5G-20R01	SM40-100-R0	DS-A00T	DS-T156B	SD-06-48	SD-06-89	DS-A00-.25-T	DT-35-.25	DS-T15B1
DJ6G-20R01	SM40-100-R0	DS-A00T	DS-T156B	SD-06-48	SD-06-89	DS-A00-.25-T	DT-35-.25	DS-T15B1
DJ5G-25R01	SM40-100-R0	DS-A00T	DS-T156B	SD-08-48	SD-08-92	DS-A00-.25-T	DT-35-.25	DS-T15B1
DJ6G-25R01	SM40-100-R0	DS-A00T	DS-T156B	SD-08-48	SD-08-92	DS-A00-.25-T	DT-35-.25	DS-T15B1
DJ5G-30R01	SM40-100-R0	DS-A00T	DS-T156B	SD-08-48	SD-08-92	DS-A00-.25-T	DT-35-.25	DS-T15B1
DJ6G-30R01	SM40-100-R0	DS-A00T	DS-T156B	SD-08-48	SD-08-92	DS-A00-.25-T	DT-35-.25	DS-T15B1
DJ5G-40R01	SM40-100-R0	DS-A00T	DS-T156B	SD-12-82	SD-12-99	DS-A00-.25-T	DT-35-.25	DS-T15B1
DJ6G-40R01	SM40-100-R0	DS-A00T	DS-T156B	SD-12-82	SD-12-99	DS-A00-.25-T	DT-35-.25	DS-T15B1
DJ5G-50R01	SM40-100-R0	DS-A00T	DS-T156B	SD-12-82	SD-12-99	DS-A00-.25-T	DT-35-.25	DS-T15B1
DJ6G-50R01	SM40-100-R0	DS-A00T	DS-T156B	SD-12-82	SD-12-99	DS-A00-.25-T	DT-35-.25	DS-T15B1
DJ5G-60R01	SM40-100-R0	DS-A00T	DS-T156B	SD-12-82	SD-12-99	DS-A00-.25-T	DT-35-.25	DS-T15B1
DJ6G-60R01	SM40-100-R0	DS-A00T	DS-T156B	SD-12-82	SD-12-99	DS-A00-.25-T	DT-35-.25	DS-T15B1

7 mm • Operating Guidelines

CHIP THINNING

When a_e is less than 25%,
Chip Thinning Calculator
is recommended to ensure
 h_{max} is within f_z range. ▶

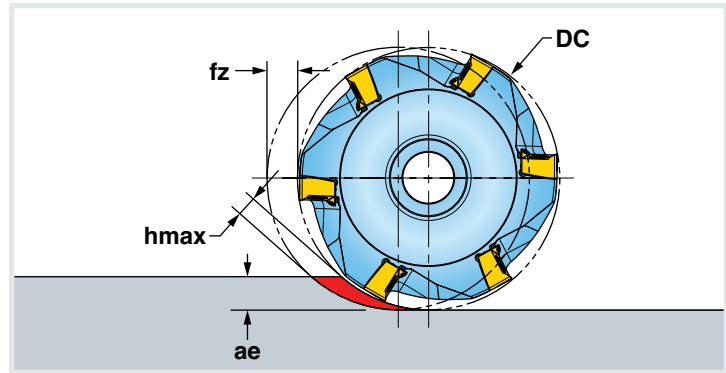

ISO	Material Group #VDI 3323	Type	Examples	Vc Cutting Speed SFM	fz* Feed/Tooth (inch)	Harder «----» Tougher				Coolant
						IN2504	IN2510	IN2505	IN2530	
P	1-5	Non-Alloy Steel	1018, A36, 1045, A572, 1070	400-1000	.003-.008	3	-	2	1	No
	6-9	Low-Alloy Steel	4140, 4340, P20, 8620, 300M	350-700						
	10-11	High-Alloy Steel	H13, A2, D2, M2, T1	300-600						
M	12-13	Stainless Steel (ferritic & martensitic)	410, 416, 440	350-600	.003-.006	-	-	2	1	No
	14	Stainless Steel (austenitic)	303, 304, 316, 15-5, 17-4	300-550						May not be required at high speeds
K	15-16	Gray Cast Iron	CLS. 20, 30, 45	500-1000	.003-.008	2	1	-	-	No
	17-18	Nodular Cast Iron	60-40-18, 100-70-03	400-800						
S	31-35	High-Temp Alloys	Inconel, Hastelloy, Nimonic, Monel	65-120	.003-.006	-	-	1	2	Yes
	36-37	Titanium Alloys	6Al-4V, 5Al-5Mo-5V-3Cr	85-130						
H	38-39	Hardened Steel > 48	A2, 01, D2	130-250	.003-.005	1	-	-	-	No

Note: Feed and speed recommendations are starting operating parameters. They are only guidelines from which further optimization should take place. Operating parameters are influenced by many machining variables. These variables may cause for reductions in feeds and speed or dramatic increases. Additionally, DOC and WOC may need to be revised to optimize the tools performance.

10 mm • Operating Guidelines

CHIP THINNING

When ae is less than 25%,
Chip Thinning Calculator
 is recommended to ensure
 h_{max} is within fz range. ▶

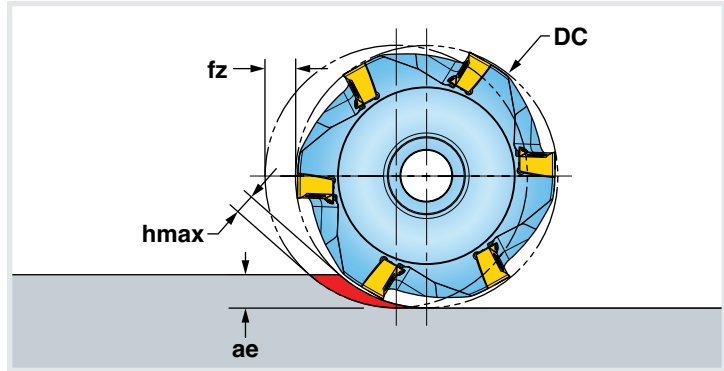

ISO	Materials			Vc Cutting Speed SFM	fz* Feed/Tooth (inch)	Harder «-----» Tougher			Coolant
	Material Group #VDI 3323	Type	Examples			IN2504	IN2505	IN2530	
P	1-5	Non-Alloy Steel	1018, A36, 1045, A572, 1070	400-1000	.003-.010	3	2	1	No
	6-9	Low-Alloy Steel	4140, 4340, P20, 8620, 300M	350-700					
	10-11	High-Alloy Steel	H13, A2, D2, M2, T1	300-600					
K	15-16	Gray Cast Iron	CLS. 20, 30, 45	500-1000	.003-.010	1	2	-	No
	17-20	Nodular Cast Iron	60-40-18, 100-70-03	400-800					
H	38-39	Hardened Steel > 48	A2, 01, D2	130-250	.003-.005	1	-	-	No

Note: Feed and speed recommendations are starting operating parameters. They are only guidelines from which further optimization should take place. Operating parameters are influenced by many machining variables. These variables may cause for reductions in feeds and speed or dramatic increases. Additionally, DOC and WOC may need to be revised to optimize the tools performance.

12 mm • Operating Guidelines

CHIP THINNING

When a_e is less than 25%,
Chip Thinning Calculator
is recommended to ensure
 h_{max} is within f_z range. ▶

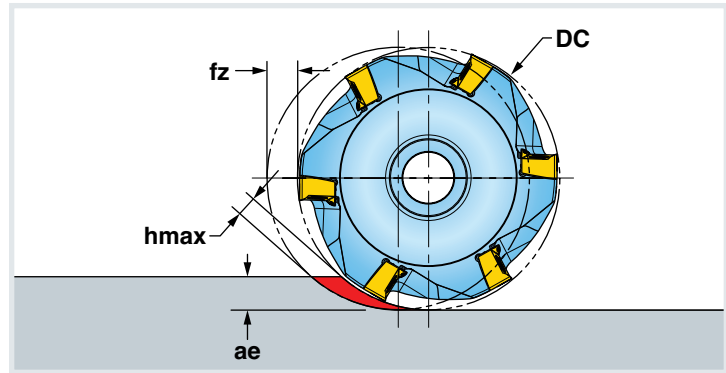

ISO	Material Group #VDI 3323	Type	Examples	Vc Cutting Speed SFM	fz* Feed/Tooth (inch)	Harder «-----» Tougher				Coolant
						IN2504	IN2510	IN2505	IN6537	
P	1-5	Non-Alloy Steel	1018, A36, 1045, A572, 1070	400-1000	.003-.010					No
	6-9	Low-Alloy Steel	4140, 4340, P20, 8620, 300M	350-700		3	-	2	1	
	10-11	High-Alloy Steel	H13, A2, D2, M2, T1	300-600						
K	15-16	Gray Cast Iron	CLS. 20, 30, 45	500-1000	.003-.010					No
	17-20	Nodular Cast Iron	60-40-18, 100-70-03	400-800		2	1	3	-	
H	38-39	Hardened Steel >48	A2, O1, D2	130-250	.003-.005	1	-	-	-	No

Note: Feed and speed recommendations are starting operating parameters. They are only guidelines from which further optimization should take place. Operating parameters are influenced by many machining variables. These variables may cause for reductions in feeds and speed or dramatic increases. Additionally, DOC and WOC may need to be revised to optimize the tools performance.