

## 10 mm • Operating Guidelines

### CHIP THINNING

When  $ae$  is less than 25%,  
**Chip Thinning Calculator**  
is recommended to ensure  
 $h_{max}$  is within  $fz$  range. ▶

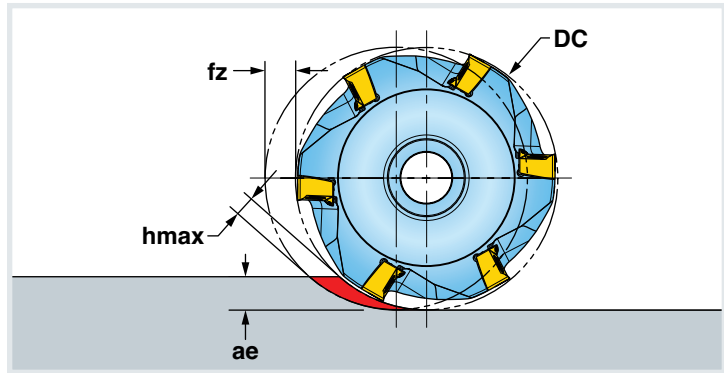

ISO	Materials			Vc Cutting Speed SFM	fz* Feed/Tooth (inch)	Harder «-----» Tougher			Coolant
	Material Group #VDI 3323	Type	Examples			IN2504	IN2505	IN2530	
<b>P</b>	1-5	Non-Alloy Steel	1018, A36, 1045, A572, 1070	400-1000	.003-.010	3	2	1	No
	6-9	Low-Alloy Steel	4140, 4340, P20, 8620, 300M	350-700					
	10-11	High-Alloy Steel	H13, A2, D2, M2, T1	300-600					
<b>K</b>	15-16	Gray Cast Iron	CLS. 20, 30, 45	500-1000	.003-.010	1	2	-	No
	17-20	Nodular Cast Iron	60-40-18, 100-70-03	400-800					
<b>H</b>	38-39	Hardened Steel > 48	A2, 01, D2	130-250	.003-.005	1	-	-	No

Note: Feed and speed recommendations are starting operating parameters. They are only guidelines from which further optimization should take place. Operating parameters are influenced by many machining variables. These variables may cause for reductions in feeds and speed or dramatic increases. Additionally, DOC and WOC may need to be revised to optimize the tools performance.