



Cutter Series (Depth of Cut):
12J1A
(90°=.19" / Hi-Feed =.02")

Insert Series:
90°: FNCT05_AL, FNHT05-ML,
FNKT05-M, FNHT05_L
Backdraft: FNHT05_SW
Hi-Feed: UNKT05-HF

Diameter Range:
.250"-.500"
6.00-20.00mm

Adaptions:
Cylindrical, Weldon,
Top-On, and ChipSurfer

Corner Radii:
.008", .015"R, and Hi-Feed

Materials:
Cast Iron, Steel,
Stainless Steel,
High-Temp Alloys,
Titanium, and Hard Steel

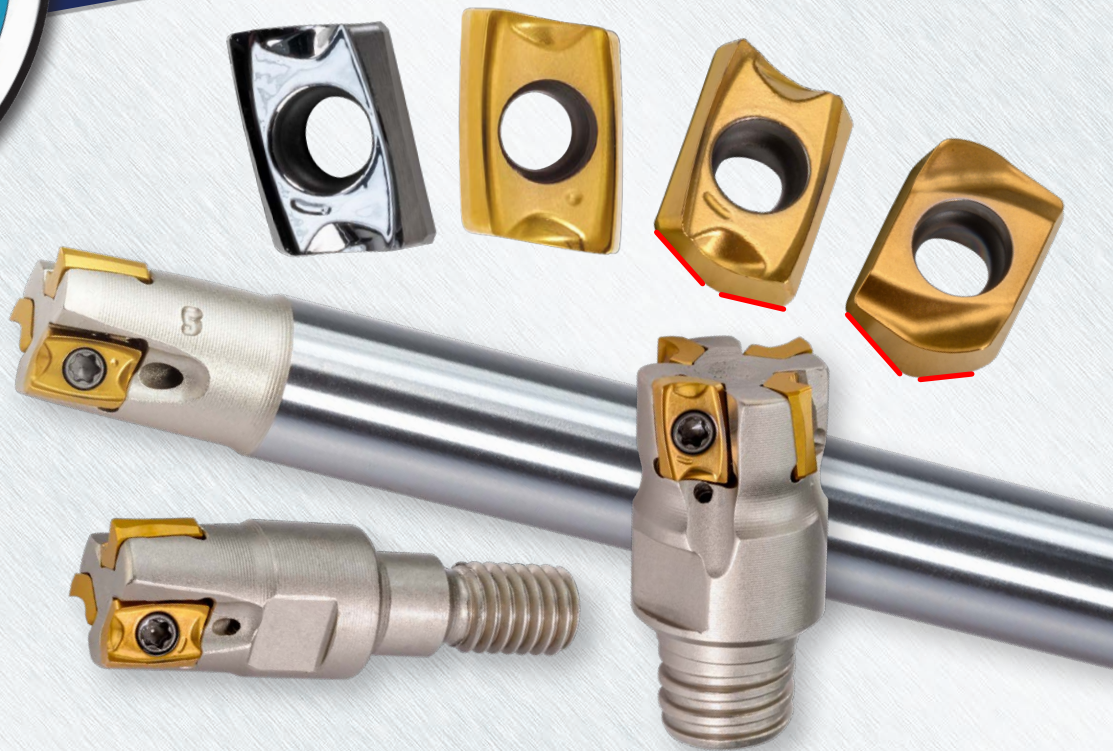

Mini-Sized 90° Shoulder Mill & Hi-Feed with Strong V-Shaped Insert

HiPosSFeedV is ideal for the small parts and miniature industry. When compared to solid carbide end mills, HiPosSFeedV offers the advantages of insert-indexing economy and productivity. Designed with versatility in mind, cutters are capable to ramp/interpolate and inserts are offered with three geometry options.

Features & Benefits:

- FNKT-M is for 90° roughing, FNKT-L is for 90° finishing with lower cutting forces, -SW is for finishing long reach side walls and UNKT-HF is for Hi-Feed Roughing
- 90°, Backdraft and Hi-Feed inserts fit the same pockets
- Integrated wiper flats produce 32-63 Ra surface finishes
- V-Bottom pocket fosters easy insert indexing, increased core diameter and minimizes insert screw stress
- High cutter densities with small IC insert sizes
- All cutters are plumbed with coolant through the tool
- Economical solid carbide alternative!

HIPOSSPEED V™ 05 FEATURES

Small diameter with a strong edge

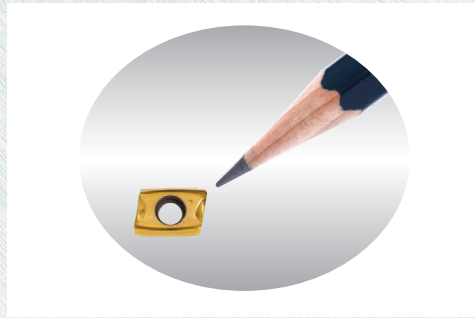

Finer pitch maximizes productivity compared to the competition

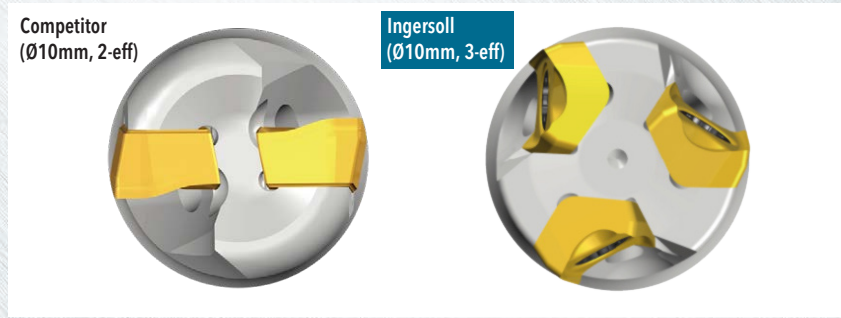

Min. holder dia. Ø6 (1-eff), Ø8 (2-eff)

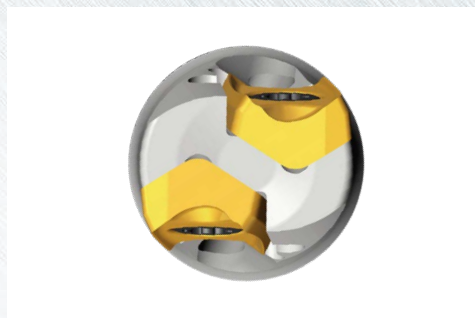

Stronger core diameter over the competitor's APKT type cutter

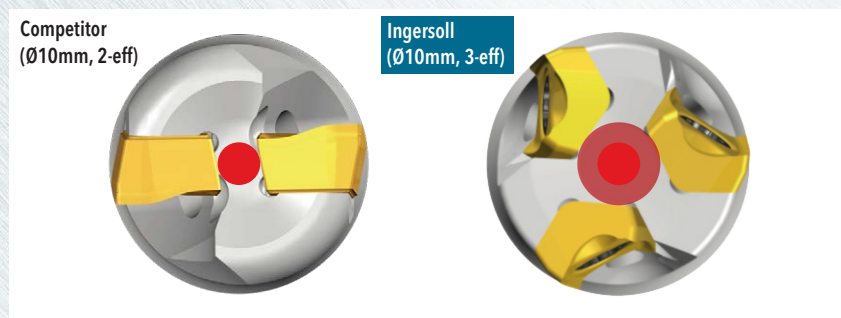

Unique V shape insert bottom design

- Increased insert rigidity
- Improved self-positioning for strong insert clamping

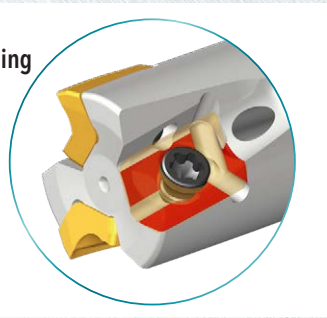
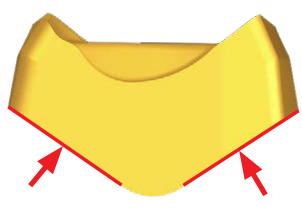

High-rake angle design reduces cutting loads, which results in excellent chip evacuation

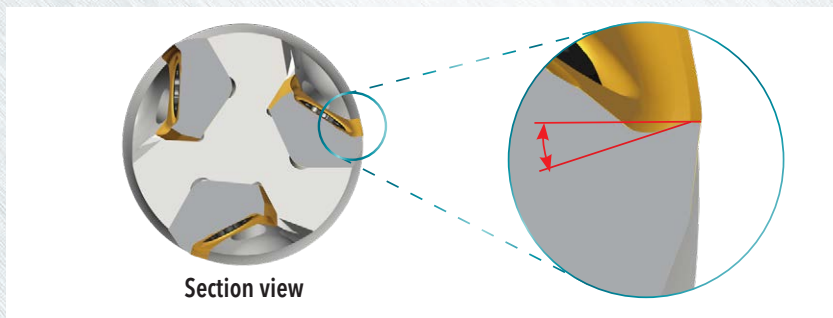



HIPOSSFEEDV™ 05 SERIES 12J1A (WELDON SHANK)

90° END MILL (5MM INSERT)

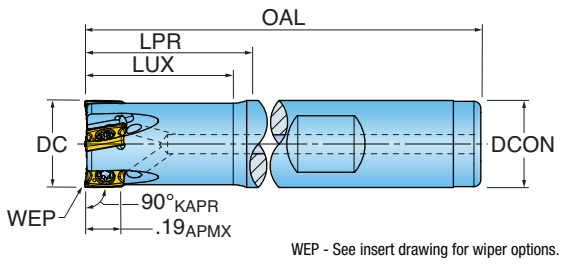
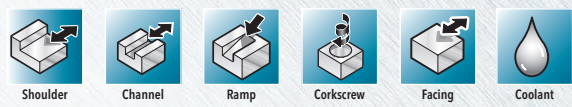

Part Number	DC Cutting Diameter	LUX Usable Length Max.	LPR Protruding Length	OAL Overall Length	ZEFF Effective Teeth	DCON Shank Diameter
12J1A-0300977R01	0.375	0.90	0.94	2.50	3	0.375
12J1A-0400978R01	0.437	0.93	0.97	2.75	3	0.500
12J1A-0500978R01	0.500	0.93	0.97	2.75	4	0.500
12J1A-0501079R01	0.500	1.05	1.09	3.00	4	0.625

* When using Hi-Feed Insert, modify body corner to R.070.



HIPOSSPEED[™] 05 SERIES 12J1A (CYLINDRICAL SHANK)

90° END MILL (5MM INSERT)

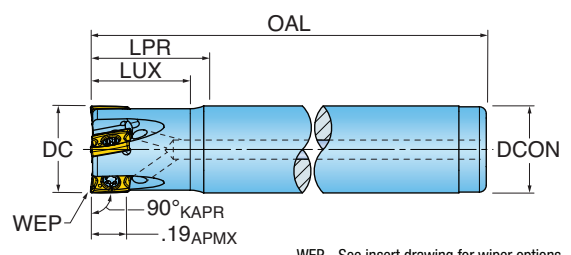
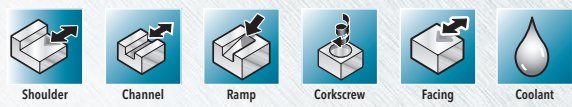

INCH

Part Number	DC Cutting Diameter	LUX Usable Length Max.	LPR Protruding Length	OAL Overall Length	ZEFF Effective Teeth	DCON Shank Diameter
12J1A-02005R6R01	0.250	0.45	1.08	2.50	1	0.250
12J1A-03005R7R01	0.312	0.45	1.08	2.50	2	0.312
12J1A-03006R8R01	0.375	0.60	1.08	2.50	3	0.375
12J1A-04006S4R01	0.437	0.60	1.22	3.00	3	0.500
12J1A-05006S4R01	0.500	0.60	1.22	3.00	4	0.500

METRIC

Part Number	DC Cutting Diameter	LUX Usable Length Max.	OAL Overall Length	ZEFF Effective Teeth	DCON Shank Diameter
12J1A006012T7R00	6.00 mm	12.0 mm	60.0 mm	1	6.00 mm
12J1A008012T0R00	8.00 mm	12.0 mm	80.0 mm	2	8.00 mm
12J1A009012T0R00	9.00 mm	12.0 mm	80.0 mm	2	8.00 mm
12J1A010015T1R00	10.00 mm	15.0 mm	80.0 mm	3	10.00 mm
12J1A011012T1R00	11.00 mm	12.0 mm	80.0 mm	3	10.00 mm
12J1A012015T2R00	12.00 mm	15.0 mm	80.0 mm	4	12.00 mm
12J1A013012T2R00	13.00 mm	12.0 mm	80.0 mm	4	12.00 mm
12J1A014012T2R00	14.00 mm	12.0 mm	80.0 mm	4	12.00 mm

* When using Hi-Feed Insert, modify body corner to R.070.
Designed with modification in mind. Extend usable length by turning back the neck diameter or shorten the overall length by cutting off back end.



HIPOSSFEED[™] 05 SERIES 12J1A (TOP•ON STYLE)

90° MODULAR END MILL (5MM INSERT)

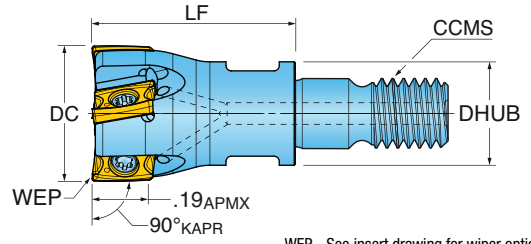
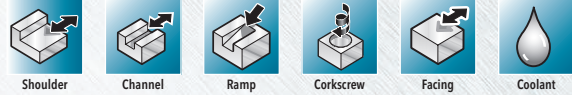

WEP - See insert drawing for wiper options.

INCH

Part Number	DC Cutting Diameter	LF Functional Length	ZEFF Effective Teeth	CCMS Connection Code	DHUB Hub Diameter
12J1A-05007X4R01	0.500	0.75	4	TopOn M06	0.38

METRIC

Part Number	DC Cutting Diameter	LF Functional Length	ZEFF Effective Teeth	CCMS Connection Code	DHUB Hub Diameter
12J1A010017X4R00	10.00 mm	17.0 mm	3.000	TopOn M06	9.8 mm
12J1A012017X4R00	12.00 mm	17.0 mm	4.000	TopOn M06	11.8 mm
12J1A015023X5R00	15.00 mm	23.0 mm	5.000	TopOn M08	12.8 mm
12J1A016023X5R00	16.00 mm	23.0 mm	5.000	TopOn M08	12.8 mm
12J1A020030X6R00	20.00 mm	30.0 mm	6.000	TopOn M10	17.8 mm

* When using Hi-Feed Insert, modify body corner to R.070.



HIPOSSPEED[™] 05 SERIES 12J1A (CHIPSURFER STYLE)

90° MODULAR END MILL (5MM INSERT)

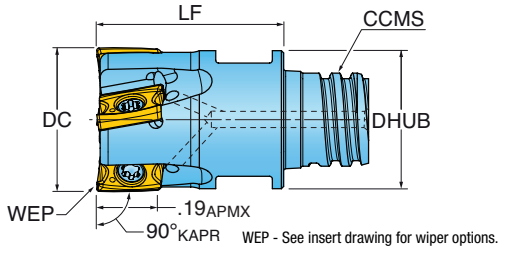
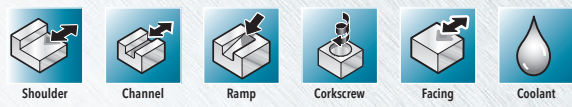

INCH

Part Number	DC Cutting Diameter	LF Functional Length	ZEFF Effective Teeth	CCMS Connection Code	DHUB Hub Diameter
12J1A-03006T6R01	0.375	0.63	3	Chip Surfer T06	0.36
12J1A-05006T8R01	0.500	0.65	4	Chip Surfer T08	0.48

METRIC

Part Number	DC Cutting Diameter	LF Functional Length	ZEFF Effective Teeth	CCMS Connection Code	DHUB Hub Diameter
12J1A008010TQR00	8.00 mm	10.0 mm	2	Chip Surfer T05	9.6 mm
12J1A010016T6R00	10.00 mm	16.0 mm	3	Chip Surfer T06	9.6 mm
12J1A012017T8R00	12.00 mm	17.0 mm	4	Chip Surfer T08	11.5 mm

* When using Hi-Feed Insert, modify body corner to R.070.



HIPOSSPEED[™] 05 INSERTS

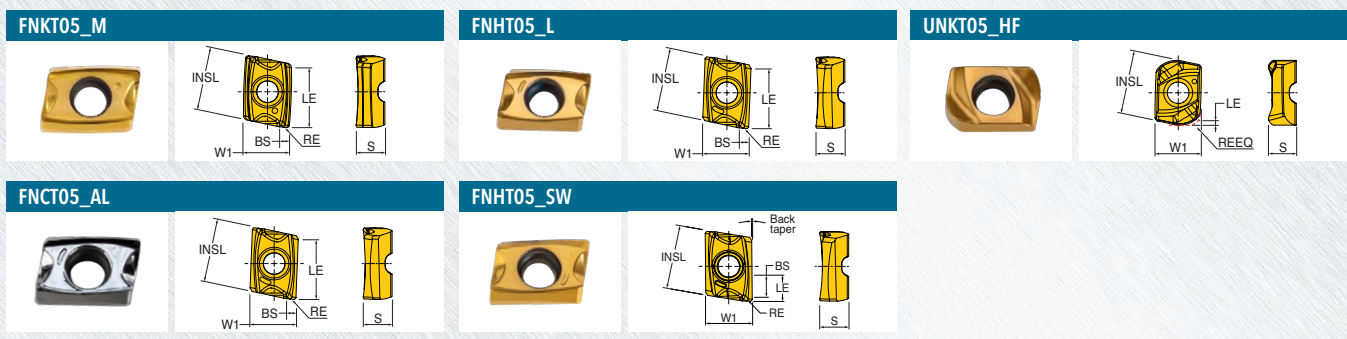

Part Number	Application	RE Corner Radius	BS Wiper Length	LE Cutting Edge Eff. Length	INSL Insert Length	W1 Insert Width	S Thickness	NOI Number of Indexes	IH Insert Hand	Grade	IN05S	IN2005	IN2505	IN2530
FNCT050202R-AL	Grd/Pol for Al	0.008	0.013	0.190	0.248	0.165	0.102	2	Right		•			
FNKT050202R-M	Multi-Purpose	0.008	0.013	0.190	0.248	0.165	0.102	2	Right			•	•	
FNHT050202R-L	Multi-Purpose, Keen Edge	0.008	0.013	0.190	0.248	0.165	0.102	2	Right			•	•	•
FNKT050204R-M	Multi-Purpose	0.015	0.013	0.190	0.248	0.165	0.102	2	Right				•	•
FNHT050202R-SW	Backdraft - Side Wiper	0.008	0.039	0.047	0.249	0.161	0.101	2	Right				•	

Part Number	Application	REEQ Program Radius Equivalent	LE Cutting Edge Eff. Length	INSL Insert Length	W1 Insert Width	S Thickness	NOI Number of Indexes	IH Insert Hand	Grade	IN2504	IN2505	IN2530
UNKT0502TR-HF	Hi-Feed	0.030	0.019	0.216	0.165	0.098	2	Right		•	•	•



HIPOSSPEED[™] 05 HARDWARE



INCH

12J1A-0300977R01	SM18-033-00	DS-TP06S-NEU	-	-	DS-A00-.25-S	DT-05-.25	DS-TP06B
12J1A-0400978R01	SM18-033-00	DS-TP06S-NEU	-	-	DS-A00-.25-S	DT-05-.25	DS-TP06B
12J1A-0500978R01	SM18-033-00	DS-TP06S-NEU	-	-	DS-A00-.25-S	DT-05-.25	DS-TP06B
12J1A-0501079R01	SM18-033-00	DS-TP06S-NEU	-	-	DS-A00-.25-S	DT-05-.25	DS-TP06B
12J1A-02005R6R01	SM18-033-00	DS-TP06S-NEU	-	-	DS-A00-.25-S	DT-05-.25	DS-TP06B
12J1A-03005R7R01	SM18-033-00	DS-TP06S-NEU	-	-	DS-A00-.25-S	DT-05-.25	DS-TP06B
12J1A-03006R8R01	SM18-033-00	DS-TP06S-NEU	-	-	DS-A00-.25-S	DT-05-.25	DS-TP06B
12J1A-04006S4R01	SM18-033-00	DS-TP06S-NEU	-	-	DS-A00-.25-S	DT-05-.25	DS-TP06B
12J1A-05006S4R01	SM18-033-00	DS-TP06S-NEU	-	-	DS-A00-.25-S	DT-05-.25	DS-TP06B
12J1A-05007X4R01	SM18-033-00	DS-TP06S-NEU	-	-	DS-A00-.25-S	DT-05-.25	DS-TP06B
12J1A-03006T6R01	SM18-033-00	DS-TP06S-NEU	WS-0029	DT-90-08	DS-A00-.25-S	DT-05-.25	DS-TP06B
12J1A-05006T8R01	SM18-033-00	DS-TP06S-NEU	WS-0030	DT-130-10	DS-A00-.25-S	DT-05-.25	DS-TP06B

METRIC

12J1A006012T7R00	SM18-033-00	DS-TP06S-NEU			DS-A00-.25-S	DT-05-.25	DS-TP06B
12J1A008012TOR00	SM18-033-00	DS-TP06S	-	-	DS-A00-.25-S	DT-05-.25	DS-TP06B
12J1A009012TOR00	SM18-033-00	DS-TP06S	-	-	DS-A00-.25-S	DT-05-.25	DS-TP06B
12J1A010015T1R00	SM18-033-00	DS-TP06S	-	-	DS-A00-.25-S	DT-05-.25	DS-TP06B
12J1A011012T1R00	SM18-033-00	DS-TP06S	-	-	DS-A00-.25-S	DT-05-.25	DS-TP06B
12J1A012015T2R00	SM18-033-00	DS-TP06S	-	-	DS-A00-.25-S	DT-05-.25	DS-TP06B
12J1A013012T2R00	SM18-033-00	DS-TP06S	-	-	DS-A00-.25-S	DT-05-.25	DS-TP06B
12J1A014012T2R00	SM18-033-00	DS-TP06S	-	-	DS-A00-.25-S	DT-05-.25	DS-TP06B
12J1A010017X4R00	SM18-033-00	DS-TP06S-NEU	-	-	DS-A00-.25-S	DT-05-.25	DS-TP06B
12J1A012017X4R00	SM18-033-00	DS-TP06S-NEU	-	-	DS-A00-.25-S	DT-05-.25	DS-TP06B
12J1A015023X5R00	SM18-033-00	DS-TP06S-NEU	-	-	DS-A00-.25-S	DT-05-.25	DS-TP06B
12J1A016023X5R00	SM18-033-00	DS-TP06S-NEU	-	-	DS-A00-.25-S	DT-05-.25	DS-TP06B
12J1A020030X6R00	SM18-033-00	DS-TP06S-NEU	-	-	DS-A00-.25-S	DT-05-.25	DS-TP06B
12J1A008010TQR00	SM18-033-00	DS-TP06S-NEU	WS-0043	DT-60-04	DS-A00-.25-S	DT-05-.25	DS-TP06B
12J1A010016T6R00	SM18-033-00	DS-TP06S	WS-0029	DT-90-08	DS-A00-.25-S	DT-05-.25	DS-TP06B
12J1A012017T8R00	SM18-033-00	DS-TP06S	WS-0030	DT-130-10	DS-A00-.25-S	DT-05-.25	DS-TP06B

* Insert screw torque is 5.3 in. lbs.



HIPOSSPEED[™] 05 OPERATING GUIDELINES: 90° SHOULDER & PLUNGE (FNKT, FNHT)

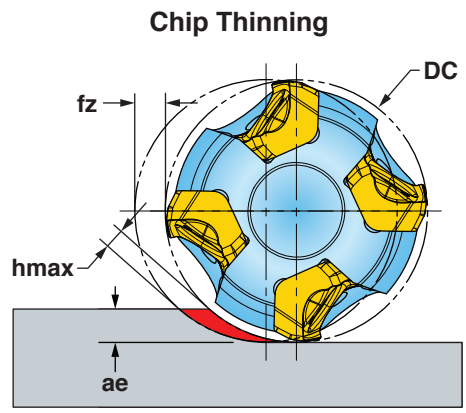

* When ae is less than 25% DC, recommend use of Chip Thinning Calculator to ensure hmax is in fz range.

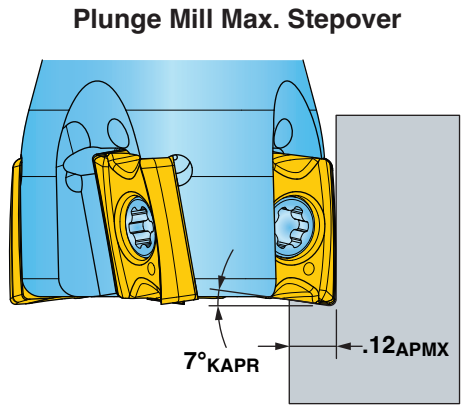

ISO	Materials			Vc Cutting Speed SFM	fz* Feed/Tooth (inch)	Harder Tougher				Coolant
	Mat'l Group #VDI 3323	Type	Examples			IN05S	IN200S	IN250S	IN2530	
P	1 thru 5	Non-alloy Steel	1018, A36, 1045, A572, 1070	400-1000	.0015-.0040	-	3	2	1	No
	6 thru 9	Low-alloy Steel	4140, 4340, P20, 8620, 300M	350-700						
	10, 11	High-alloy Steel	H13, A2, D2, M2, T1	300-600						
M	12 thru 13	Stainless Steel (Ferritic & Martensitic)	410, 416, 440	350-600	.0015-.0040	-	1	2	3	Yes
	14	Stainless Steel (Austenitic)	303, 304, 316, 15-5, 17-4	300-550		May not be required at high speeds				
K	15 thru 16	Gray Cast Iron	CLS. 20, 30, 45	500-1000	.0015-.0040	-	1	2	-	No
	17 thru 20	Nodular Cast Iron	60-40-18, 100-70-03	400-800						
N	21 thru 30	Aluminum	7075, 6061	1000-3000	.0010-.0050	1	-	-	-	Yes
S	31 thru 35	High-Temp Alloys	Inconel, Hastelloy, Nimonic, Monel	65-150	.0015-.0040	-	1	2	3	Yes
	36 thru 37	Titanium Alloys	6Al-4V, 5Al-5Mo-5V-3Cr	85-200		-	2	3	1	
H	38 thru 39	Hardened Steel >48	A2, O1, D2	130-250	.0015-.0030	-	1	2	-	No

Note: Feed and speed recommendations are starting operating parameters. They are only guidelines from which further optimization should take place. Operating parameters are influenced by many machining variables. These variables may cause for reductions in feeds and speed or dramatic increases. Additionally, DOC and WOC may need to be revised to optimize the tools performance.



MILLING PRODUCTS

HIPOSSPEED[™] 05

OPERATING GUIDELINES: HI-FEED (UNKT)

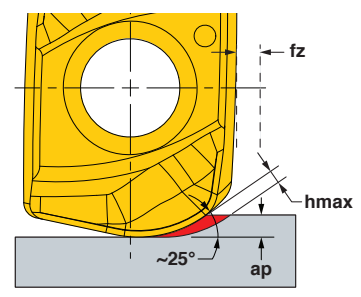

Chip Thinning
 *Chip Thinning Calculator is recommended to ensure hmax is within range.

ISO	Materials			Vc Cutting Speed SFM	fz Feed/Tooth (inch)	ap Axial Depth of Cut (inch)	hmax* Chip Thickness (inch)	Harder Tougher			Coolant
	Mat'l Group #VDI 3323	Type	Examples					IN2504	IN2505	IN2530	
P	1 thru 5	Non-alloy Steel	1018, A36, 1045, A572, 1070	400-1000	.012-.025	.008-.016	.003-.009	1	2		No
	6 thru 9	Low-alloy Steel	4140, 4340, P20, 8620, 300M	350-700							
	10, 11	High-alloy Steel	H13, A2, D2, M2, T1	300-600							
M	12 thru 13	Stainless Steel (Ferritic & Martensitic)	410, 416, 440	350-600	.012-.020	.008-.016	.003-.008	2	1		Yes
	14	Stainless Steel (Austenitic)	303, 304, 316, 15-5, 17-4	300-550							
K	15 thru 16	Gray Cast Iron	CLS. 20, 30, 45	500-1000	.012-.025	.008-.016	.003-.009	1	2		No
	17 thru 20	Nodular Cast Iron	60-40-18, 100-70-03	400-800							
S	31 thru 35	High-Temp Alloys	Inconel, Hastelloy, Nimonic, Monel	65-150	.012-.020	.008-.016	.003-.009	2	1		Yes
	36 thru 37	Titanium Alloys	6Al-4V, 5Al-5Mo-5V-3Cr	85-200							
H	38 thru 39	Hardened Steel >48	A2, O1, D2	130-250	.012-.018	.008-.012	.003-.007	1	2		No

Note: Feed and speed recommendations are starting operating parameters. They are only guidelines from which further optimization should take place. Operating parameters are influenced by many machining variables. These variables may cause for reductions in feeds and speed or dramatic increases. Additionally, DOC and WOC may need to be revised to optimize the tools performance.

HIPOSSPEED[™] 05 PROGRAMMING DATA (UNKT05)

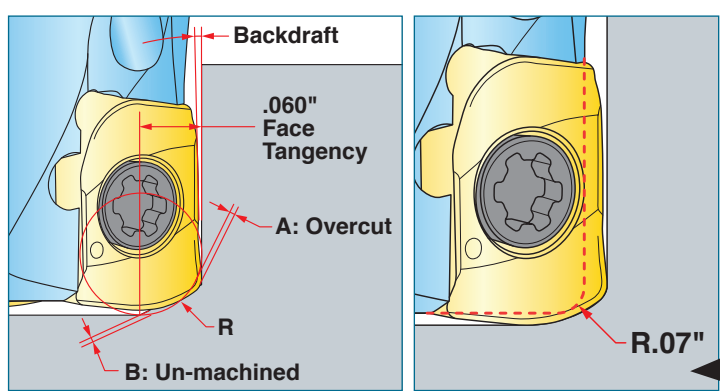

Insert	R Program	A Overcut	B Un-machined
UNKT05	.030	0	.010
	.035	0	.007
	.040	.001	.005

A programmed radius of .030" is recommended.

When using the Hi-Feed insert, modify the body corner to R.07".

HIPOSSPEED[™] 05 RAMPING DATA: 90° (FNKT, FNHT)

Straight Ramping

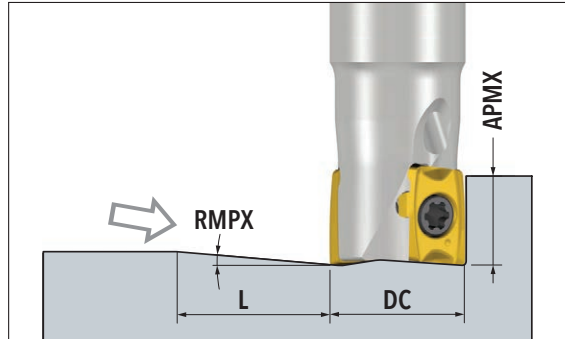

Helical Ramping

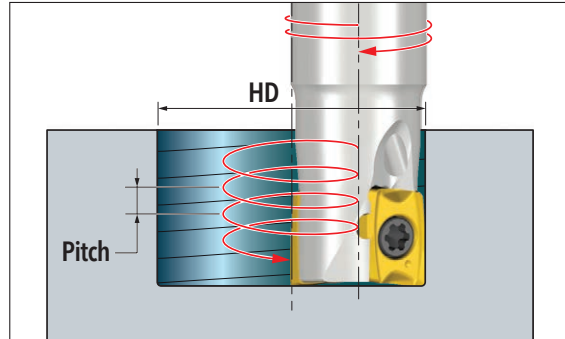

DC Cutter Diameter	Straight Ramp			Helical Ramp		
	RMPX Ramp Angle Max.	APMX Depth of Cut Max.	L Ramp Length Min.	HD Hole Diameter Min.	HD Hole Diameter Max.	Pitch Max.
.250	2.5	.19	4.4	.25	.50	.004
						.026
.312	2.1	.19	5.3	.41	.62	.008
						.029
.375	1.7	.19	6.5	.53	.75	.015
						.029
.437	1.3	.19	8.5	.65	.87	.012
						.027
.500	1.1	.19	9.5	.78	1.00	.015
						.027



HIPOSSPEED[™] 05 RAMPING DATA: HI-FEED (UNKT05)

Straight Ramping

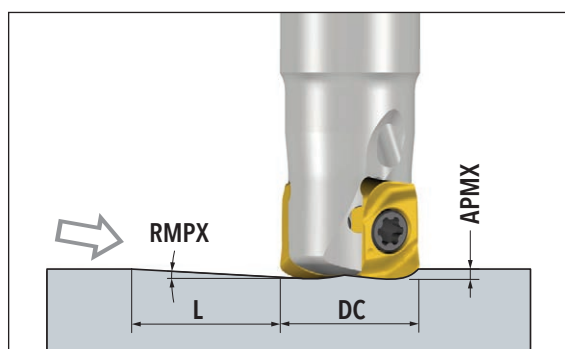

Helical Ramping

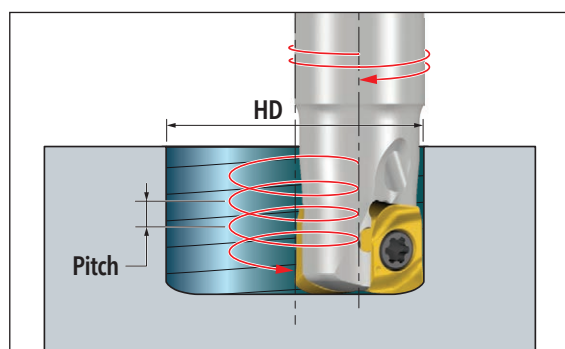

DC Cutter Diameter	Straight Ramp			Helical Ramp		
	RMPX Ramp Angle Max.	APMX Depth of Cut Max.	L Ramp Length Min.	HD Hole Diameter Min.	HD Hole Diameter Max.	Pitch Max.
.250	0.2	.019	5.6	.25	.50	.000
						.004
.312	0.4	.019	2.5	.41	.62	.004
						.007
.375	0.3	.019	3.5	.53	.75	.004
						.007
.437	0.3	.019	3.2	.65	.87	.004
						.007
.500	0.7	.019	1.4	.78	1.00	.010
						.020