

**HIPOSSPEED<sup>™</sup> 05 RAMPING DATA: HI-FEED (UNKT05)**

**Straight Ramping**

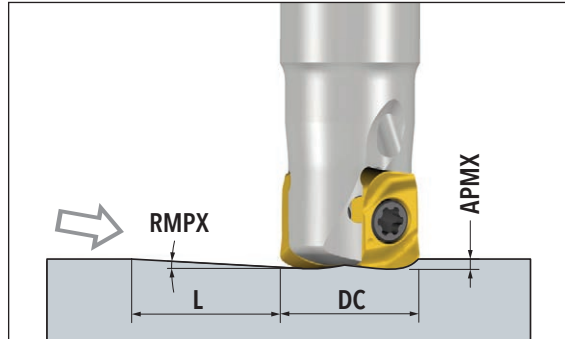

**Helical Ramping**

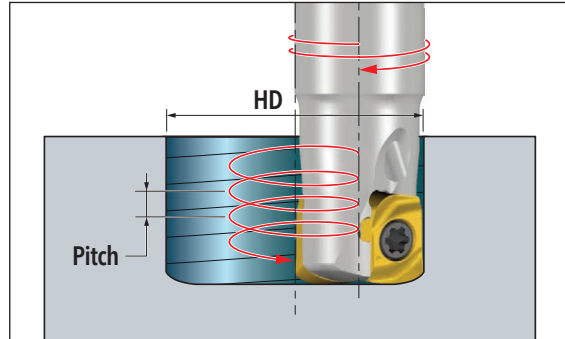

DC Cutter Diameter	Straight Ramp			Helical Ramp		
	RMPX Ramp Angle Max.	APMX Depth of Cut Max.	L Ramp Length Min.	HD Hole Diameter Min.	HD Hole Diameter Max.	Pitch Max.
.250	0.2	.019	5.6	.25		.000
					.50	.004
.312	0.4	.019	2.5	.41		.004
					.62	.007
.375	0.3	.019	3.5	.53		.004
					.75	.007
.437	0.3	.019	3.2	.65		.004
					.87	.007
.500	0.7	.019	1.4	.78		.010
					1.00	.020