



Tip Series: Style
48E: Barrel Form Finish Mill
46D/47D: Lens Form Finish Mill
46W/47W: Taper Form Finish Mill

Diameter Range
8mm - 20mm
.312" - .500"

Adaption
T05, T06, T08, T10 & T12

Materials
Steel, Stainless Steel, Iron, Hi-Temp
Alloys, Titanium, Aluminum

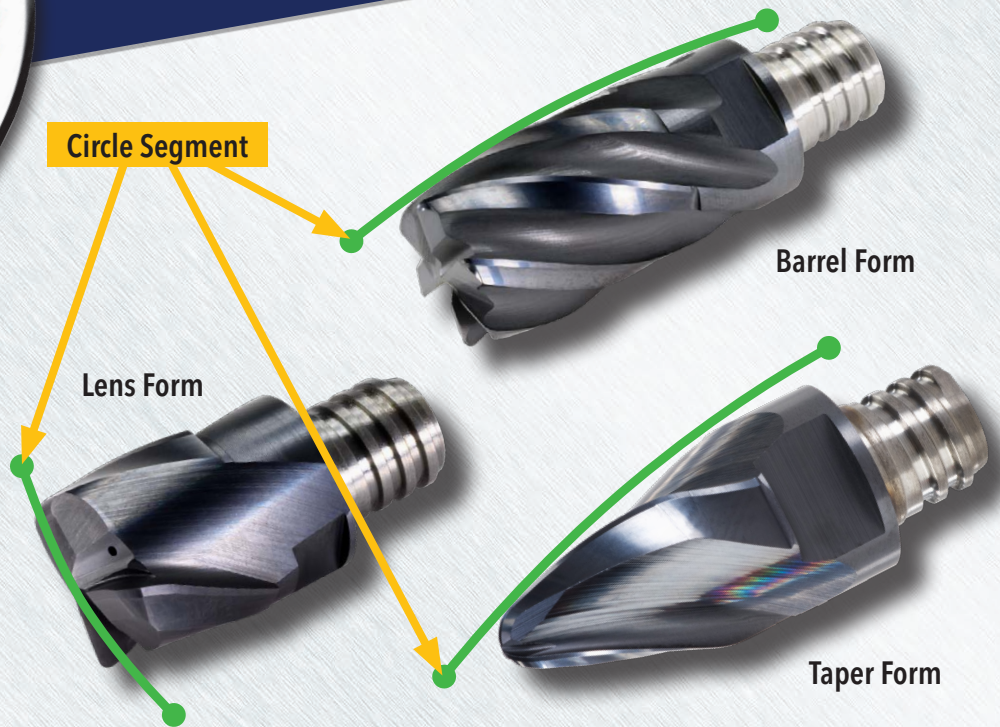

Circle Segment Mills Finish 3x Faster than a Ball Nose!

Ingersoll is pleased to announce an expansion of the Chip Surfer Circle Segment Finishing line with the addition of the Lens and Barrel Forms to the existing Taper Form. Each style produces smoother finishes with less machine time than ballnose by leveraging the unique "radius form" or "crown" with larger stepovers. Each style is also conducive to machine type and part feature.

Features & Benefits:

- Lens Form targets use on deck features of a part. For use on 3 & 5 Axis machines.
- Barrel Form targets use on 90° & drafted walls. For use on 3 & 5 Axis machines.
- Taper Form targets use on contoured surfaces. For use on 5 Axis machines.
- Radius blends ensure minimum scallop height for superior finishes.
- Precision cutting edge profile tolerance of $\pm .0004"$
- Tips repeat within $\pm .0005"$ and can be indexed on the machine in seconds
- Steel, Heavy Metal & Carbide Shank options.



CHIPSURFER™ COMPARISONS

Ball Nose end mill

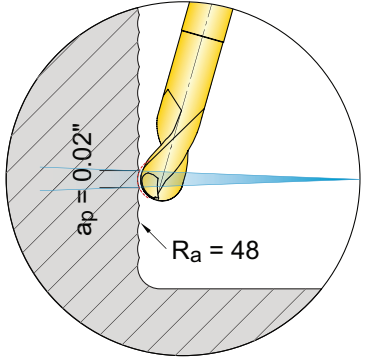

Taper-form end mill

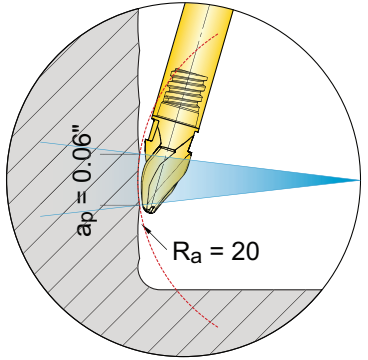

Ball nose end mill

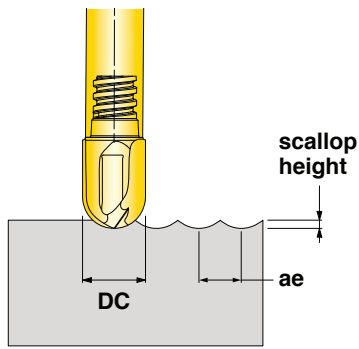

Lens-form end mill

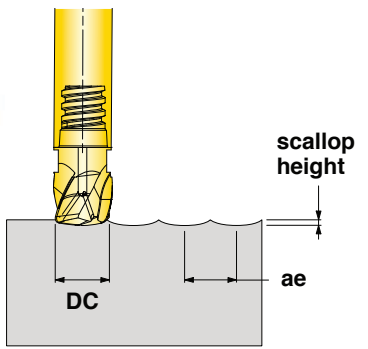

**Ball-Nose vs. Lens-Shape Stepcor Comparison
.0001" (0.25mm) Scallop Height**

Ball Dia.	ae	Lens Dia.	ae
8mm	0.28mm	8mm	0.55mm
10mm	0.32mm	10mm	0.63mm
12mm	0.35mm	12mm	0.71mm
16mm	0.40mm	16mm	0.84mm
20mm	0.45mm	20mm	0.95mm

**Ball-Nose vs. Lens-Shape Stepcor Comparison
.0002" (0.50mm) Scallop Height**

Ball Dia.	ae	Lens Dia.	ae
8mm	0.40mm	8mm	0.77mm
10mm	0.45mm	10mm	0.89mm
12mm	0.49mm	12mm	1.00mm
16mm	0.57mm	16mm	1.18mm
20mm	0.63mm	20mm	1.34mm

Ball Nose end mill

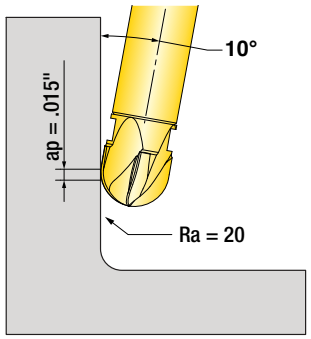

Barrel-form end mill

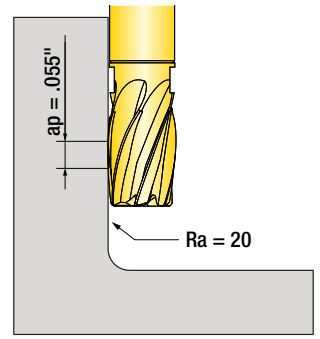



CHIPSURFER™ SERIES 46W_0: TAPER FORM FINISHER

3-FLUTE, 30° HELIX, FOR STEELS AND HI-TEMPS

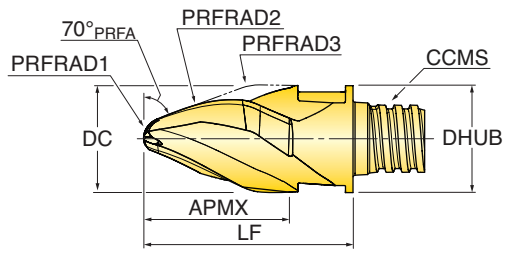

Part Number	DC Cutting Diameter	PRFRAD1 Profile Radius	PRFRAD2 Profile Radius	PRFRAD3 Profile Radius	APMX Depth of Cut Max.	LF Functional Length	ZEFF Effective Flutes	FHA Flute Helix Angle	CCMS Connection Code	DHUB Hub Diameter
46W08009TORB010	8.00 mm	1.50 mm	250.00 mm	4.00 mm	10 mm	15.40 mm	3	30	Chip Surfer T05	7.60 mm
46W10013T6RB020	10.00 mm	2.00 mm	250.00 mm	5.00 mm	14 mm	19.40 mm	3	30	Chip Surfer T06	9.30 mm
46W12013T8RB030	12.00 mm	3.00 mm	250.00 mm	6.00 mm	14 mm	23.40 mm	3	30	Chip Surfer T08	11.50 mm
46W16017TRRB040	16.00 mm	4.00 mm	500.00 mm	8.00 mm	17 mm	26.00 mm	3	30	Chip Surfer T10	15.20 mm

*When assembling, be sure tip is seated firmly on shank with no gap.
No lubricant on adaption.
Wrenches sold separately.

CHIPSURFER™ 46W_0 HARDWARE

			Tightening Torque (in. lbs.)
	Thin Wrench	Torque Wrench	
46W08009TORB010	WS-0043	DT-60-06	60
46W10013T6RB020	WS-0029	DT-90-08	90
46W12013T8RB030	WS-0030	DT-130-10	130
46W16017TRRB040	WS-0044	DT-250-13	250



CHIPSURFER™ SERIES 46W_1: TAPER FORM FINISHER

3-FLUTE, 30° HELIX, FOR ALUMINUM

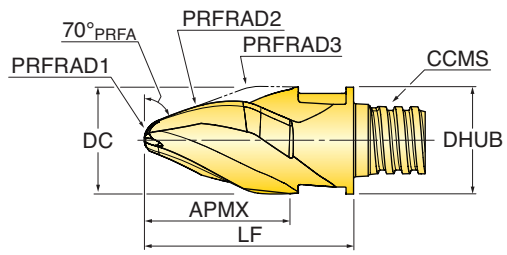
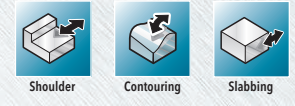

Part Number	DC Cutting Diameter	PRFRAD1 Profile Radius	PRFRAD2 Profile Radius	PRFRAD3 Profile Radius	APMX Depth of Cut Max.	LF Functional Length	ZEFF Effective Flutes	FHA Flute Helix Angle	CCMS Connection Code	DHUB Hub Diameter
46W08009TQRB011	8.00 mm	1.50 mm	250.00 mm	4.00 mm	10 mm	15.40 mm	3	30	Chip Surfer T05	7.60 mm
46W10013T6RB021	10.00 mm	2.00 mm	250.00 mm	5.00 mm	14 mm	19.40 mm	3	30	Chip Surfer T06	9.30 mm
46W12013T8RB031	12.00 mm	3.00 mm	250.00 mm	6.00 mm	14 mm	23.40 mm	3	30	Chip Surfer T08	11.50 mm
46W16017TRRB041	16.00 mm	4.00 mm	500.00 mm	8.00 mm	17 mm	26.00 mm	3	30	Chip Surfer T10	15.20 mm

*When assembling, be sure tip is seated firmly on shank with no gap.
No lubricant on adaption.
Wrenches sold separately.

CHIPSURFER™ 46W_1 HARDWARE

Part Number			Tightening Torque (in. lbs.)
	Thin Wrench	Torque Wrench	
46W08009TQRB011	WS-0043	DT-60-06	60
46W10013T6RB021	WS-0029	DT-90-08	90
46W12013T8RB031	WS-0030	DT-130-10	130
46W16017TRRB041	WS-0044	DT-250-13	250



CHIPSURFER™ SERIES 47W_0: TAPER FORM FINISHER

4-FLUTE, 30° HELIX, FOR STEELS AND HI-TEMPS

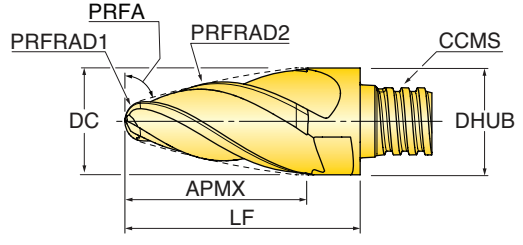

Part Number	DC Cutting Diameter	PRFRAD1 Profile Radius	PRFRAD2 Profile Radius	PRFA Profile Angle	APMX Depth of Cut Max.	LF Functional Length	ZEFF Effective Flutes	FHA Flute Helix Angle	CCMS Connection Code	DHUB Hub Diameter
47W-3150TQRB06	0.312	0.060	3.150	78	0.530	0.709	4	30	Chip Surfer T05	0.312
47W-3760T6RB12	0.375	0.123	2.950	82	0.600	0.866	4	30	Chip Surfer T06	0.375
47W-5082T8RB16	0.500	0.157	7.500	82	0.820	1.063	4	30	Chip Surfer T08	0.500

Metric

47W08014TQRB15	8.00 mm	1.50 mm	80.00 mm	78	14.20 mm	18.00 mm	4	30	Chip Surfer T05	8.00 mm
47W10016T6RB20	10.00 mm	2.00 mm	75.00 mm	78	21.30 mm	27.00 mm	4	30	Chip Surfer T06	10.00 mm
47W12021T8RB20	12.00 mm	2.00 mm	85.00 mm	78	16.50 mm	22.00 mm	4	30	Chip Surfer T08	12.00 mm
47W16027T8RB30	16.00 mm	3.00 mm	75.00 mm	78	27.00 mm	33.40 mm	4	30	Chip Surfer T10	16.00 mm

*When assembling, be sure tip is seated firmly on shank with no gap.
No lubricant on adaption.
Wrenches sold separately.

CHIPSURFER™ 47W_0 HARDWARE

			Tightening Torque (in. lbs.)
	Thin Wrench	Torque Wrench	
47W-3150TQRB06	WS-0043	DT-60-06	60
47W-3760T6RB12	WS-0029	DT-90-08	90
47W-5082T8RB16	WS-0030	DT-130-10	130
47W08014TQRB15	WS-0043	DT-60-06	60
47W10016T6RB20	WS-0029	DT-90-08	90
47W12021T8RB20	WS-0030	DT-130-10	130
47W16027T8RB30	WS-0044	DT-250-13	250



CHIPSURFER™ SERIES 47W_1: TAPER FORM FINISHER

4-FLUTE, 30° HELIX, FOR NON FERROUS MATERIALS

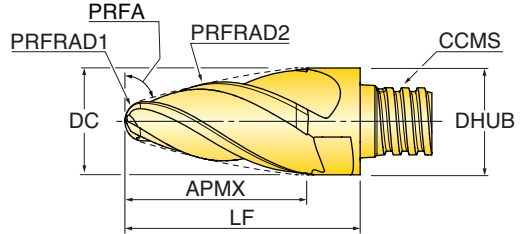

Part Number	DC Cutting Diameter	PRFRAD1 Profile Radius	PRFRAD2 Profile Radius	PRFA Profile Angle	APMX Depth of Cut Max.	LF Functional Length	ZEFF Effective Flutes	FHA Flute Helix Angle	CCMS Connection Code	DHUB Hub Diameter
47W-3150QRB061	0.312	0.060	3.150	78	0.530	0.709	4	30	Chip Surfer T05	0.312
47W-3760T6RB121	0.375	0.123	2.950	82	0.591	0.866	4	30	Chip Surfer T06	0.375
47W-5082T8RB161	0.500	0.157	7.500	82	0.827	1.063	4	30	Chip Surfer T08	0.500

Metric

47W08014QRB151	8.00 mm	1.50 mm	80.00 mm	78	14.20 mm	18.00 mm	4	30	Chip Surfer T05	8.00 mm
47W10016T6RB201	10.00 mm	2.00 mm	85.00 mm	78	16.50 mm	22.00 mm	4	30	Chip Surfer T06	10.00 mm
47W12021T8RB201	12.00 mm	2.00 mm	75.00 mm	78	21.30 mm	27.00 mm	4	30	Chip Surfer T08	12.00 mm
47W16027T8RB301	16.00 mm	3.00 mm	75.00 mm	78	27.00 mm	33.50 mm	4	30	Chip Surfer T10	16.00 mm

*When assembling, be sure tip is seated firmly on shank with no gap.
No lubricant on adaption.
Wrenches sold separately.

CHIPSURFER™ 47W_1 HARDWARE

			Tightening Torque (in. lbs.)
	Thin Wrench	Torque Wrench	
47W-3150QRB061	WS-0043	DT-60-06	60
47W-3760T6RB121	WS-0029	DT-90-08	90
47W-5082T8RB161	WS-0030	DT-130-10	130
47W08014QRB151	WS-0043	DT-60-06	60
47W10016T6RB201	WS-0029	DT-90-08	90
47W12021T8RB201	WS-0030	DT-130-10	130
47W16027T8RB301	WS-0044	DT-250-13	250



CHIPSURFER™ SERIES 46D_RB: LENS FORM FINISHER

3-FLUTE, 30° HELIX, COOLANT, FOR STEELS AND HI-TEMPS

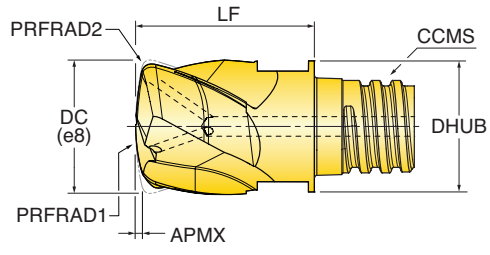

Part Number	DC Cutting Diameter	PRFRAD1 Profile Radius	PRFRAD2 Profile Radius	APMX Depth of Cut Max.	LF Functional Length	ZEFF Effective Flutes	FHA Flute Helix Angle	CCMS Connection Code	DHUB Hub Diameter
46D08005TQRB080	8.00 mm	15.00 mm	0.75 mm	0.10 mm	10.50 mm	3	30	Chip Surfer T05	7.75 mm
46D10007T6RB100	10.00 mm	20.00 mm	1.00 mm	0.10 mm	13.50 mm	3	30	Chip Surfer T06	9.40 mm
46D12009T8RB130	12.00 mm	25.00 mm	1.25 mm	0.15 mm	17.00 mm	3	30	Chip Surfer T08	11.40 mm
46D16013TRRB180	16.00 mm	35.00 mm	1.75 mm	0.30 mm	21.00 mm	3	30	Chip Surfer T10	15.40 mm
46D20016TSRB230	20.00 mm	45.00 mm	2.25 mm	0.40 mm	26.00 mm	3	30	Chip Surfer T12	18.40 mm

*When assembling, be sure tip is seated firmly on shank with no gap.
No lubricant on adaption.
Wrenches sold separately.

CHIPSURFER™ 46D_RB HARDWARE

			Tightening Torque (in. lbs.)
	Thin Wrench	Torque Wrench	
46D08005TQRB080	WS-0043	DT-60-06	60
46D10007T6RB100	WS-0029	DT-90-08	90
46D12009T8RB130	WS-0030	DT-130-10	130
46D16013TRRB180	WS-0044	DT-250-13	250
46D20016TSRB230	WS-0059	DT-250-16	250



CHIPSURFER™ SERIES 47D_RB: LENS FORM FINISHER

4-FLUTE, 30° HELIX, FOR STEELS AND HI-TEMPS

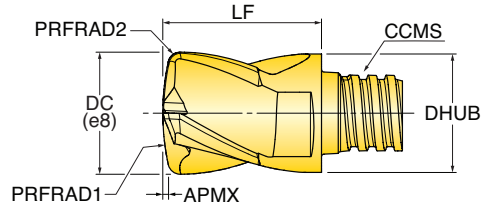

Part Number	DC Cutting Diameter	PRFRAD1 Profile Radius	PRFRAD2 Profile Radius	APMX Depth of Cut Max.	LF Functional Length	ZEFF Effective Flutes	FHA Flute Helix Angle	CCMS Connection Code	DHUB Hub Diameter
47D-3119TQRB02	0.312	0.625	0.020	0.004	0.394	4	30	Chip Surfer T05	0.312
47D-3725T6RB04	0.375	0.750	0.039	0.004	0.512	4	30	Chip Surfer T06	0.375
47D-5035T8RB04	0.500	1.000	0.039	0.006	0.650	4	30	Chip Surfer T08	0.500

Metric

47D08004TQRB05	8.00 mm	16.00 mm	0.50 mm	0.10 mm	10.00 mm	4	30	Chip Surfer T05	8.00 mm
47D10006T6RB10	10.00 mm	20.00 mm	1.00 mm	0.10 mm	13.00 mm	4	30	Chip Surfer T06	10.00 mm
47D12008T8RB10	12.00 mm	24.00 mm	1.00 mm	0.15 mm	16.50 mm	4	30	Chip Surfer T08	12.00 mm
47D16011TRRB10	16.00 mm	32.00 mm	1.00 mm	0.30 mm	20.50 mm	4	30	Chip Surfer T10	16.00 mm

*When assembling, be sure tip is seated firmly on shank with no gap.
No lubricant on adaption.
Wrenches sold separately.

CHIPSURFER™ 47D_RB HARDWARE

			Tightening Torque (in. lbs.)
	Thin Wrench	Torque Wrench	
47D-3119TQRB02	WS-0043	DT-60-06	60
47D-3725T6RB04	WS-0029	DT-90-08	90
47D-5035T8RB04	WS-0030	DT-130-10	130
47D08004TQRB05	WS-0043	DT-60-06	60
47D10006T6RB10	WS-0029	DT-90-08	90
47D12008T8RB10	WS-0030	DT-130-10	130
47D16011TRRB10	WS-0044	DT-250-13	250



CHIPSURFER™ SERIES 48E_RB: BARREL FORM FINISHER

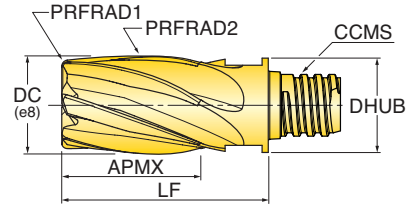

6-FLUTE, 30° HELIX, FOR STEELS AND HI-TEMPS



Part Number	DC Cutting Diameter	PRFRAD1 Profile Radius	PRFRAD2 Profile Radius	APMX Depth of Cut Max.	LF Functional Length	ZEFF Effective Flutes	FHA Flute Helix Angle	CCMS Connection Code	DHUB Hub Diameter
48E12016T8RB271	12.00 mm	0.50 mm	70.00 mm	16.40 mm	27.00 mm	6	30	Chip Surfer T08	11.50 mm
48E16021TRRB342	16.00 mm	0.50 mm	100.00 mm	20.90 mm	33.50 mm	6	30	Chip Surfer T10	15.30 mm

*When assembling, be sure tip is seated firmly on shank with no gap.
No lubricant on adaption.
Wrenches sold separately.

CHIPSURFER™ 48E_RB HARDWARE

	 Thin Wrench	 Torque Wrench <small>**OPTIONAL**</small>	Tightening Torque (in. lbs.)
48E12016T8RB271	WS-0030	DT-130-10	130
48E16021TRRB342	WS-0044	DT-250-13	250

CHIPSURFER™ OPERATING GUIDELINES TAPER FORM

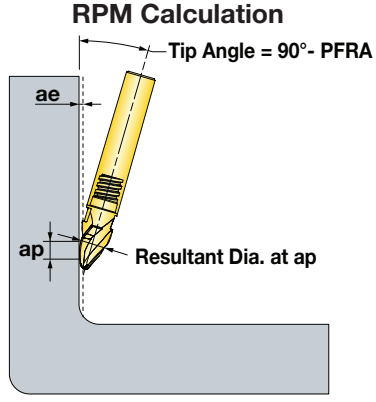

* RPM calculation is to be made using the resultant diameter at ap.

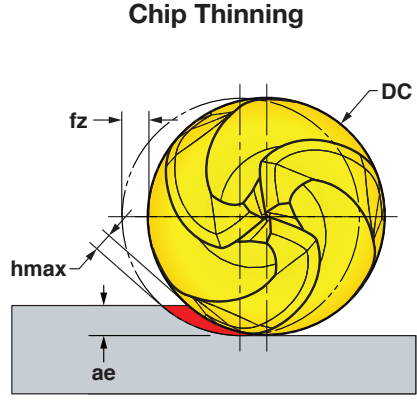

** Chip Thinning Calculator is recommended to ensure hmax is in range.

Materials				Cutting Speed SFM *	DC Cutting Dia. (inch/mm)	fz Feed per Tooth (inch)	ae Radial Cutting Depth	ap* Axial Depth of Cut	hmax** Chip Thickness (inch)	Coolant
ISO	Mat'l Group #VDI 3323	Type	Examples							
P	1 thru 5	Non-alloy Steel	1018, A36, 1045, A572, 1070	450-650	.312" / 8	.0010-.0020	.0015-.0060	.03-.06	.0007-.0015	No
					.375" / 10	.0010-.0025	.0015-.0060		.0007-.0020	
					.500" / 12	.0010-.0030	.0015-.0060		.0007-.0025	
					.625" / 16	.0010-.0040	.0020-.0070		.0007-.0030	
	6 thru 9	Low-alloy Steel	4140, 4340, P20, 8620, 300M	450-650	.312" / 8	.0010-.0020	.0015-.0060	.03-.06	.0007-.0015	
					.375" / 10	.0010-.0025	.0015-.0060		.0007-.0020	
					.500" / 12	.0010-.0030	.0015-.0060		.0007-.0025	
					.625" / 16	.0010-.0040	.0020-.0070		.0007-.0030	
	10, 11	High-alloy Steel	H13, A2, D2, M2, T1	400-600	.312" / 8	.0008-.0015	.0015-.0060	.03-.06	.0007-.0012	
					.375" / 10	.0008-.0025	.0015-.0060		.0007-.0017	
					.500" / 12	.0010-.0030	.0015-.0060		.0007-.0022	
					.625" / 16	.0010-.0040	.0020-.0070		.0007-.0027	
M	12 thru 14	Stainless Steel	410, 416, 440, 303, 304, 316, 15-5, 17-4	200-350	.312" / 8	.0008-.0015	.0015-.0060	.03-.06	.0007-.0012	May be required at high speeds
					.375" / 10	.0008-.0025	.0015-.0060		.0007-.0017	
					.500" / 12	.0010-.0030	.0015-.0060		.0007-.0022	
					.625" / 16	.0010-.0040	.0020-.0070		.0007-.0027	
K	15 thru 20	Iron	CLS. 20, 30, 45, 60-40-18, 100-70-03	500-700	.312" / 8	.0010-.0020	.0015-.0060	.03-.06	.0007-.0015	No
					.375" / 10	.0010-.0025	.0015-.0060		.0007-.0020	
					.500" / 12	.0010-.0030	.0015-.0060		.0007-.0025	
					.625" / 16	.0010-.0040	.0020-.0070		.0007-.0030	
N	21 thru 30	Non ferrous & Plastics	7075, 6061	1000-3000	.312" / 8	.0015-.0025	.0015-.0060	.03-.06	.0007-.0020	Yes
					.375" / 10	.0015-.0030	.0015-.0060		.0007-.0025	
					.500" / 12	.0015-.0035	.0015-.0060		.0007-.0030	
					.625" / 16	.0015-.0045	.0020-.0070		.0007-.0035	
S	31 thru 37	High-Temp, Ti	Inconel, Hastelloy, 6Al-4V, 5Al-5Mo-5V-3Cr	80-250	.312" / 8	.0008-.0015	.0015-.0060	.03-.06	.0007-.0012	Yes
					.375" / 10	.0008-.0025	.0015-.0060		.0007-.0017	
					.500" / 12	.0010-.0030	.0015-.0060		.0007-.0022	
					.625" / 16	.0010-.0040	.0020-.0070		.0007-.0027	

Note: Feed and speed recommendations are starting operating parameters. They are only guidelines from which further optimization should take place. Operating parameters are influenced by many machining variables. These variables may cause for reductions in feeds and speed or dramatic increases. Additionally, DOC and WOC may need to be revised to optimize the tools performance.

CHIPSURFER™ OPERATING GUIDELINES LENS FORM

RPM Calculation

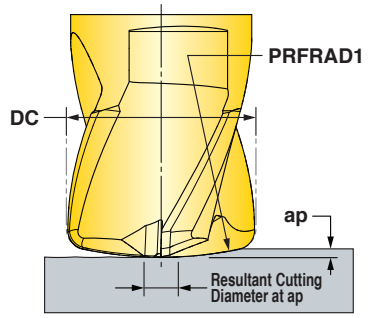

* RPM calculation is to be made using the resultant diameter at ap.

Chip Thinning

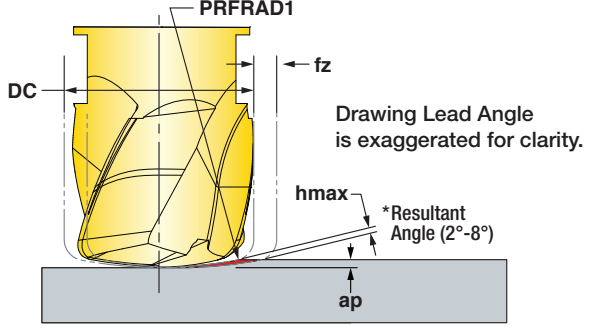

** Chip Thinning Calculator is recommended to ensure hmax is in range.

ISO	Materials			Cutting Speed SFM *	DC Cutting Dia. (inch/mm)	fz Feed per Tooth (inch)	ap Axial Depth of Cut	hmax** Chip Thickness (inch)	Coolant
	Mat'l Group #VDI 3323	Type	Examples						
P	1 thru 5	Non-alloy Steel	1018, A36, 1045, A572, 1070	700-900	.312" / 8	.0020-.0040	.002-.004	.0010-.0030	No
					.375" / 10	.0020-.0040	.002-.004	.0010-.0035	
					.500" / 12	.0020-.0050	.003-.006	.0010-.0040	
					.625" / 16	.0020-.0060	.004-.012	.0010-.0045	
	6 thru 9	Low-alloy Steel	4140, 4340, P20, 8620, 300M	600-700	.312" / 8	.0015-.0030	.002-.004	.0010-.0030	
					.375" / 10	.0015-.0030	.002-.004	.0010-.0035	
					.500" / 12	.0015-.0040	.003-.006	.0010-.0040	
					.625" / 16	.0015-.0050	.004-.012	.0010-.0045	
	10, 11	High-alloy Steel	H13, A2, D2, M2, T1	500-650	.312" / 8	.0010-.0025	.002-.004	.0010-.0025	
					.375" / 10	.0010-.0025	.002-.004	.0010-.0030	
					.500" / 12	.0010-.0030	.003-.006	.0010-.0035	
					.625" / 16	.0010-.0040	.004-.012	.0010-.0040	
M	12 thru 14	Stainless Steel	410, 416, 440, 303, 304, 316, 15-5, 17-4	200-450	.312" / 8	.0010-.0025	.002-.004	.0010-.0025	May be required at high speeds
					.375" / 10	.0010-.0025	.002-.004	.0010-.0030	
					.500" / 12	.0010-.0030	.003-.006	.0010-.0035	
					.625" / 16	.0010-.0040	.004-.012	.0010-.0040	
K	15 thru 20	Iron	CLS. 20, 30, 45, 60-40-18, 100-70-03	600-850	.312" / 8	.0015-.0030	.002-.004	.0010-.0030	No
					.375" / 10	.0015-.0030	.002-.004	.0010-.0035	
					.500" / 12	.0015-.0040	.003-.006	.0010-.0040	
					.625" / 16	.0015-.0050	.004-.012	.0010-.0045	
S	31 thru 37	High-Temp, Ti	Inconel, Hastelloy, 6Al-4V, 5Al-5Mo-5V-3Cr	120-250	.312" / 8	.0010-.0025	.002-.004	.0010-.0025	Yes
					.375" / 10	.0010-.0025	.002-.004	.0010-.0030	
					.500" / 12	.0010-.0030	.003-.006	.0010-.0035	
					.625" / 16	.0010-.0040	.004-.012	.0010-.0040	
					.750" / 20	.0010-.0040	.004-.015	.0010-.0045	

Note: Feed and speed recommendations are starting operating parameters. They are only guidelines from which further optimization should take place. Operating parameters are influenced by many machining variables. These variables may cause for reductions in feeds and speed or dramatic increases. Additionally, DOC and WOC may need to be revised to optimize the tools performance.

CHIPSURFER™ OPERATING GUIDELINES BARREL FORM

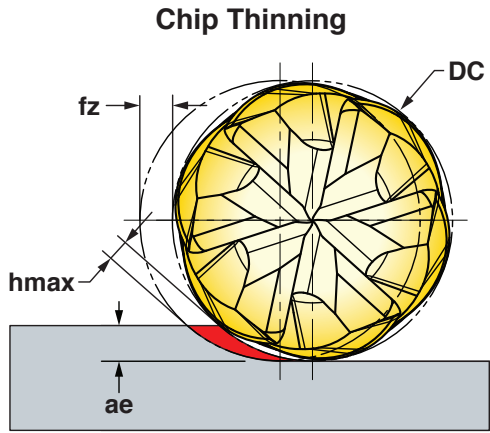

* Chip Thinning Calculator is recommended to ensure hmax is in range.

Materials				Cutting Speed SFM	DC Cutting Dia. (inch/mm)	fz Feed per Tooth (inch)	ae Radial Depth of Cut	ap Axial Depth of Cut	hmax* Chip Thickness (inch)	Coolant
ISO	Mat'l Group #VDI 3323	Type	Examples							
P	1 thru 5	Non-alloy Steel	1018, A36, 1045, A572, 1070	450-650	.500 / 12	.0020-.0040	.008-.016	.03-.06	.0008-.0030	No
					.625 / 16	.0020-.0050	.008-.020	.04-.08	.0008-.0040	
	6 thru 9	Low-alloy Steel	4140, 4340, P20, 8620, 300M	450-650	.500 / 12	.0020-.0040	.008-.016	.03-.06	.0008-.0030	
					.625 / 16	.0020-.0050	.008-.020	.04-.08	.0008-.0040	
	10, 11	High-alloy Steel	H13, A2, D2, M2, T1	400-600	.500 / 12	.0015-.0030	.008-.016	.03-.06	.0008-.0025	
					.625 / 16	.0020-.0040	.008-.020	.04-.08	.0008-.0035	
M	12 thru 14	Stainless Steel	410, 416, 440, 303, 304, 316, 15-5, 17-4	200-350	.500 / 12	.0015-.0030	.008-.016	.03-.06	.0008-.0025	May be required at high speeds
					.625 / 16	.0020-.0040	.008-.020	.04-.08	.0008-.0035	
K	15 thru 20	Iron	CLS. 20, 30, 45, 60-40-18, 100-70-03	500-700	.500 / 12	.0020-.0040	.008-.016	.03-.06	.0008-.0030	No
					.625 / 16	.0020-.0050	.008-.020	.04-.08	.0008-.0040	
S	31 thru 37	High-Temp, Ti	Inconel, Hastelloy, 6Al-4V, 5Al-5Mo-5V-3Cr	80-250	.500 / 12	.0010-.0025	.008-.016	.03-.06	.0008-.0025	Yes
					.625 / 16	.0020-.0030	.008-.020	.04-.08	.0008-.0035	

Note: Feed and speed recommendations are starting operating parameters. They are only guidelines from which further optimization should take place. Operating parameters are influenced by many machining variables. These variables may cause for reductions in feeds and speed or dramatic increases. Additionally, DOC and WOC may need to be revised to optimize the tools performance.

CHIP SURFER™ INDEXING CHIP SURFER TIPS

- Step 1: Screw tip into shank until finger tight (Figure 1a). Note a .010" gap (Figure 1b).
- Step 2: Use wrench to torque approximately 1/4 turn, creating a simultaneous fit (Figure 2).
- Step 3: Use .001" shim stock to check the simultaneous fit at the intersection of the tip and the shank.
The shim should not be able to enter the intersection (Figure 3a).
If it does, tighten further with the wrench until there is no gap (Figure 3b).

Note: Pre-set torque wrenches (series DT- . . .) can be purchased.

