



DIPOSPENTA™

MILLING PRODUCTS



Cutter Series (Depth of Cut):

Hi-Feed: 1DP1C / DP6C (.06)

Hi-Feed: 1DP1P / DP6P (.11)

65° Lead: DM6C (.13)

65° Lead: DM6P (.25)

Insert Series:

PNCU05

PNCU10

Diameter Range:

.750" - 4.00"

Lead Angles:

25° & 65°

Adaptions:

Cylindrical, Top-On
& Face Mill

Materials:

Cast Iron, Steel, Stainless Steels,
Super Alloys

Hi-Feed & 65° Mills with 10-Edge Economy!

In response to the market's demand for Hi-Feed cutters with economical multi-corner inserts while adding further value to utilize the same insert for deeper facing applications, Ingersoll announces DiPosPenta. Available with two different insert sizes, DiPosPenta incorporates 2-Side-Technology with positive-geometry-performance in mind. Whereas the Hi-Feed cutters aim for .06 & .12 DOC's respectively, the 65° Face mills combine the chip thinning benefits of 45° with deeper depth of 75°.

Features & Benefits:

- Same insert fits Hi-Feed & 65° mills
- Reinforced cutting edge boasts high feed rate potential
- Positive geometry promotes smooth machining
- Wide market range including Die/Mold and General Purpose!

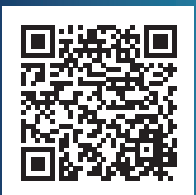

FEATURES

Same insert covers both high feed and facing applications

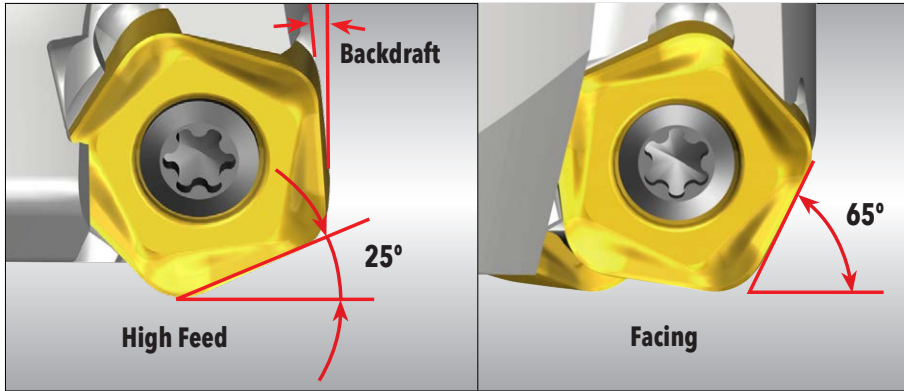

Lower cutting force in deep cavity machining (High Feed)

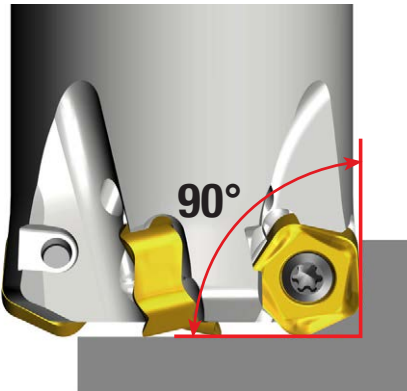

High positive rake angle for smooth machining (High Feed)

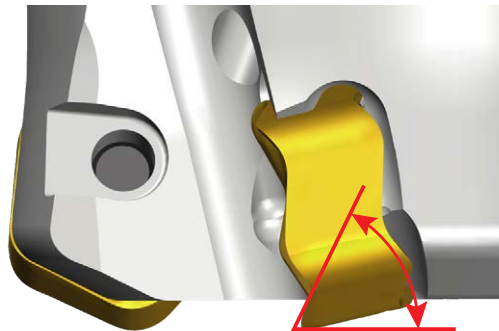



DIOSPENTA™ 05 SERIES 1DP1C (CYLINDRICAL SHANK STYLE)

HI-FEED END MILL (5MM INSERT)

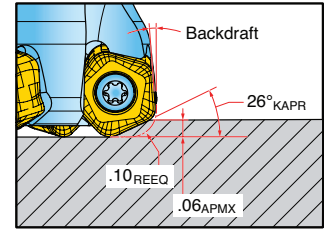
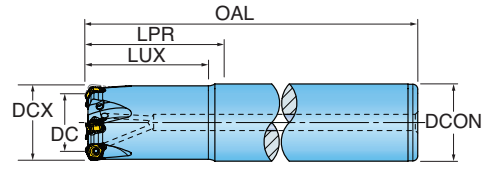
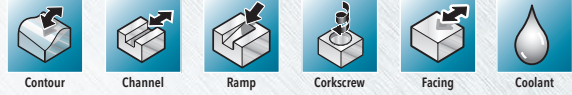

Part Number	DCX Cutting Dia. Max.	DC Cutting Dia.	LUX Usable Length Max.	LPR Protruding Length	OAL Overall Length	ZEFF Eff. Teeth	REEQ Program Radius Equivalent	DCON Shank Dia.	RMPX Ramp Angle Max.
1DP1C-07015S7R01	0.750	0.431	1.50	4.00	6.00	3	0.100	0.750	1.3
1DP1C-10015S1R01	1.000	0.677	1.50	3.75	6.00	4	0.100	1.000	1.1
1DP1C-12020S9R01	1.250	0.927	2.00	5.75	8.00	5	0.100	1.250	1
1DP1C-15020S5R01	1.500	1.177	2.00	5.34	8.00	6	0.100	1.500	0.8

*Program like an end mill with .10" Corner Radius.

DIOSPENTA™ 05 SERIES 1DP1C (TOP-ON STYLE)

HI-FEED MODULAR END MILL (5MM INSERT)

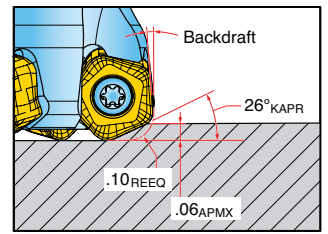
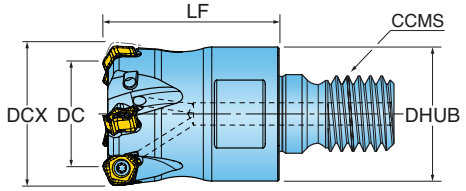

Part Number	DCX Cutting Dia. Max.	DC Cutting Diameter	LF Functional Length	ZEFF Effective Teeth	REEQ Program Radius Equivalent	CCMS Connection Code	RMPX Ramp Angle Max.
1DP1C-07015X6R01	0.750	0.431	1.50	3	0.100	TopOn M10	1.3
1DP1C-10015X7R01	1.000	0.677	1.50	4	0.100	TopOn M12	1.1
1DP1C-12015X8R01	1.250	0.927	1.50	5	0.100	TopOn M16	1
1DP1C-15015X8R01	1.500	1.177	1.50	6	0.100	TopOn M16	0.8

*Program like an end mill with .10" Corner Radius.



DIOSPENTA™ 05 SERIES DP6C

HI-FEED FACE MILL (5MM INSERT)

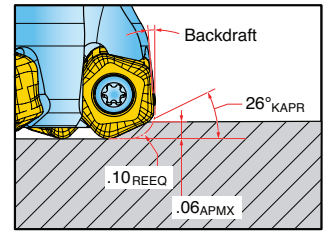
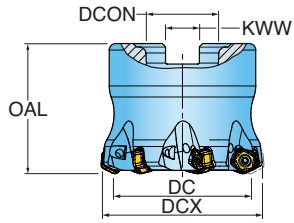

Part Number	DCX Cutting Dia. Max.	DC Cutting Diameter	OAL Overall Length	ZEFF Effective Teeth	REEQ Program Radius Equivalent	DCON Bore Dia.	KWW Keyway	RMPX Ramp Angle Max.
DP6C-15R01	1.500	1.177	1.57	6	0.100	0.500	0.25	0.8
DP6C-20R01	2.000	1.677	1.57	7	0.100	0.750	0.31	0.7
DP6C-25R01	2.500	2.177	1.57	8	0.100	0.750	0.31	0.6

*Programing Corner Radius: .10"R.

DIOSPENTA™ 05 SERIES DM6C

65° FACE MILL (5MM INSERT)

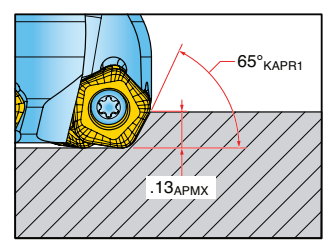
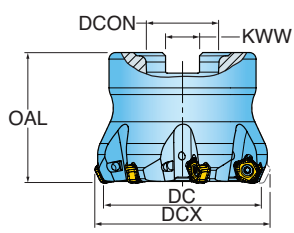

Part Number	DCX Cutting Dia. Max.	DC Cutting Diameter	OAL Overall Length	ZEFF Effective Teeth	DCON Bore Dia.	KWW Keyway
DM6C-15R01	1.500	1.65	1.570	6	0.500	0.250
DM6C-20R01	2.000	2.15	1.570	7	0.750	0.312
DM6C-25R01	2.500	2.65	1.570	8	0.750	0.312
DM6C-30R01	3.000	3.15	1.750	9	1.000	0.375



DIOSPENTA™ 05 INSERT



Part Number	Application	RE Corner Radius	IC Inscribed Circle Dia.	S Thickness	NOI Number of Indexes	IH Insert Hand	Grade	IN2505	IN2530	IN2036
PNCU050315R-M	Multi-Purpose	0.059	0.279	0.149	10	Right		•	•	
PNCU050315R-ML	SS/Hi-Temp/Ti	0.059	0.279	0.149	10	Right		•	•	•

DIOSPENTA™ 05 HARDWARE

	Screw	Torx Driver	Retention Bolt	**OPTIONAL** Coolant Retention Bolt	**OPTIONAL** Torque Driver Handle	**OPTIONAL** Preset Torque Bit	**OPTIONAL** Torque Driver Bit	**OPTIONAL** Wrench
1DP1C-0701557R01	SM25-060-90	DS-TP07S	-	-	DS-A00-.25-S	DT-08-.25	DS-TP07B1	-
1DP1C-1001551R01	SM25-060-90	DS-TP07S	-	-	DS-A00-.25-S	DT-08-.25	DS-TP07B1	-
1DP1C-1202059R01	SM25-060-90	DS-TP07S	-	-	DS-A00-.25-S	DT-08-.25	DS-TP07B1	-
1DP1C-1502055R01	SM25-060-90	DS-TP07S	-	-	DS-A00-.25-S	DT-08-.25	DS-TP07B1	-
1DP1C-07015X6R01	SM25-060-90	DS-TP07S	-	-	DS-A00-.25-S	DT-08-.25	DS-TP07B1	615MM
1DP1C-10015X7R01	SM25-060-90	DS-TP07S	-	-	DS-A00-.25-S	DT-08-.25	DS-TP07B1	617MM
1DP1C-12015X8R01	SM25-060-90	DS-TP07S	-	-	DS-A00-.25-S	DT-08-.25	DS-TP07B1	622MM
1DP1C-15015X8R01	SM25-060-90	DS-TP07S	-	-	DS-A00-.25-S	DT-08-.25	DS-TP07B1	622MM
DP6C-15R01	SM25-060-90	DS-TP07S	SD-04-46	-	DS-A00-.25-S	DT-08-.25	DS-TP07B1	-
DP6C-20R01	SM25-060-90	DS-TP07S	SD-06-46	SD-06-89	DS-A00-.25-S	DT-08-.25	DS-TP07B1	-
DP6C-25R01	SM25-060-90	DS-TP07S	SD-06-46	SD-06-89	DS-A00-.25-S	DT-08-.25	DS-TP07B1	-
DM6C-15R01	SM25-060-90	DS-TP07S	SD-04-46	-	DS-A00-.25-S	DT-08-.25	DS-TP07B1	-
DM6C-20R01	SM25-060-90	DS-TP07S	SD-06-46	SD-06-89	DS-A00-.25-S	DT-08-.25	DS-TP07B1	-
DM6C-25R01	SM25-060-90	DS-TP07S	SD-06-46	SD-06-89	DS-A00-.25-S	DT-08-.25	DS-TP07B1	-
DM6C-30R01	SM25-060-90	DS-TP07S	SD-08-46	SD08-C9	DS-A00-.25-S	DT-08-.25	DS-TP07B1	-



DIOSPENTA™ 10 SERIES 1DP1P (CYLINDRICAL SHANK STYLE)

HI-FEED END MILL (10MM INSERT)

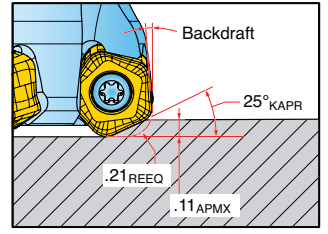
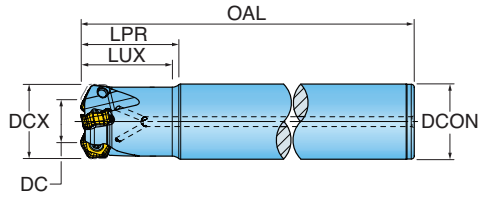
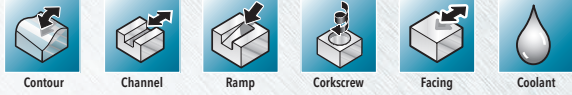

Part Number	DCX Cutting Dia. Max.	DC Cutting Dia.	APMX Depth of Cut Max.	LUX Usable Length Max.	LPR Protruding Length	OAL Overall Length	ZEFF Eff. Teeth	REEQ Program Radius Equivalent	DCN Shank Dia.	RMPX Ramp Angle Max.
1DP1P-15020S5R01	1.500	0.850	0.118	2.00	5.34	8.00	3	0.210	1.500	2.2

*Program like an end mill with .21" Corner Radius.

DIOSPENTA™ 10 SERIES 1DP1P (TOP•ON STYLE)

HI-FEED MODULAR END MILL (10MM INSERT)

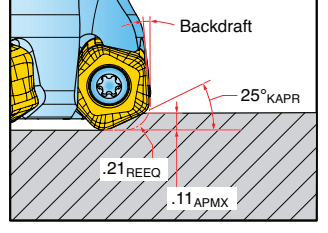
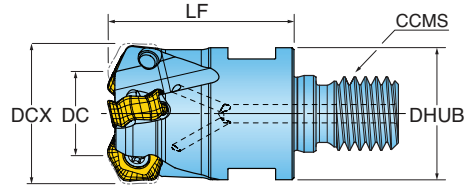

Part Number	DCX Cutting Dia. Max.	DC Cutting Dia.	APMX Depth of Cut Max.	LF Functional Length	ZEFF Eff. Teeth	REEQ Program Radius Equivalent	DHUB Hub Dia.	CCMS Connection Code	RMPX Ramp Angle Max.
1DP1P-15020X9R01	1.500	0.850	0.118	2.00	3	0.210	1.41	TopOn M20	2.2

*Program like an end mill with .21" Corner Radius.



DIOSPENTA™ 10 SERIES DP6P

HI-FEED FACE MILL (10MM INSERT)

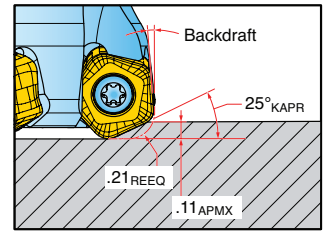
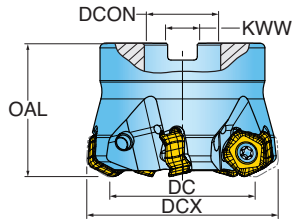

Part Number	DCX Cutting Dia. Max.	DC Cutting Diameter	OAL Overall Length	ZEFF Effective Teeth	REEQ Program Radius Equivalent	DCON Bore Dia.	KWW Keyway	RMPX Ramp Angle Max.
DP6P-20R01	2.000	1.350	1.57	4	0.210	0.750	0.31	2.5
DP6P-25R01	2.500	1.850	1.75	5	0.210	1.000	0.38	1.6
DP6P-30R01	3.000	2.350	1.75	6	0.210	1.000	0.38	1.2

* Programing Corner Radius: .21"R.

DIOSPENTA™ 10 SERIES DM6P

65° FACE MILL (10MM INSERT)

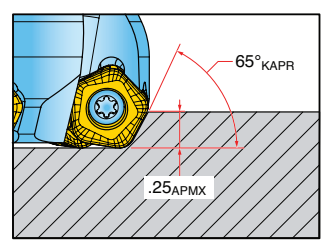
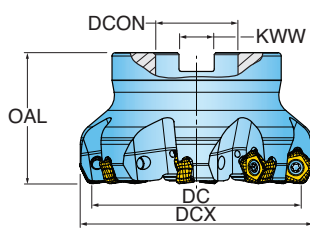

Part Number	DC Cutting Diameter	DCX Cutting Dia. Max.	OAL Overall Length	ZEFF Effective Teeth	DCON Bore Dia.	KWW Keyway
DM6P-20R01	2.000	2.280	1.750	4	1.000	0.375
DM6P-25R01	2.500	2.780	1.750	5	1.000	0.375
DM6P-30R01	3.000	3.280	1.750	6	1.000	0.375
DM6P-40R01	4.000	4.280	2.375	8	1.500	0.625



DIOSPENTA™ 10 INSERT

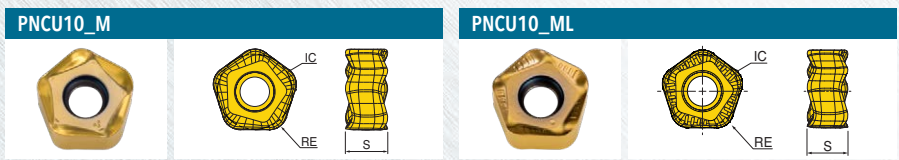

Part Number	Application	RE Corner Radius	IC Inscribed Circle Dia.	S Thickness	NOI Number of Indexes	IH Insert Hand	Grade	IN2505	IN2530	IN2036
PNCU100630R-M	Multi-Purpose	0.118	0.559	0.303	10	Right		•	•	
PNCU100630R-ML	SS/Hi-Temp/Ti	0.118	0.559	0.303	10	Right		•	•	•

DIOSPENTA™ 10 HARDWARE

	Screw	Driver Handle	Torx Driver Blade	Retention Bolt	Retention Bolt	Torque Driver Handle	Preset Torque Bit	Torque Driver Bit	Wrench
1DP1P-15020S5R01	SM50-127-10	DS-A00T	DS-T206B	-	-	DS-A00-.25-T	DT-44-.25	DS-T20B1	-
1DP1P-15020X9R01	SM50-127-10	DS-A00T	DS-T206B	-	-	DS-A00-.25-T	DT-44-.25	DS-T20B1	630MM
DP6P-20R01	SM50-127-10	DS-A00T	DS-T206B	SD-06-46	SD-06-89	DS-A00-.25-T	DT-44-.25	DS-T20B1	-
DP6P-25R01	SM50-127-10	DS-A00T	DS-T206B	SD-08-47	SD08-C9	DS-A00-.25-T	DT-44-.25	DS-T20B1	-
DP6P-30R01	SM50-127-10	DS-A00T	DS-T206B	SD-08-47	SD08-C9	DS-A00-.25-T	DT-44-.25	DS-T20B1	-
DM6P-20R01	SM50-127-10	DS-A00T	DS-T206B	SD-08-47	SD08-C9	DS-A00-.25-T	DT-44-.25	DS-T20B1	-
DM6P-25R01	SM50-127-10	DS-A00T	DS-T206B	SD-08-47	SD08-C9	DS-A00-.25-T	DT-44-.25	DS-T20B1	-
DM6P-30R01	SM50-127-10	DS-A00T	DS-T206B	SD-08-47	SD08-C9	DS-A00-.25-T	DT-44-.25	DS-T20B1	-
DM6P-40R01	SM50-127-10	DS-A00T	DS-T206B	SD-12-82	SD-12-99	DS-A00-.25-T	DT-44-.25	DS-T20B1	-



DIOSPENTA™ 05 OPERATING GUIDELINES (65°)

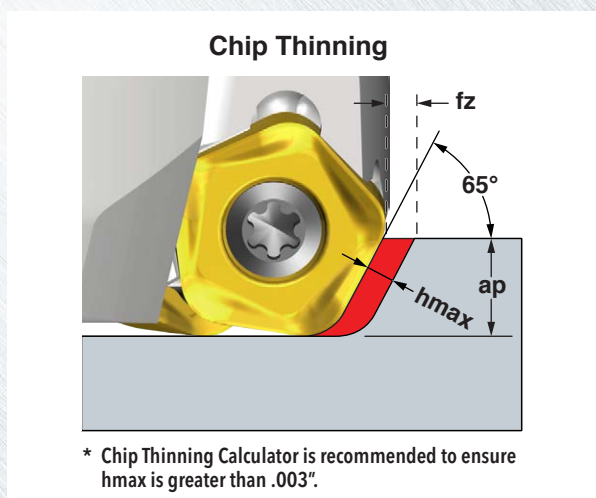

ISO	Materials			Vc Cutting Speed SFM	fz* Feed/Tooth (inch)	ap Recommended Axial Depth of Cut (inch)	Harder Tougher			Coolant
	Mat'l Group #VDI 3323	Type	Examples				IN2505	IN2530	IN2036	
P	1 thru 5	Non-alloy Steel	1018, A36, 1045, A572, 1070	400-1000						
	6 thru 9	Low-alloy Steel	4140, 4340, P20, 8620, 300M	350-700	.004-.008	.040-.120	2	1		No
	10, 11	High-alloy Steel	H13, A2, D2, M2, T1	300-600						
M	12 - 13	Stainless Steel (ferritic & martensitic)	410, 416, 440	350-600	.004-.007	.040-.120	3	2	1	Yes
	14	Stainless Steel (austenitic)	303, 304, 316, 15-5, 17-4	300-550						May not be required at high speeds
K	15 thru 16	Gray Cast Iron	CLS. 20, 30, 45	500-1000	.004-.008	.040-.120	1	2		No
	17 thru 20	Nodular Cast Iron	60-40-18, 100-70-03	400-800						
S	31 - 35	High-Temp Alloys	Inconel, Hastelloy, Nimonic, Monel	65-120	.004-.007	.040-.120	2	3	1	Yes
	36 - 37	Titanium Alloys	6Al-4V, 5Al-5Mo-5V-3Cr	85-130						

Note: Feed and speed recommendations are starting operating parameters. They are only guidelines from which further optimization should take place. Operating parameters are influenced by many machining variables. These variables may cause for reductions in feeds and speed or dramatic increases. Additionally, DOC and WOC may need to be revised to optimize the tools performance.



DIOSPENTA™ 05 OPERATING GUIDELINES (HI-FEED)

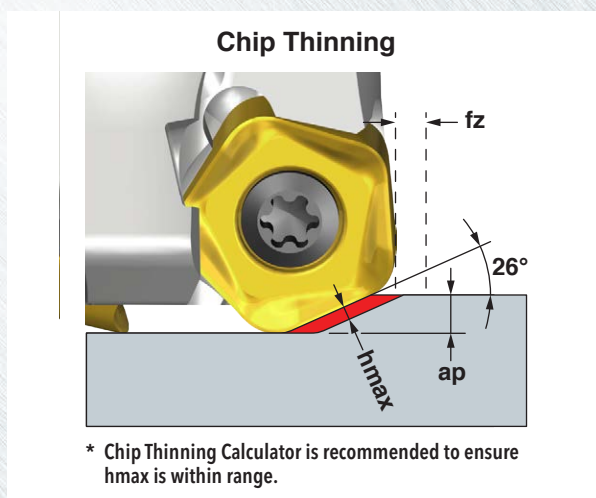

ISO	Materials			Vc Cutting Speed SFM	fz* Feed/Tooth (inch)	ap Rec. Axial Depth of Cut (inch)	hmax* Chip Thickness (inch)	Harder Tougher			Coolant
	Mat'l Group #VDI 3323	Type	Examples					IN2505	IN2530	IN2036	
P	1 thru 5	Non-alloy Steel	1018, A36, 1045, A572, 1070	400-1000	.008-.030	.008-.060	.003-.013	2	1		No
	6 thru 9	Low-alloy Steel	4140, 4340, P20, 8620, 300M	350-700							
	10, 11	High-alloy Steel	H13, A2, D2, M2, T1	300-600							
M	12 - 13	Stainless Steel (ferritic & martensitic)	410, 416, 440	350-600	.008-.025	.008-.060	.003-.011	3	2	1	Yes
	14	Stainless Steel (austenitic)	303, 304, 316, 15-5, 17-4	300-550							May not be required at high speeds
K	15 thru 16	Gray Cast Iron	CLS. 20, 30, 45	500-1000	.008-.030	.008-.060	.003-.013	1	2		No
	17 thru 20	Nodular Cast Iron	60-40-18, 100-70-03	400-800							
S	31 - 35	High-Temp Alloys	Inconel, Hastelloy, Nimonic, Monel	65-120	.008-.025	.008-.060	.003-.011	2	3	1	Yes
	36 - 37	Titanium Alloys	6Al-4V, 5Al-5Mo-5V-3Cr	85-130							

Note: Feed and speed recommendations are starting operating parameters. They are only guidelines from which further optimization should take place. Operating parameters are influenced by many machining variables. These variables may cause for reductions in feeds and speed or dramatic increases. Additionally, DOC and WOC may need to be revised to optimize the tools performance.



DIOSPENTA™ 10 OPERATING GUIDELINES (65°)

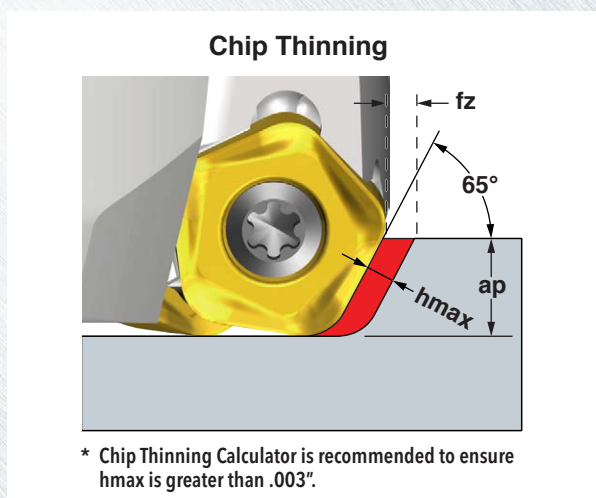

ISO	Materials			Vc Cutting Speed SFM	fz* Feed/Tooth (inch)	ap Recommended Axial Depth of Cut (inch)	Harder Tougher			Coolant
	Mat'l Group #VDI 3323	Type	Examples				IN2505	IN2530	IN2036	
P	1 thru 5	Non-alloy Steel	1018, A36, 1045, A572, 1070	400-1000	.004-.010	.060-.200	2	1		No
	6 thru 9	Low-alloy Steel	4140, 4340, P20, 8620, 300M	350-700						
	10, 11	High-alloy Steel	H13, A2, D2, M2, T1	300-600						
M	12 - 13	Stainless Steel (ferritic & martensitic)	410, 416, 440	350-600	.004-.009	.060-.200	3	2	1	Yes
	14	Stainless Steel (austenitic)	303, 304, 316, 15-5, 17-4	300-550						
K	15 thru 16	Gray Cast Iron	CLS. 20, 30, 45	500-1000	.004-.010	.060-.200	1	2		No
	17 thru 20	Nodular Cast Iron	60-40-18, 100-70-03	400-800						
S	31 - 35	High-Temp Alloys	Inconel, Hastelloy, Nimonic, Monel	65-120	.004-.008	.060-.200	2	3	1	Yes
	36 - 37	Titanium Alloys	6Al-4V, 5Al-5Mo-5V-3Cr	85-130						

Note: Feed and speed recommendations are starting operating parameters. They are only guidelines from which further optimization should take place. Operating parameters are influenced by many machining variables. These variables may cause for reductions in feeds and speed or dramatic increases. Additionally, DOC and WOC may need to be revised to optimize the tools performance.



DIOSPENTA™ 10 OPERATING GUIDELINES (HI-FEED)

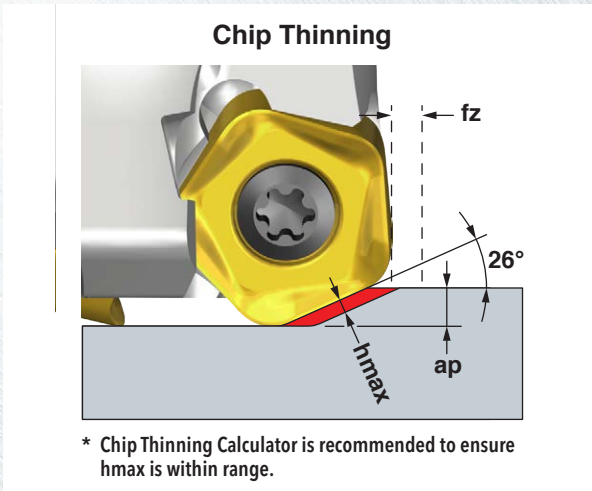

ISO	Materials			Vc Cutting Speed SFM	fz* Feed/Tooth (inch)	ap Rec. Axial Depth of Cut (inch)	hmax* Chip Thickness (inch)	Harder Tougher			Coolant
	Mat'l Group #VDI 3323	Type	Examples					IN2505	IN2530	IN2036	
P	1 thru 5	Non-alloy Steel	1018, A36, 1045, A572, 1070	400-1000	.008-.035	.008-.080	.003-.015	2	1		No
	6 thru 9	Low-alloy Steel	4140, 4340, P20, 8620, 300M	350-700							
	10, 11	High-alloy Steel	H13, A2, D2, M2, T1	300-600							
M	12 - 13	Stainless Steel (ferritic & martensitic)	410, 416, 440	350-600	.008-.030	.008-.080	.003-.013	3	2	1	Yes
	14	Stainless Steel (austenitic)	303, 304, 316, 15-5, 17-4	300-550							May not be required at high speeds
K	15 thru 16	Gray Cast Iron	CLS. 20, 30, 45	500-1000	.008-.035	.008-.080	.003-.015	1	2		No
	17 thru 20	Nodular Cast Iron	60-40-18, 100-70-03	400-800							
S	31 - 35	High-Temp Alloys	Inconel, Hastelloy, Nimonic, Monel	65-120	.008-.030	.008-.080	.003-.013	2	3	1	Yes
	36 - 37	Titanium Alloys	6Al-4V, 5Al-5Mo-5V-3Cr	85-130							3

Note: Feed and speed recommendations are starting operating parameters. They are only guidelines from which further optimization should take place. Operating parameters are influenced by many machining variables. These variables may cause for reductions in feeds and speed or dramatic increases. Additionally, DOC and WOC may need to be revised to optimize the tools performance.

DIOSPENTA™ 05 RAMP DATA USING SERIES PNCU05 (HI-FEED)

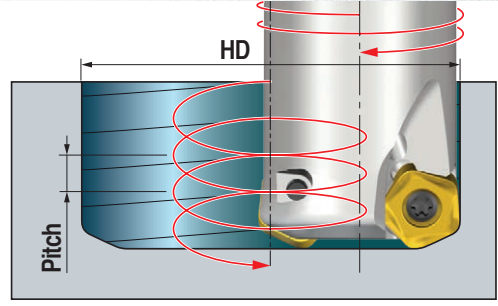
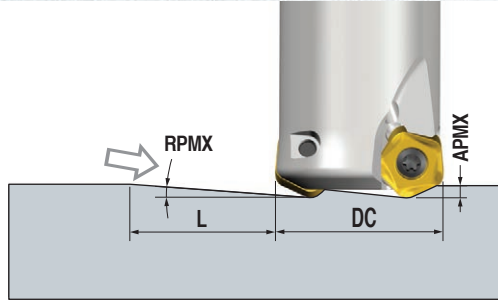

DC Cutter Diameter	Straight Ramp			Helical Ramp		
	RMPX Ramp Angle Max.	APMX Depth of Cut Max.	L Ramp Length Min.	HD Hole Diameter Min.	HD Hole Diameter Max.	Pitch Max.
0.750	1.2	.060	2.5	1.23	1.50	.027
						.035
1.000	1.0	.060	3.3	1.73	2.00	.031
						.035
1.250	1.0	.060	3.3	2.23	2.50	.039
						.043
1.500	0.8	.060	3.9	2.73	3.00	.043
						.047
2.000	0.7	.060	4.8	3.73	4.00	.047
						.051
2.500	0.6	.060	5.1	4.73	5.00	.051
						.055

DIOSPENTA™ 05 PROGRAMMING DATA: PNCU05 (HI-FEED)

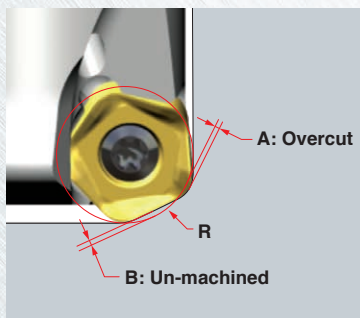

Insert Number	R Program	A Over cut	B Un-machined
PNCU 05	.100	0	.032
	.106	0	.030
	.118	.001	.026

 : Recommended program 'R'

DIPOSPENTA™ 10 RAMP DATA USING SERIES PNCU10 (HI-FEED)

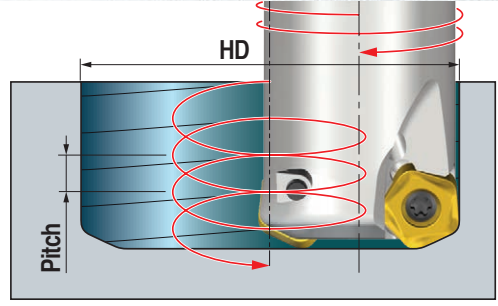
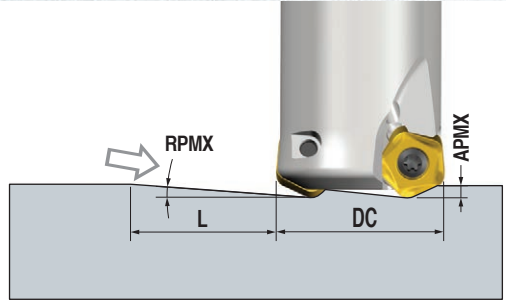

DC Cutter Diameter	Straight Ramp			Helical Ramp		
	RMPX Ramp Angle Max.	APMX Depth of Cut Max.	L Ramp Length Min.	HD Hole Diameter Min.	HD Hole Diameter Max.	Pitch Max.
1.500	1.5	.118	4.3	2.33	3.00	.067
						.086
2.000	1.9	.118	3.4	3.33	4.00	.110
						.118
2.500	1.7	.118	3.9	4.33	5.00	.118
						.118
3.000	1.5	.118	4.5	5.33	6.00	.118
						.118

DIPOSPENTA™ 10 PROGRAMMING DATA: PNCU10 (HI-FEED)

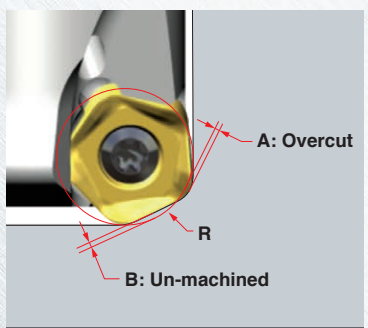

Insert Number	R Program	A Over cut	B Un-machined
PNCU 10	.216	0	.057
	.236	.003	.050
	.256	.008	.044

Yellow background: Recommended program 'R'