



MULTISURFER™

MILLING PRODUCTS



Tip Style Series:

T-Slot: 18T, 19T, 19R NEW

Facing: 18F, 19F

Thread: 18Y, 19Y

Diameter (Connection Code):

0.97" / 25mm (LP)

1.25" / 32mm (LQ)

1.56" / 40mm (LR)

Shank Adaptions:

Cylindrical

Materials:

Cast Iron, Steel, Stainless Steel,
High-Temp Alloys & Titanium

Quick-Change Interchangeable Solid Carbide Heads for Slotting, Facing & Threading

Multi-Surfer is a replaceable head system for larger diameter solid carbide slotting, facing and single point threading. It bridges a diameter gap between Ingersoll's popular Chip-Surfer and Indexable Slotters. To oppose the cutting forces that accompany larger diameters, Multi-Surfer is equipped with a unique and simple design that allows for precise and rigid mounting.

Features & Benefits:

- .970-1.560 T-Slot heads with .125-.375 width range and 6-10 flutes
- 1.560 Full radius T-Slot heads with .062-.312 width range and 10 flutes
- 24-39mm Facing heads with 6-10 flutes; Ideal for stubby applications
- 60° Partial Profile Thread heads with 6-10 flutes
- Cylindrical shanks with strong Bore, Screw & Tri-Lobe-Drive connection
- Steel shanks with various configurations and coolant options

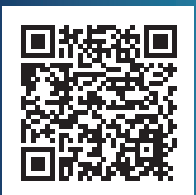

FEATURES

Stable, Secure Drive Adaption

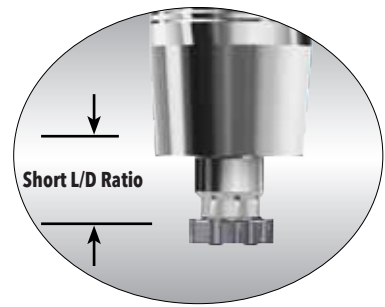
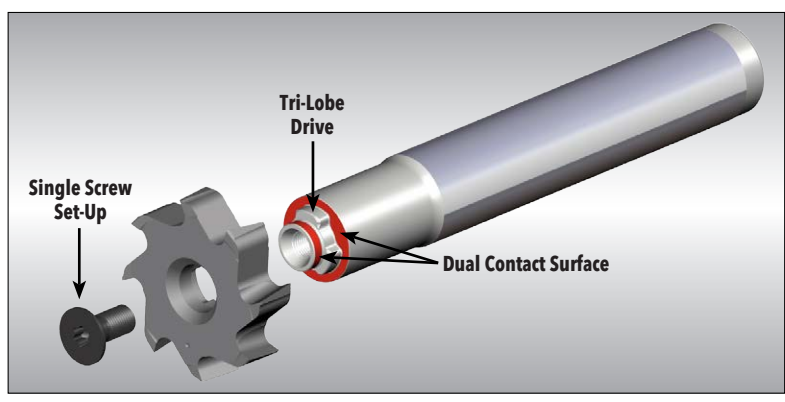

More Cutting Edges Maximize Productivity

Indexable
Low Density



MULTISURFER
High Density



Coolant Alignment

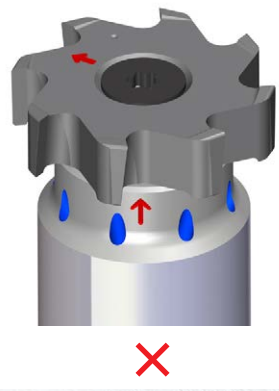
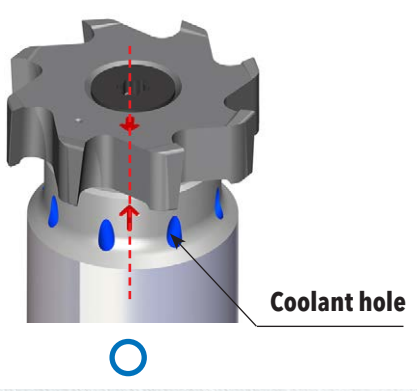

When internal coolant is applied by combining the 18F/19F head with the S-L-SA holder, the arrows shown on the head and holder must be positioned opposite to each other (as shown below) in order to ensure a smooth coolant flow to the cutting edge.



MULTISURFER™ SIZE RANGES

Slotting 18T/19T/19R

Tool diameter (inch/mm)	CW Cutting Width (inch/mm)	CDX Cutting Depth (inch/mm)
.970" / 24.7mm	.12-.31" / 3-8mm	.21" / 5.5mm
1.250" / 31.7mm	.12-.31" / 3-8mm	.31" / 8mm
1.562" / 39.7mm	.062-.37" / 4-10mm	.39" / 11mm

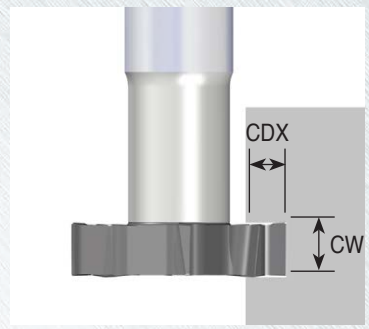

Facing 18F/19F

Tool diameter (mm)	APMX Depth of Cut Max. (mm)	Number of teeth
25	8	6
32	8	8
40	10	10

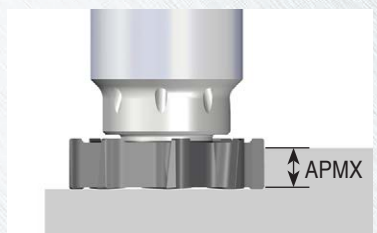

Threading 18Y/19Y

Tool diameter (mm)	Screw profile	Number of teeth
24.7	M60	6
31.7	M60	8
39.7	M60	10



MULTISURFER™ SERIES 18T, 19T

T-SLOT TIP

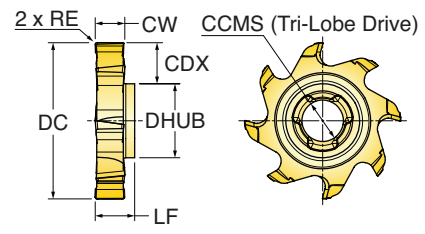
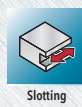

Part Number	DC Cutting Diameter	RE Corner Radius	CW Cutting Width	CDX Cutting Depth Max.	LF Functional Length	ZEFF Eff. Teeth	CCMS Connection Code	DHUB Hub Diameter	Grade
									IN2005
18T-9712LPRN01	0.970	0.015 R	0.125	0.210	0.315	6	Multi-Surfer LP	0.510	•
18T-9715LPRN01	0.970	0.015 R	0.156	0.210	0.315	6	Multi-Surfer LP	0.510	•
18T-9718LPRN01	0.970	0.015 R	0.187	0.210	0.315	6	Multi-Surfer LP	0.510	•
18T-9721LPRN01	0.970	0.015 R	0.218	0.210	0.315	6	Multi-Surfer LP	0.510	•
18T-9725LPRN01	0.970	0.015 R	0.250	0.210	0.315	6	Multi-Surfer LP	0.510	•
18T-9728LPRN01	0.970	0.015 R	0.281	0.210	0.315	6	Multi-Surfer LP	0.510	•
18T-9731LPRN01	0.970	0.015 R	0.312	0.210	0.315	6	Multi-Surfer LP	0.510	•
19T-1212LQRN01	1.250	0.015 R	0.125	0.310	0.315	8	Multi-Surfer LQ	0.590	•
19T-1215LQRN01	1.250	0.015 R	0.156	0.310	0.315	8	Multi-Surfer LQ	0.590	•
19T-1218LQRN01	1.250	0.015 R	0.187	0.310	0.315	8	Multi-Surfer LQ	0.590	•
19T-1221LQRN01	1.250	0.015 R	0.218	0.310	0.315	8	Multi-Surfer LQ	0.590	•
19T-1225LQRN01	1.250	0.015 R	0.250	0.310	0.315	8	Multi-Surfer LQ	0.590	•
19T-1228LQRN01	1.250	0.015 R	0.281	0.310	0.315	8	Multi-Surfer LQ	0.590	•
19T-1231LQRN01	1.250	0.015 R	0.312	0.310	0.315	8	Multi-Surfer LQ	0.590	•
19T-1515LRRN01	1.562	0.015 R	0.156	0.430	0.394	10	Multi-Surfer LR	0.670	•
19T-1518LRRN01	1.562	0.015 R	0.187	0.430	0.394	10	Multi-Surfer LR	0.670	•
19T-1521LRRN01	1.562	0.015 R	0.218	0.430	0.394	10	Multi-Surfer LR	0.670	•
19T-1525LRRN01	1.562	0.015 R	0.250	0.430	0.394	10	Multi-Surfer LR	0.670	•
19T-1528LRRN01	1.562	0.015 R	0.281	0.430	0.394	10	Multi-Surfer LR	0.670	•
19T-1531LRRN01	1.562	0.015 R	0.312	0.430	0.394	10	Multi-Surfer LR	0.670	•
19T-1537LRRN01	1.562	0.015 R	0.375	0.430	0.394	10	Multi-Surfer LR	0.670	•

MULTISURFER™ SERIES 18T, 19T (METRIC)

T-SLOT TIP

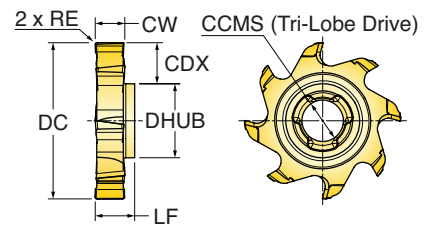
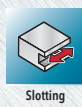

Part Number	DC Cutting Diameter	RE Corner Radius	CW Cutting Width	CDX Cutting Depth Max.	LF Functional Length	ZEFF Eff. Teeth	CCMS Connection Code	DHUB Hub Diameter	Grade
									IN2005
18T24730LPRN04	24.70 mm	0.400 R	3.00 mm	5.50 mm	8.00 mm	6	Multi-Surfer LP	13.00 mm	•
18T24740LPRN04	24.70 mm	0.400 R	4.00 mm	5.50 mm	8.00 mm	6	Multi-Surfer LP	13.00 mm	•
18T24750LPRN04	24.70 mm	0.400 R	5.00 mm	5.50 mm	8.00 mm	6	Multi-Surfer LP	13.00 mm	•
18T24760LPRN04	24.70 mm	0.400 R	6.00 mm	5.50 mm	8.00 mm	6	Multi-Surfer LP	13.00 mm	•
18T24770LPRN04	24.70 mm	0.400 R	7.00 mm	5.50 mm	8.00 mm	6	Multi-Surfer LP	13.00 mm	•
18T24780LPRN04	24.70 mm	0.400 R	8.00 mm	5.50 mm	8.00 mm	6	Multi-Surfer LP	13.00 mm	•
19T31730LQRN04	31.70 mm	0.400 R	3.00 mm	8.00 mm	8.00 mm	8	Multi-Surfer LQ	15.00 mm	•
19T31740LQRN04	31.70 mm	0.400 R	4.00 mm	8.00 mm	8.00 mm	8	Multi-Surfer LQ	15.00 mm	•
19T31750LQRN04	31.70 mm	0.400 R	5.00 mm	8.00 mm	8.00 mm	8	Multi-Surfer LQ	15.00 mm	•
19T31760LQRN04	31.70 mm	0.400 R	6.00 mm	8.00 mm	8.00 mm	8	Multi-Surfer LQ	15.00 mm	•
19T31770LQRN04	31.70 mm	0.400 R	7.00 mm	8.00 mm	8.00 mm	8	Multi-Surfer LQ	15.00 mm	•
19T31780LQRN04	31.70 mm	0.400 R	8.00 mm	8.00 mm	8.00 mm	8	Multi-Surfer LQ	15.00 mm	•
19T39740LRRN04	39.70 mm	0.400 R	4.00 mm	11.00 mm	10.00 mm	10	Multi-Surfer LR	17.00 mm	•
19T39750LRRN04	39.70 mm	0.400 R	5.00 mm	11.00 mm	10.00 mm	10	Multi-Surfer LR	17.00 mm	•
19T39760LRRN04	39.70 mm	0.400 R	6.00 mm	11.00 mm	10.00 mm	10	Multi-Surfer LR	17.00 mm	•
19T39770LRRN04	39.70 mm	0.400 R	7.00 mm	11.00 mm	10.00 mm	10	Multi-Surfer LR	17.00 mm	•
19T39780LRRN04	39.70 mm	0.400 R	8.00 mm	11.00 mm	10.00 mm	10	Multi-Surfer LR	17.00 mm	•
19T39790LRRN04	39.70 mm	0.400 R	9.00 mm	11.00 mm	10.00 mm	10	Multi-Surfer LR	17.00 mm	•
19T39799LRRN04	39.70 mm	0.400 R	10.00 mm	11.00 mm	10.00 mm	10	Multi-Surfer LR	17.00 mm	•

MULTISURFER™ SERIES 19R

FULL RADIUS ALL-EFFECTIVE T-SLIT TIP

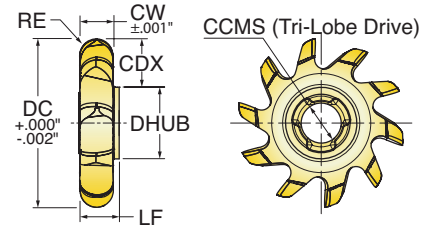
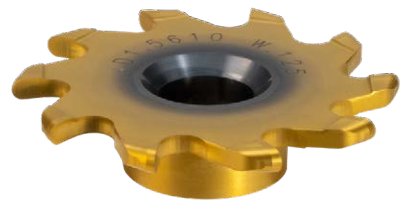

Part Number	DC Cutting Diameter	RE/CHW Corner Radius/ Chamfer Width	CW Cutting Width	CDX Cutting Depth Max.	LF Functional Length	ZEFF Eff. Teeth	CCMS Connection Code	DHUB Hub Diameter	Grade
									IN2505
NEW 19RE1506LRRN03	1.562	0.031 R	0.062	0.430	0.390	10	Multi-Surfer LR	0.670	•
NEW 19RE1509LRRN04	1.562	0.047 R	0.094	0.430	0.390	10	Multi-Surfer LR	0.670	•
NEW 19RE1512LRRN06	1.562	0.062 R	0.125	0.430	0.390	10	Multi-Surfer LR	0.670	•
NEW 19RE1515LRRN07	1.562	0.078 R	0.156	0.430	0.393	10	Multi-Surfer LR	0.670	•
NEW 19RE1518LRRN09	1.562	0.094 R	0.187	0.430	0.389	10	Multi-Surfer LR	0.670	•

MULTISURFER™ SERIES 19R

FULL RADIUS STAGGER TOOTH T-SLOT TIP

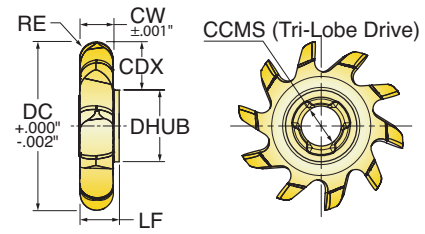
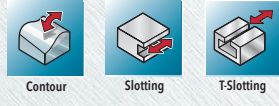

Part Number	DC Cutting Diameter	RE/CHW Corner Radius/ Chamfer Width	CW Cutting Width	CDX Cutting Depth Max.	LF Functional Length	ZEFF Eff. Teeth	CCMS Connection Code	DHUB Hub Diameter	Grade
									IN2505
NEW 19RE1525LRRN12	1.562	0.125 R	0.250	0.430	0.382	10	Multi-Surfer LR	0.670	•
NEW 19RE1531LRRN15	1.562	0.156 R	0.312	0.430	0.366	10	Multi-Surfer LR	0.670	•



MULTISURFER™ SERIES 18F, 19F (METRIC)

90° FACE MILL TIP

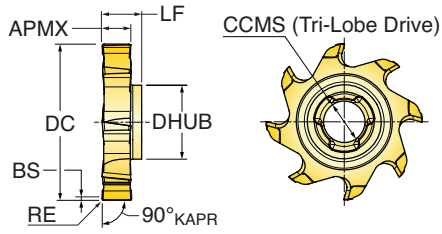

Part Number	DC Cutting Diameter	RE Corner Radius	BS Wiper Length	APMX Depth of Cut Max.	LF Functional Length	ZEFF Eff. Teeth	CCMS Connection Code	DHUB Hub Diameter	Grade
									IN2005
18F24280LPRA04	25.00 mm	0.400 R	3.60 mm	8.00 mm	8.0 mm	8	Multi-Surfer LP	13.0 mm	•
19F31280LQRA04	32.00 mm	0.400 R	3.60 mm	8.00 mm	8.0 mm	8	Multi-Surfer LQ	15.0 mm	•
19F39210LRR04	40.00 mm	0.400 R	3.60 mm	10.00 mm	10.0 mm	10	Multi-Surfer LR	17.0 mm	•

MULTISURFER™ SERIES 18Y_60, 19Y_60

PARTIAL PROFILE THREAD MILL TIP

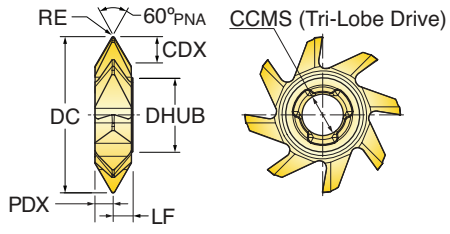
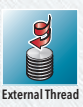

Part Number	DC Cutting Dia.	TPN Thread Pitch Min.	TPX Thread Pitch Max.	TPIN Thread Pitch Inch Min.	TPIX Thread Pitch Inch Max.	PNA Profile Included Angle	RE Corner Radius	PDX Profile Distance Ex.	CDX Cutting Depth Max.	LF Functional Length.	DWN Workpiece Dia. Min.	ZEFF Eff. Flutes	CCMS Connection Code	DHUB Hub Diameter	Grade
															IN2005
18Y24730LPRP60	24.70mm	3.0	5.0	8	5	60	0.20mm	2.2mm	3.50mm	5.50mm	36.0mm	6	Multi-Surfer LP	13.0mm	•
19Y31740LQRP60	31.70mm	4.0	6.0	6	4	60	0.30mm	3.7mm	4.70mm	4.00mm	46.0mm	8	Multi-Surfer LQ	15.0mm	•
19Y39760LRRP60	39.70mm	6.0	8.0	4	3	60	0.40mm	4.5mm	6.20mm	5.00mm	57.0mm	10	Multi-Surfer LR	17.0mm	•



MULTISURFER™ SERIES S*L*SA

STEEL SHANK, NECKED

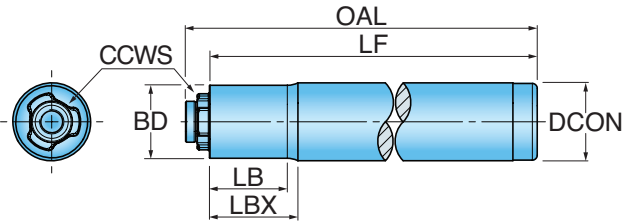

Part Number	CCWS Connection Code	LB Body Length 1	LBX Body Length Max.	LF Functional Length	OAL Overall Length	BD Body Diameter	DCON Shank Diameter	BMC Body Material Code
INCH								
S062LPSA-05	Multi-Surfer LP	0.600"	0.650"	4.000"	4.170"	0.510"	0.625"	Steel
S062LQSA-06	Multi-Surfer LQ	0.700"	0.720"	4.000"	4.190"	0.590"	0.625"	Steel
S062LQSA-07	Multi-Surfer LQ	0.780"	0.800"	5.000"	5.190"	0.590"	0.625"	Steel
S075LRSA-08	Multi-Surfer LR	0.900"	0.940"	5.500"	5.730"	0.670"	0.750"	Steel
METRIC								
S016LPSA-16	Multi-Surfer LP	13.00 mm	16.60 mm	100.00 mm	104.35 mm	13.00 mm	16.00 mm	Steel
S016LQSA-18	Multi-Surfer LQ	16.00 mm	18.20 mm	100.00 mm	104.90 mm	15.00 mm	16.00 mm	Steel
S016LQSA-19	Multi-Surfer LQ	16.00 mm	18.20 mm	130.00 mm	134.90 mm	15.00 mm	16.00 mm	Steel
S020LRSA-23	Multi-Surfer LR	20.20 mm	23.80 mm	140.00 mm	146.00 mm	17.00 mm	20.00 mm	Steel

*Shank modifications can be made by cutting off the back to desired length or turning back the neck for more usable length.



MULTISURFER™ SERIES S*L*SA

STEEL SHANK

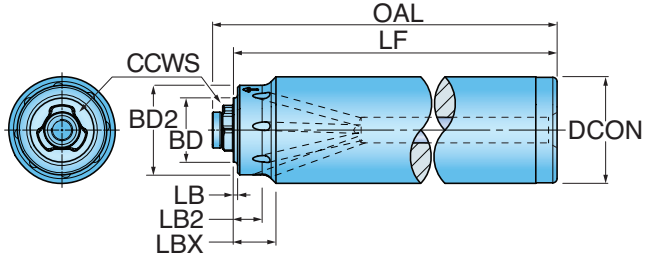

Part Number	CCWS Connection Code	LB Body Length 1	LB2 Body Length 2	LBX Body Length Max.	LF Functional Length	OAL Overall Length	BD Body Dia.	BD2 Body Dia. 2	DCON Shank Dia.	CNSC Coolant Entry Style Code	CXSC Coolant Exit Style Code	BMC Body Mat'l Code
-------------	----------------------	------------------	-------------------	----------------------	----------------------	--------------------	--------------	-----------------	-----------------	-------------------------------	------------------------------	---------------------

INCH

S075LPSA-03	Multi-Surfer LP	0.030"	0.300"	0.380"	4.250"	4.420"	0.510"	0.625"	0.750"	1	1, 3	Steel
S100LQSA-03	Multi-Surfer LQ	0.030"	0.300"	0.380"	4.250"	4.440"	0.590"	0.812"	1.000"	1	1, 3	Steel
S125LRSA-03	Multi-Surfer LR	0.030"	0.300"	0.380"	5.750"	5.980"	0.670"	1.125"	1.250"	1	1, 3	Steel

METRIC

S020LPSA-10	Multi-Surfer LP	0.76 mm	7.60 mm	10.00 mm	100.00 mm	104.35 mm	13.00 mm	16.00 mm	20.00 mm	1	1, 3	Steel
S025LQSA-10	Multi-Surfer LQ	0.76 mm	7.60 mm	10.00 mm	100.00 mm	104.90 mm	15.00 mm	21.00 mm	25.00 mm	1	1, 3	Steel
S032LRSA-10	Multi-Surfer LR	0.76 mm	7.60 mm	10.00 mm	140.00 mm	146.00 mm	17.00 mm	28.00 mm	32.00 mm	1	1, 3	Steel

*Shank modifications can be made by cutting off the back to desired length.

MULTISURFER™ HARDWARE



Screw

Driver Handle

Torx Bit

S062LPSA-05	TS40T098/HG-P	DS-A00T	DS-TP156B
S062LQSA-06	TS50T110/HG-P	DS-A00T	DS-TP206B
S062LQSA-07	TS50T110/HG-P	DS-A00T	DS-TP206B
S075LRSA-08	TS60T130/HG-P	DS-A00T	DS-TP206B
S016LPSA-16	TS40T098/HG-P	DS-A00T	DS-TP156B
S016LQSA-18	TS50T110/HG-P	DS-A00T	DS-TP206B
S016LQSA-19	TS50T110/HG-P	DS-A00T	DS-TP206B
S020LRSA-23	TS60T130/HG-P	DS-A00T	DS-TP206B
S075LPSA-03	TS40T098/HG-P	DS-A00T	DS-TP156B
S100LQSA-03	TS50T110/HG-P	DS-A00T	DS-TP206B
S125LRSA-03	TS60T130/HG-P	DS-A00T	DS-TP206B
S020LPSA-10	TS40T098/HG-P	DS-A00T	DS-TP156B
S025LQSA-10	TS50T110/HG-P	DS-A00T	DS-TP206B
S032LRSA-10	TS60T130/HG-P	DS-A00T	DS-TP206B

MULTISURFER™ OPERATING GUIDELINES

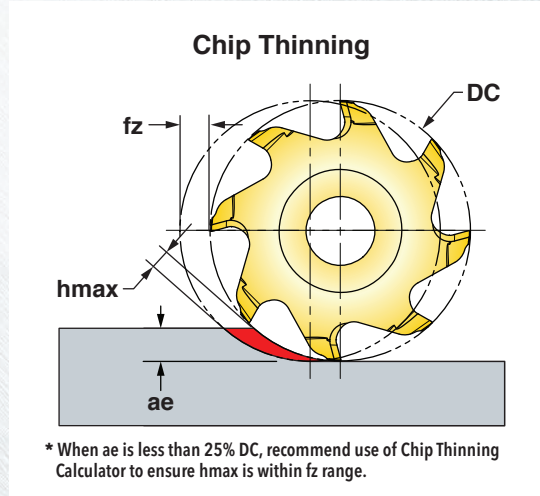

Materials				Vc Cutting Speed SFM	fz* Feed/Tooth (inch)	Coolant
ISO	Mat'l Group #VDI 3323	Type	Examples			
P	1 thru 5	Non-alloy Steel	1018, A36, 1045, A572, 1070	450-650	.002-.007	No
	6 thru 9	Low-alloy Steel	4140, 4340, P20, 8620, 300M	450-650		
	10, 11	High-alloy Steel	H13, A2, D2, M2, T1	400-600		
M	12 thru 13	Stainless Steel (Fer- ritic & Martensitic)	410, 416, 440	200-450	.002-.005	Yes
	14	Stainless Steel (Austenitic)	303, 304, 316, 15-5, 17-4			May not be required at high speeds
K	15 thru 16	Gray Cast Iron	CLS. 20, 30, 45	500-800	.002-.008	No
	17 thru 20	Nodular Cast Iron	60-40-18, 100-70-03			
S	31 thru 35	High-Temp Alloys	Inconel, Hastelloy, Nimonic, Monel	65-150	.002-.005	Yes
	36 thru 37	Titanium Alloys	6Al-4V, 5Al-5Mo-5V-3Cr			

Note: Feed and speed recommendations are starting operating parameters. They are only guidelines from which further optimization should take place. Operating parameters are influenced by many machining variables. These variables may cause for reductions in feeds and speed or dramatic increases. Additionally, DOC and WOC may need to be revised to optimize the tools performance.