

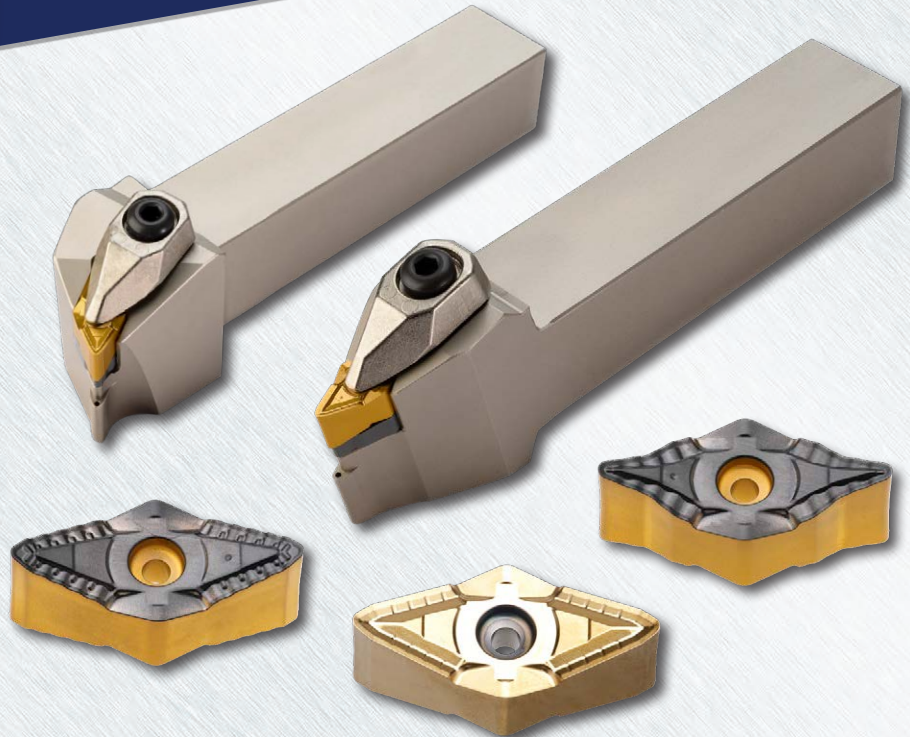

SUPERTURNZ™

TURNING PRODUCTS



Number of Cutting Edges

4

Inserts

ZNMV-BM: 80° insert

ZNMV-BS: 80° insert

ZNMV-Y-BF: 35° included angle

Feed Rates

Forward Turning: .008"~.024"

Backward Turning: .008"~.040"

Cutting Depths

Forward Turning: .010"~.080"

Backward Turning: .010"~.100"

Grades

TT8105, TT8115, TT8125

CVD-coated for steel

TT3010, TT3020

PVD coated for stainless steel,
high temp alloys

Holders

1.00" & 1.25"

Left, Right & Neutral

With or without thru coolant

4-Edge Inserts and Holders for All-Directional Turning Including High Feed Backward Turning

SuperTurnZ is an innovative system for multi-directional turning that utilizes the front and back cutting edge of a 4-corner insert in a single tool. It represents a highly productive alternative to conventional turning where the insert is fed in the same direction, and instead utilizes all 4 directions available on a conventional 2-axis lathe (+z, -z, +x, -x) to maximize material removal.

Features & Benefits:

- Multi-directional turning capabilities that include forward longitudinal turning, high feed backward turning, face turning, profiling and undercutting all with the same tool
- Double-sided ZNMV inserts provide 4 cutting edges
- Insert/holder system uses the same axial and radial rake angle as comparable positive inserts, resulting in low cutting forces
- Serrated cutting edge provides excellent chip control at a variety of cutting depths
- Much higher productivity due to reduced downtime, fewer tool changes and optimized tool paths
- 1.00" and 1.25" holders feature rigid T-Type clamping and optional internal coolant supply



SUPERTURNZ™ KEY POINTS

Conventional turning requires most tools to move in one direction, then be exchanged to go in the opposite direction. As a result, productivity decreases due to tool changes and inefficient tool paths. Ingersoll has solved this problem with the release of an innovative line of ZNMV inserts and corresponding holders capable of turning and facing operations in both forward and backward directions.

The double-sided SuperTurnZ inserts have the same axial & radial rake angle and capability as standard positive inserts, allowing for low cutting forces, but with double the number of cutting edges. The system is a multi-functional, flexible line capable of all directional turning, facing, profiling and undercut machining without the need to change tools. Moreover, a small lead angle for back turning provides an impressive high feed option, up to .040 ipr, that enables much higher productivity.

Inserts are available in three chip breaker types: BM for general purpose in steel, BS for super alloy and low carbon steel and BF for finishing in steel, all of which are compatible with TZQNR/L handed holders. SuperTurnZ is also an excellent alternative to standard VBMT inserts and SVVBN neutral holders when using the BF insert and TZXNN holder, doubling the number of cutting edges while still offering impressive feed rate capabilities. All holders use Ingersoll's traditional T-Type clamping which provides strong clamping force in a user-friendly design.

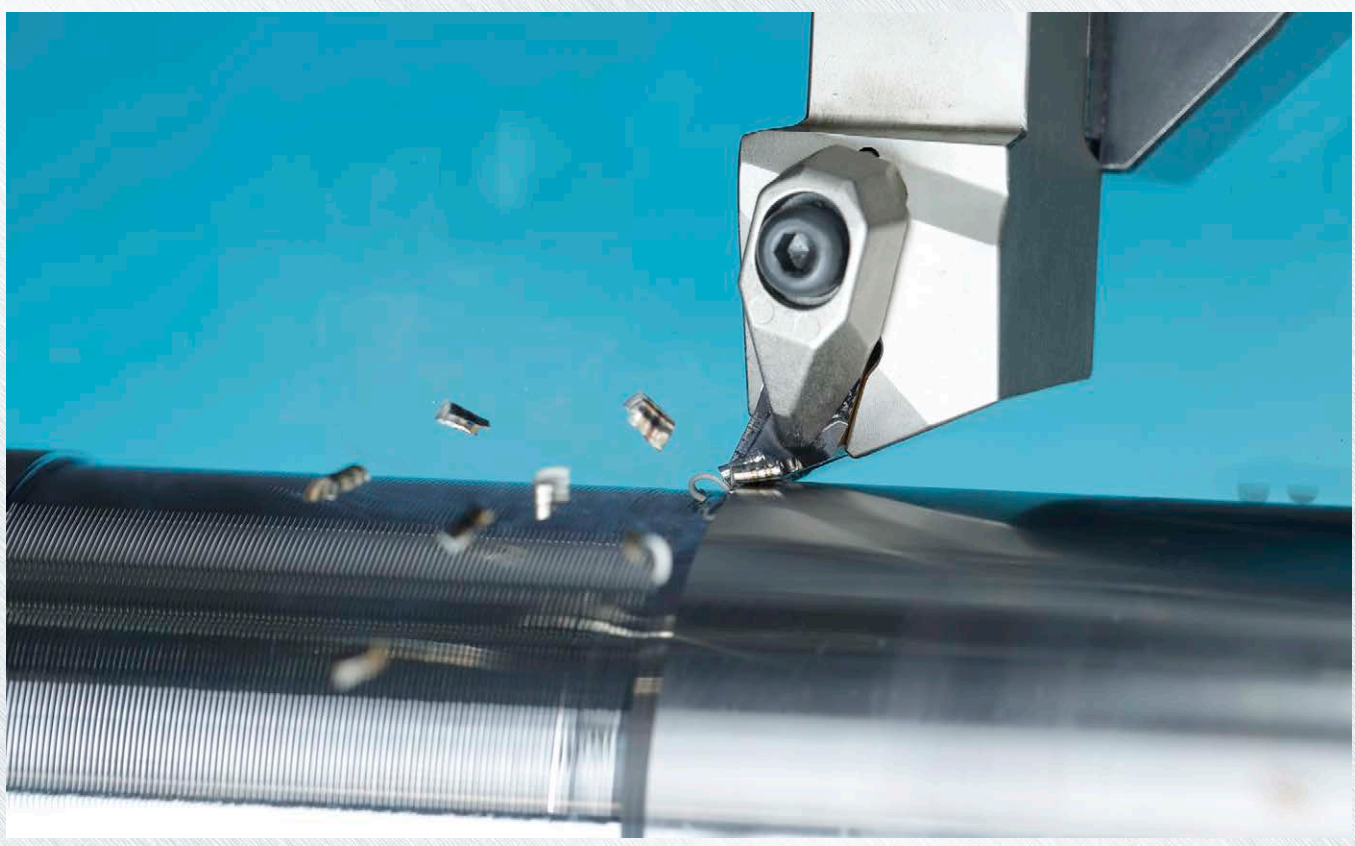

SUPERTURNZ™ CUTTING EDGE ANGLE COMPARISON

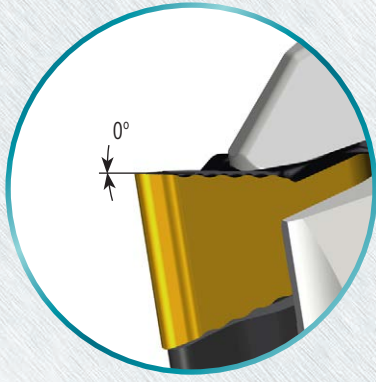

Cutting edge angle of a SuperTurnZ insert

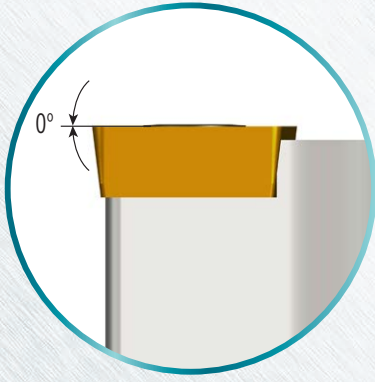

Cutting edge angle of a standard positive insert

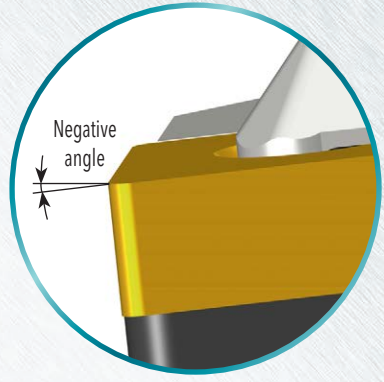

Cutting edge angle of a standard negative insert

SUPERTURNZ™ T-TYPE CLAMPING DESIGN

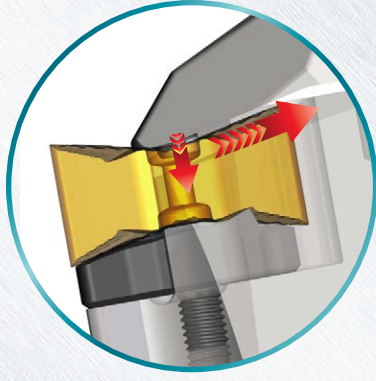

Strong multidirectional clamping force



SUPERTURNZ™ COOLBURST™ HIGH PRESSURE COOLANT HOLDER

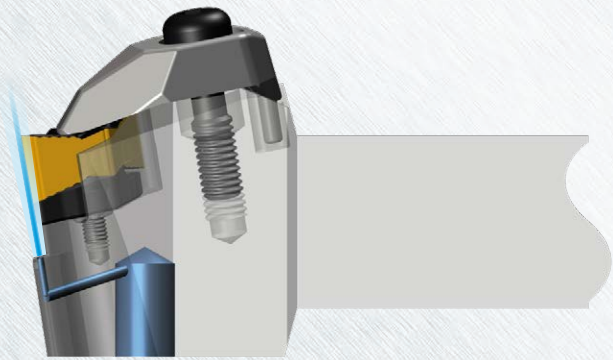

Stable and long tool life

SUPERTURNZ™ ZNMV-BM INSERT GEOMETRY

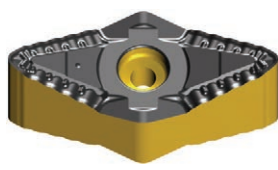
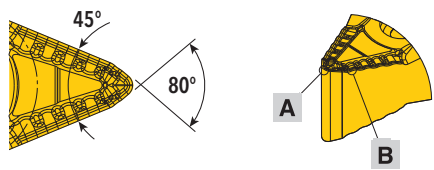
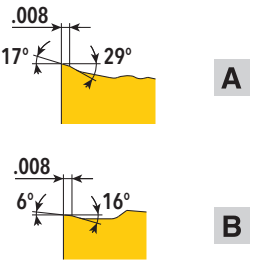
Material	Chip breaker	Cutting edge geometry
P		
S		

SUPERTURNZ™ -BM APPLICATION RANGE

Application range of ZNMV-BM insert with TZQNL holder - Capable of all directional turning.

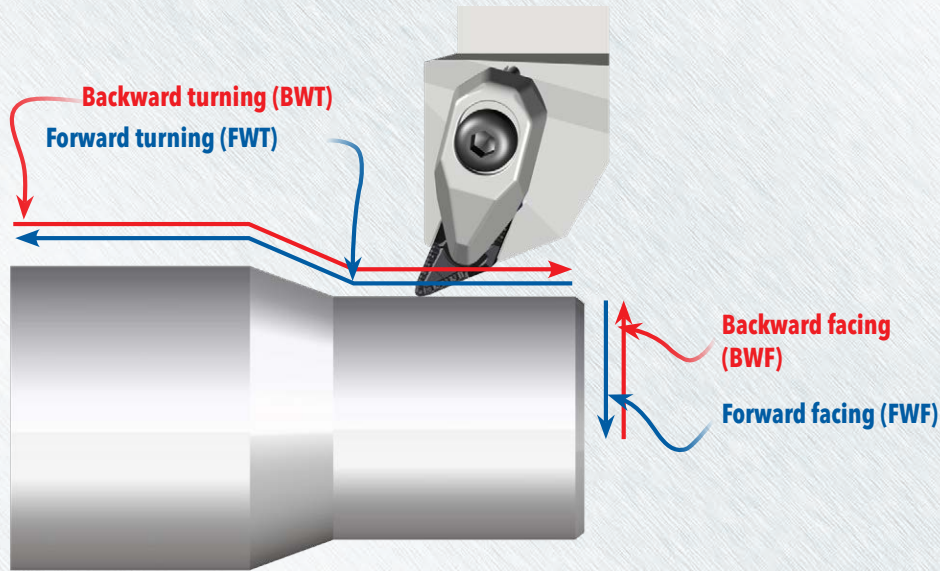

	BWT Backward Turning	BWF Backward Facing	FWT Forward Turning	FWF Forward Facing
f_{Min} (ipr)	.016	.016	.008	.008
$f_{Recom.}$ (ipr)	.028	.028	.012	.012
f_{Max} (ipr)	.040	.040	.024	.024
ap_{Min} (inch)	.020	.020	.020	.020
$ap_{Recom.}$ (inch)	.060	.040	.060	.060
ap_{Max} (inch)	.100	.047	.080	.080

• Capable of profile turning. Capable of high feed turning in BWT and BWF.

SUPERTURNZ™ -BM BACKWARD TURNING

TZQNL holder's **backward** turning (BWT) and ZNMV-BM's chip control range

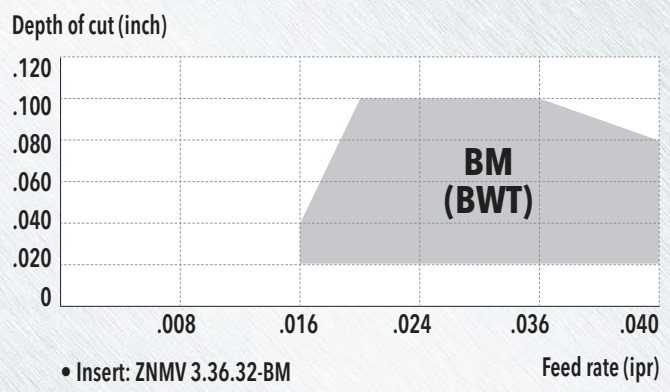
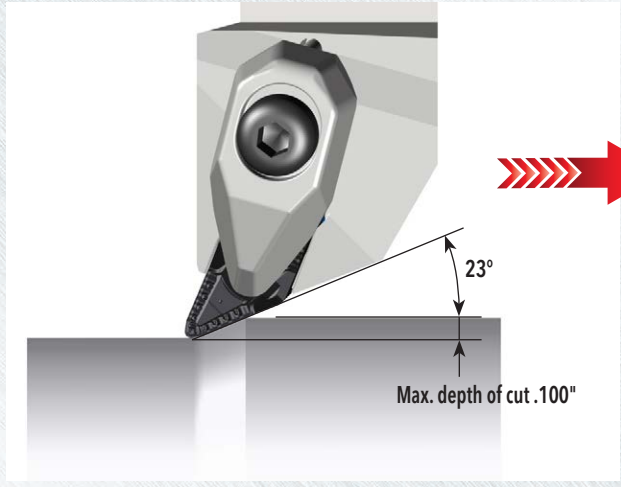

- Insert: ZNMV 3.36.32-BM
- Cutting speed (V): 650 sfm
- Material: AISI 4140 (HB230-260)

SUPERTURNZ™ -BM FORWARD TURNING

TZQNL holder's **forward** turning (FWT) and ZNMV-BM's chip control range

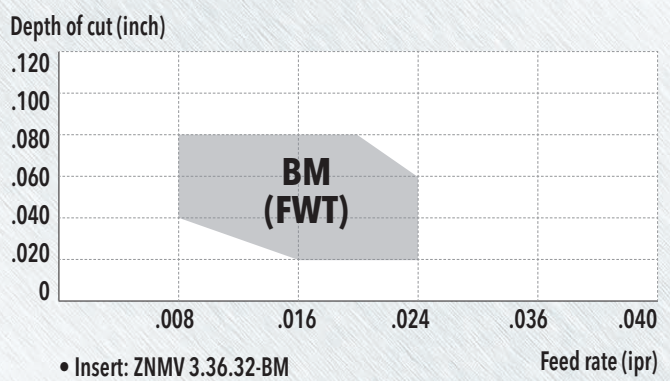
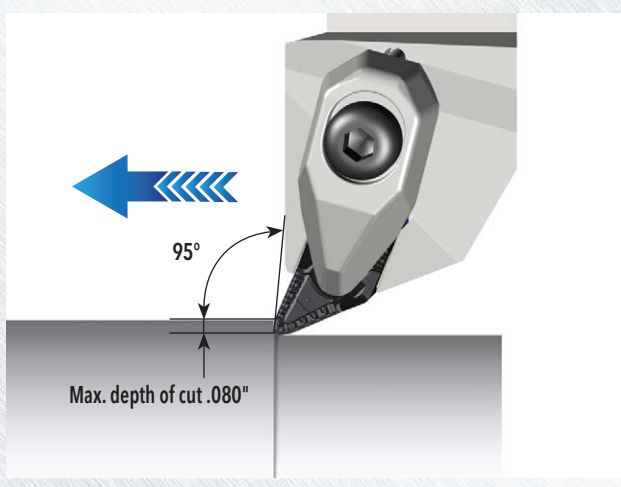

- Insert: ZNMV 3.36.32-BM
- Cutting speed (V): 650 sfm
- Material: AISI 4140 (HB230-260)

SUPERTURNZ™ ZNMV-BS INSERT GEOMETRY

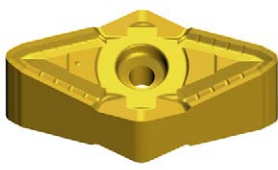
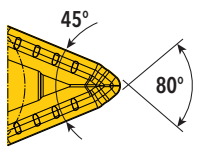
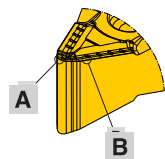
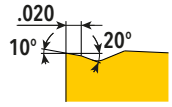
Material	Chip breaker	Cutting edge geometry	
P			
S			
			 <p>B</p>

SUPERTURNZ™ -BS APPLICATION RANGE

Application range of ZNMV-BS insert with TZQNL holder - Capable of all directional turning.

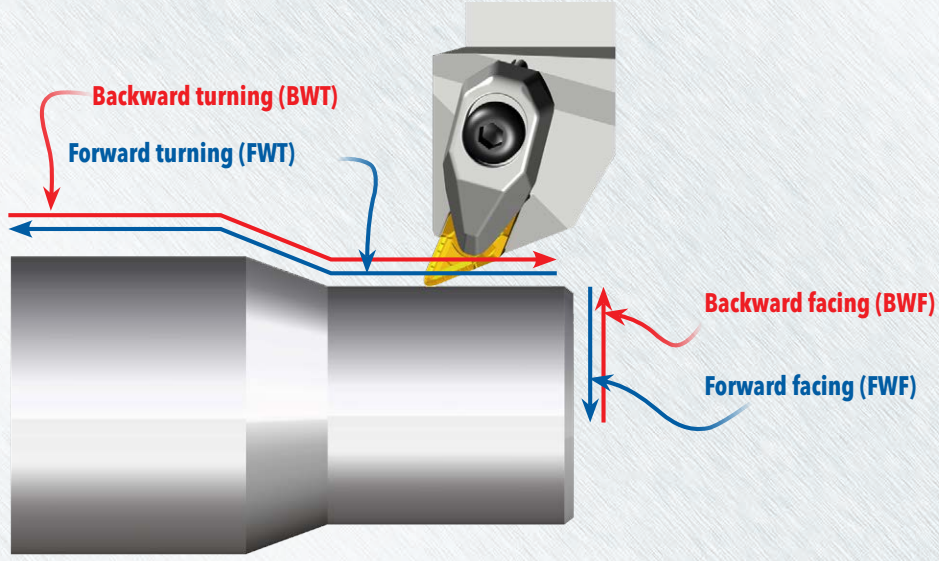

	BWT Backward Turning	BWF Backward Facing	FWT Forward Turning	FWF Forward Facing
f_{Min} (ipr)	.020	.020	.008	.008
$f_{Recom.}$ (ipr)	.028	.028	.010	.010
f_{Max} (ipr)	.040	.040	.016	.016
ap_{Min} (inch)	.020	.020	.040	.040
$ap_{Recom.}$ (inch)	.060	.040	.047	.047
ap_{Max} (inch)	.100	.047	.080	.080

• Capable of profile turning. Capable of high feed turning in BWT and BWF.

SUPERTURNZ™ -BS BACKWARD TURNING

TZQNL holder's **backward** turning (BWT) and ZNMV-BS's chip control range

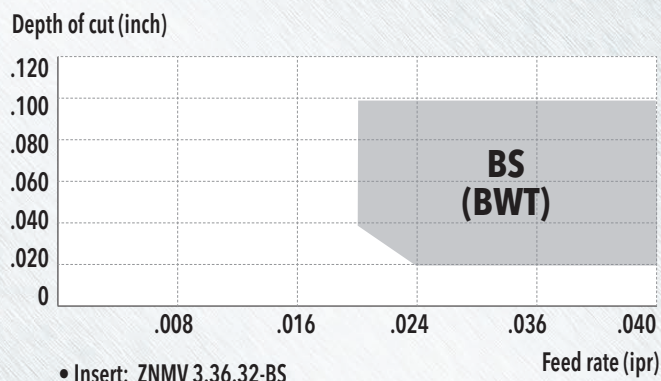
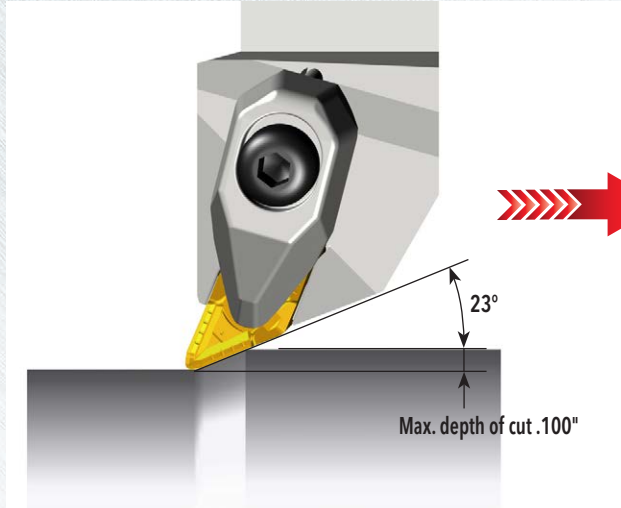

- Insert: ZNMV 3.36.32-BS
- Cutting speed (V): 100 sfm
- Material: INCONEL 718 (HB340-360)

SUPERTURNZ™ -BS FORWARD TURNING

TZQNL holder's **forward** turning (FWT) and ZNMV-BS's chip control range

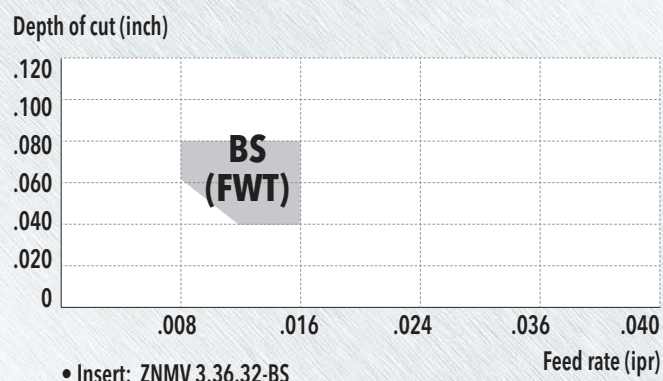
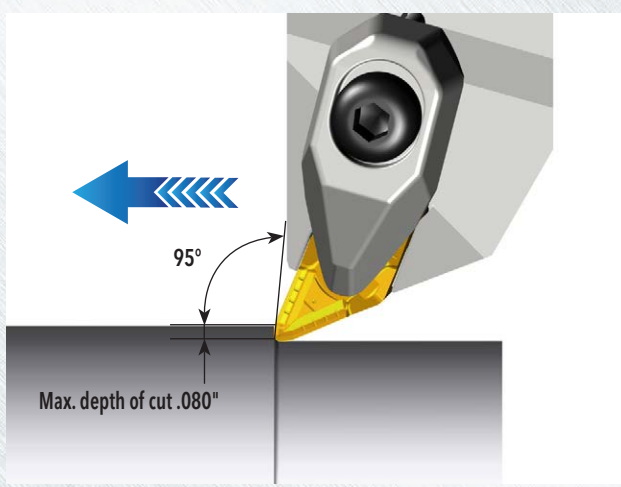

- Insert: ZNMV 3.36.32-BS
- Cutting speed (V): 100 sfm
- Material: INCONEL 718 (HB340-360)

SUPERTURNZ™ ZNMV Y-BF INSERT GEOMETRY

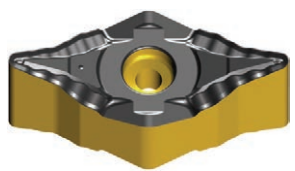
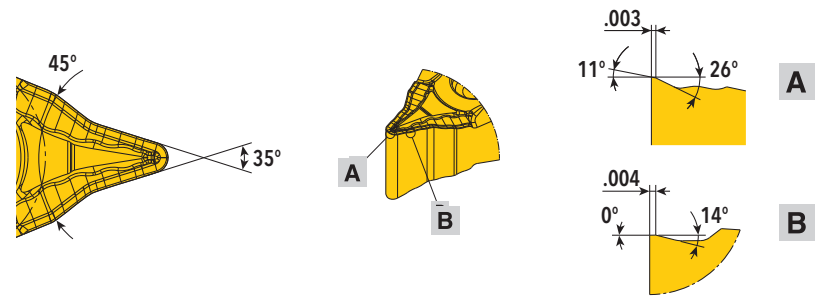
Material	Chip breaker	Cutting edge geometry
P		

SUPERTURNZ™ Y-BF APPLICATION RANGE

Application range of ZNMV Y-BF insert with TZQNL holder - Capable of all directional turning.

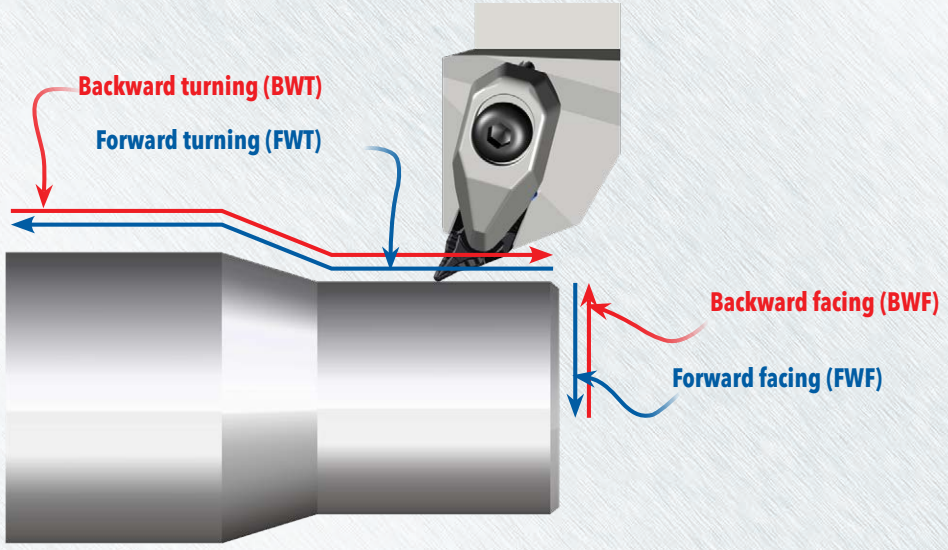

	BWT Backward Turning	BWF Backward Facing	FWT Forward Turning	FWF Forward Facing
f_{Min} (ipr)	.008	.008	.008	.008
$f_{Recom.}$ (ipr)	.016	.016	.010	.010
f_{Max} (ipr)	.020	.020	.014	.014
ap_{Min} (inch)	.010	.010	.010	.010
$ap_{Recom.}$ (inch)	.047	.040	.024	.024
ap_{Max} (inch)	.060	.047	.040	.040

• Capable of undercut and profile turning. Capable of high feed turning in BWT and BWF.

SUPERTURNZ™ Y-BF BACKWARD TURNING

TZQNL holder's **backward** turning (BWT) and ZNMV Y-BF's chip control range

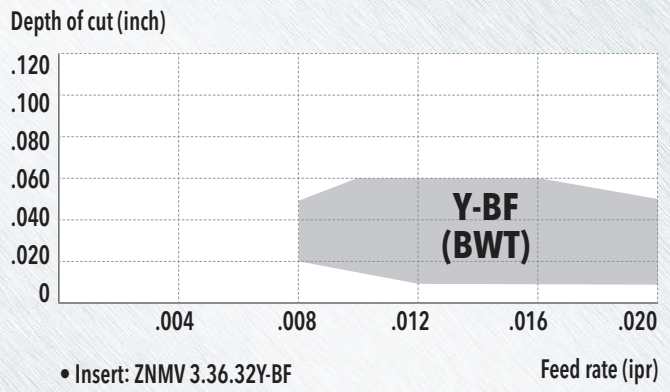
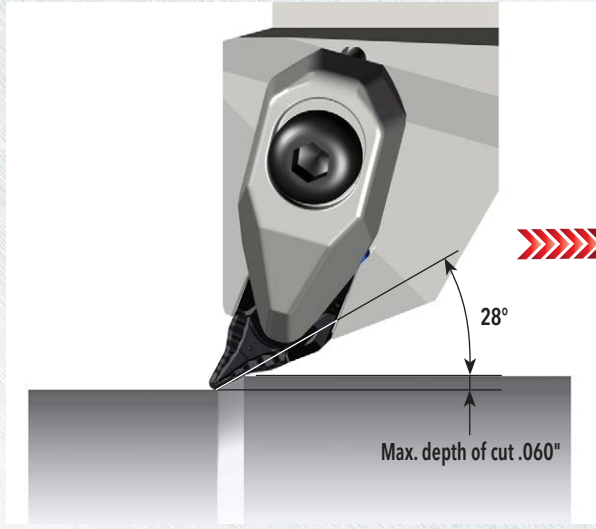

- Insert: ZNMV 3.36.32Y-BF
- Cutting speed (V): 650 sfm
- Material: AISI 4140 (HB230-260)

SUPERTURNZ™ Y-BF FORWARD TURNING

TZQNL holder's **forward** turning (FWT) and ZNMV Y-BF's chip control range

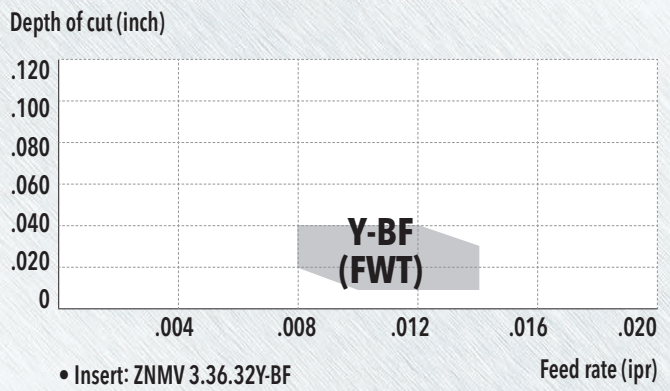
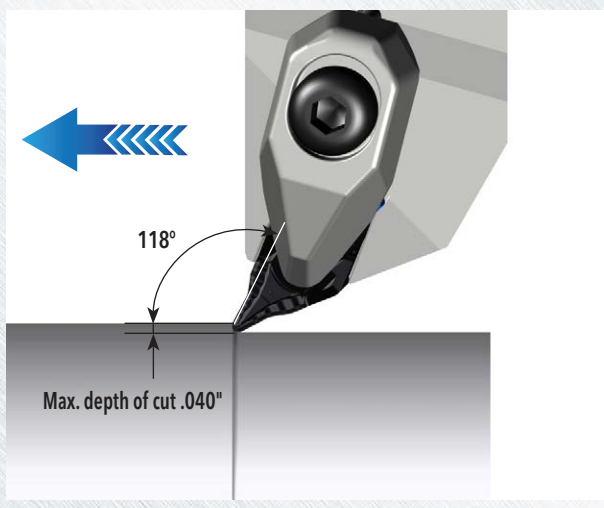

- Insert: ZNMV 3.36.32Y-BF
- Cutting speed (V): 650 sfm
- Material: AISI 4140 (HB230-260)

SUPERTURNZ™ Y-BF BI-DIRECTIONAL TURNING

TZXNN holder's left and right bi-directional turning and ZNMV Y-BF's chip control range

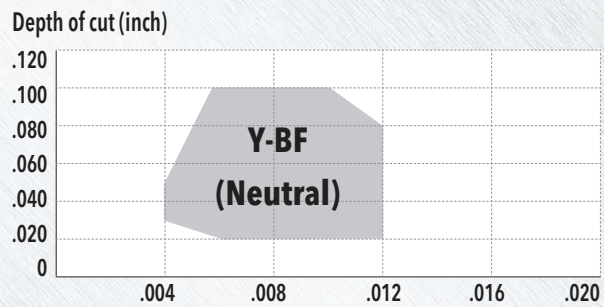
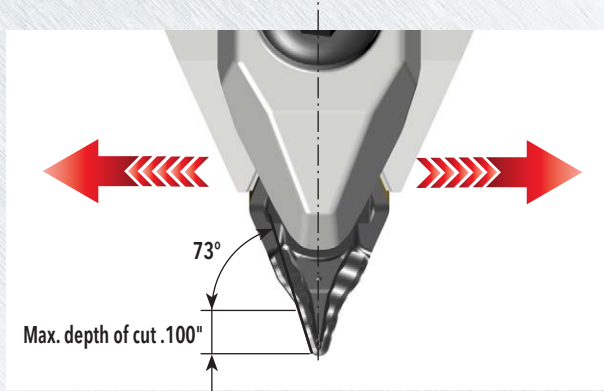

- Insert: ZNMV 3.36.32Y-BF
- Cutting speed (V): 650 sfm
- Material: AISI 4140 (HB230-260)

SUPERTURNZ™ Y-BF CHIP CONTROL COMPARISON

Insert	ZNMV 141008Y-BF (TZNN holder)	VBMT 160408 (SVVBN holder)
V=650 sfm, AISI 4140 (HB243)		

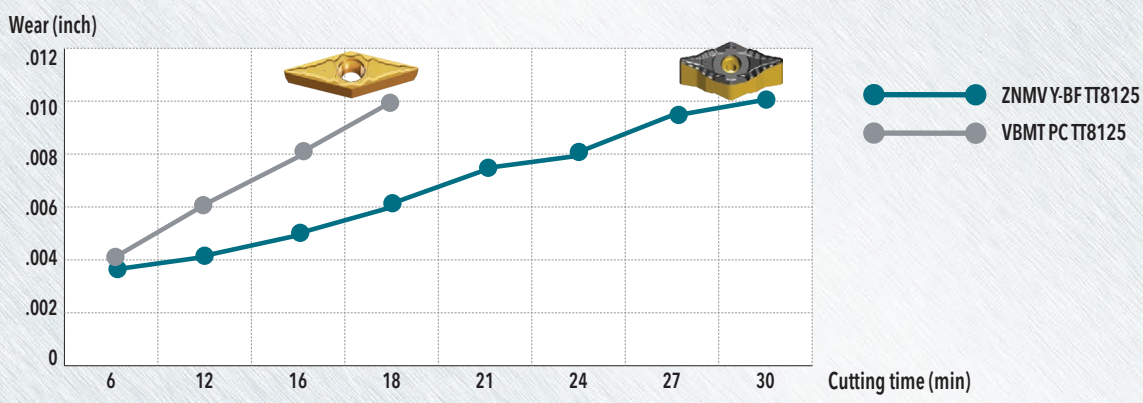

SUPERTURNZ™ Y-BF WEAR RESISTANCE COMPARISON

V=980 sfm, ap=.060", f=.008 ipr, AISI 4140 (HB245)



SUPERTURNZ™ CASE STUDY 1

High feed external backward turning

		Competitor	Ingersoll
Material		AISI 4140	
Insert		High-feed insert (CVD coated)	ZNMV 141008-BM TT8125
Cutting speed	V (sfm)	820	820
Feed rate	f (ipr)	.028	.028
Depth of cut	ap (inch)	.060	.060
Coolant		Wet	Wet
Wear after machining			

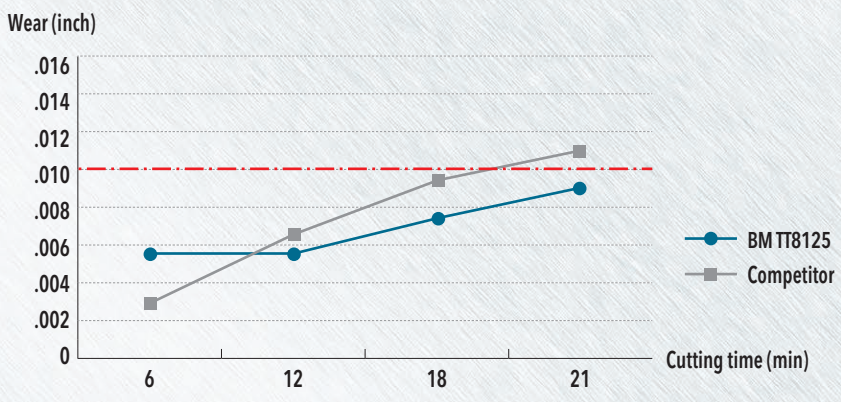



SUPERTURNZ™ SERIES TZQNR/L T-HOLDERS FOR ZNMV INSERTS

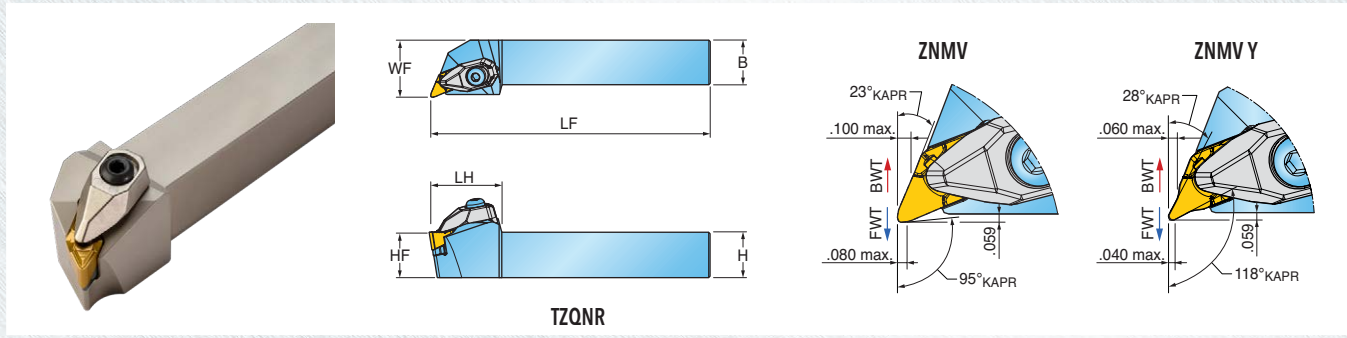

Approach Angle	Part Number	Dimension (inch)						Insert
		H Shank Height	HF Functional Height	B Shank Width	LF Functional Length	LH Head Length	WF Functional Width	
ZNMV 23°(BWT) 95°(FWT) 	TZQNR/L 16-3.3D	1.000	1.000	1.000	6.0	1.57	1.25	ZNMV 3.36.32
ZNMV Y 28°(BWT) 118°(FWT) 	TZQNR/L 20-3.3D	1.250	1.250	1.250	6.0	1.57	1.50	

BWT: Backward turning
FWT: Forward turning

Spare Parts

Part Number	Clamp	Clamp screw	Spring	Shim	Shim screw	Wrench	
TZQNR/L	DLM 3.3Z-NV	DLS 5	DSP 5	TSZ 140310	TS 35083I/HG	L-W 4	T 10

SUPERTURNZ™ SERIES TZQNR/L-TB T-HOLDERS FOR ZNMV INSERTS WITH HIGH PRESSURE COOLANT

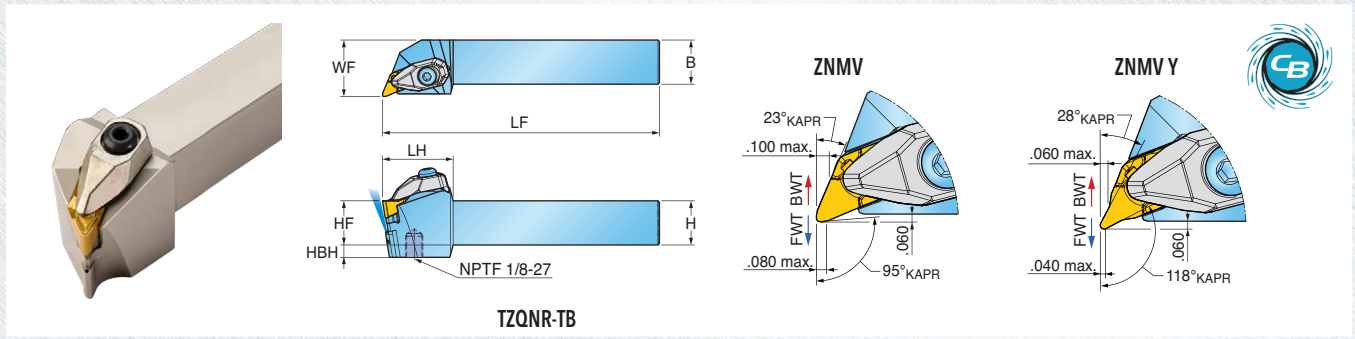

Approach Angle	Part Number	Dimension (inch)							Insert
		H Shank Height	HF Functional Height	B Shank Width	LF Functional Length	LH Head Length	WF Functional Width	HBH Head Bottom Offset Height	
<p>ZNMV 23°(BWT) 95°(FWT)</p>	TZQNR/L 16-3.3D-TB	1.000	1.000	1.000	6.0	1.57	1.25	.28	ZNMV 3.36.32
<p>ZNMV Y 28°(BWT) 118°(FWT)</p>	TZQNR/L 20-3.3D-TB	1.250	1.250	1.250	6.0	1.57	1.50	-	

BWT: Backward turning
FWT: Forward turning

Spare Parts

Part Number	Clamp	Clamp screw	Spring	Shim	Shim screw	Wrench	
TZQNR/L							
	DLM 3.3Z-NV	DLS 5	DSP 5	TSZ 140310	TS 350831/HG	L-W 4	T 10



SUPERTURNZ™ SERIES C-TZQNR/L-TB C-ADAPTERS FOR ZNMV/ZNMV Y INSERTS WITH HIGH PRESSURE COOLANT

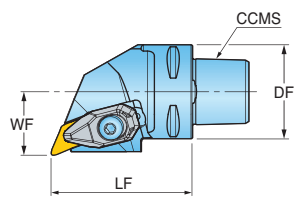

C-TZQNR-TB

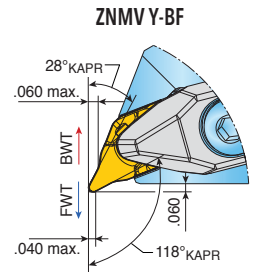
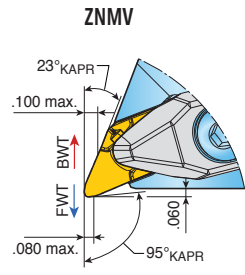

Approach Angle	Part Number	Dimension (inch)			CCMS Connection Code Machine Side	Insert
		WF Functional Width	LF Functional Length	DF Flange Dia.		
ZNMV 23°(BWT) 95°(FWT) 	C4-TZQNR/L 27060-1410-TB	27mm (1.063")	60mm (2.362")	40mm (1.575")	C4	ZNMV 3.36.32...
 ZNMV Y-BF 28°(BWT) 118°(FWT) 	C5-TZQNR/L 35060-1410-TB	35mm (1.378")	60mm (2.362")	50mm (1.968")	C5	
	C6-TZQNR/L 45065-1410-TB	45mm (1.772")	65mm (2.559")	60mm (2.362")	C6	

BWT: Backward turning
FWT: Forward turning

Spare Parts

Part Number	Clamp	Clamp screw	Spring	Shim	Shim screw	Wrench	
C-TZQNR/L-TB							
	DLM 3.3Z-NV	DLS 5	DSP 5	TSZ 140310	TS 350831/HG	L-W 4	T 10

SUPER TURN Z™ SERIES TZXNN T-HOLDERS FOR ZNMV Y INSERTS

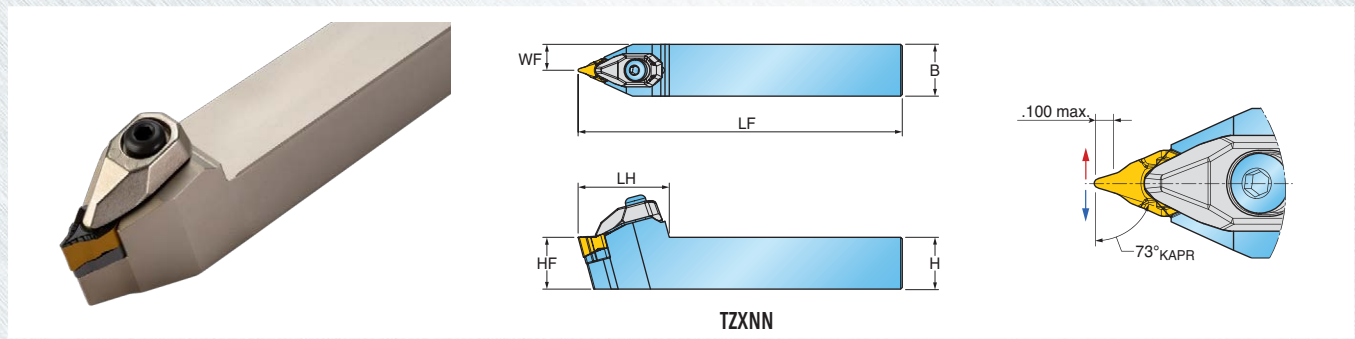

Approach Angle	Part Number	Dimension (inch)						Insert
		H Shank Height	HF Functional Height	B Shank Width	LF Functional Length	LH Head Length	WF Functional Width	
	TZXNN 16-3.3D	1.000	1.000	1.000	6.0	1.73	.500	ZNMV 3.36.32Y-BF
	TZXNN 20-3.3D	1.250	1.250	1.250	6.0	1.73	.625	

Spare Parts

Part Number	Clamp	Clamp screw	Spring	Shim	Shim screw	Wrench	
TZXNN	DLM 3.3Z-NV	DLS 5	DSP 5	TSZ 140310	TS 350831/HG	L-W 4	T 10





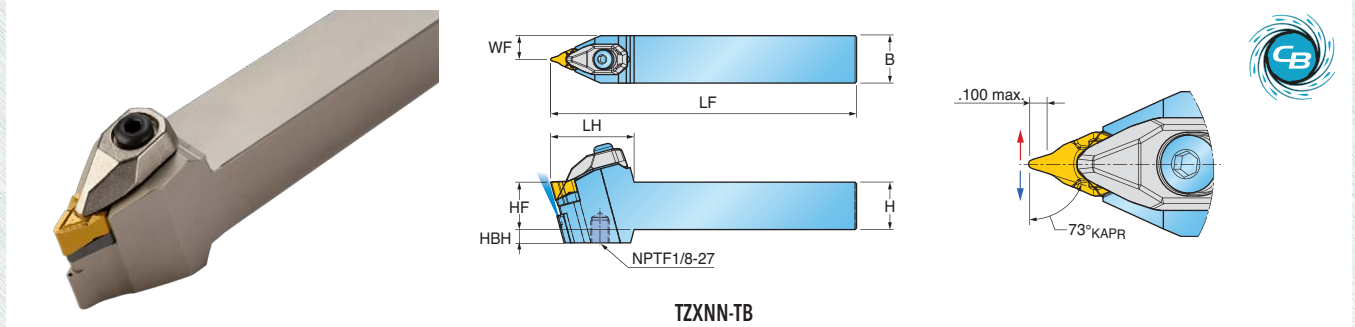

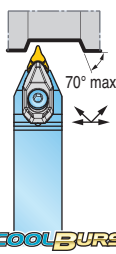

SUPERTURNZ™ SERIES TZXNN-TB T-HOLDERS FOR ZNMV Y INSERTS WITH HIGH PRESSURE COOLANT



TZXNN-TB

Approach Angle	Part Number	Dimension (inch)							Insert
		H Shank Height	HF Functional Height	B Shank Width	LF Functional Length	LH Head Length	WF Functional Width	HBH Head Bottom Offset Height	
73°  COOLBURST™	TZXNN 16-3.3D-TB	1.000	1.000	1.000	6.0	1.73	.500	.28	ZNMV 3.36.32Y-BF
	TZXNN 20-3.3D-TB	1.250	1.250	1.250	6.0	1.73	.625	-	

Spare Parts

Part Number	Clamp	Clamp screw	Spring	Shim	Shim screw	Wrench	
TZXNN-TB							
	DLM 3.3Z-NV	DLS 5	DSP 5	TSZ 140310	TS 35083I/HG	L-W 4	T 10

SUPERTURNZ™ SERIES C-TZXNN-TB C-ADAPTERS FOR ZNMV Y INSERTS WITH HIGH PRESSURE COOLANT

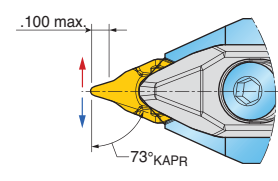
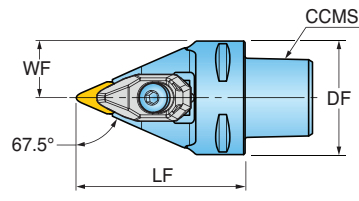

TZXNN-TB

Approach Angle	Part Number	Dimension (inch)			CCMS Connection Code Machine Side	Insert
		WF Functional Width	LF Functional Length	DF Flange Dia.		
73° COOLBURST™	C4-TZXNN00060-1410-TB	20mm (0.787")	60mm (2.362")	40mm (1.575")	C4	ZNMV 3.36.32Y-BF

Spare Parts

Part Number	Clamp	Clamp screw	Spring	Shim	Shim screw	Wrench	
C-TZXNN-TB							
	DLM 3.3Z-NV	DLS 5	DSP 5	TSZ 140310	TS 350831/HG	L-W 4	T 10



SUPERTURNZ™ SERIES ZNMV NEGATIVE RHOMBIC INSERTS WITH 80° CORNER ANGLE



BM



BS

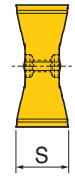
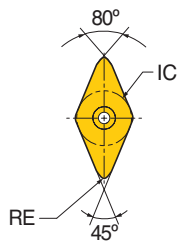

Size	Dimensions (inch)		
	IC Insert Size	S Thickness	RE Corner Radius
3.36.3	.413	.394	.031

Part Number	Backward Turning		Forward Turning		CVD Coated			PVD Coated	
	ap (inch)	Feed (ipr)	ap (inch)	Feed (ipr)	TT8105B	TT8115B	TT8125B	TT3010	TT3020
ZNMV 3.36.32-BM	.020-.100	.016-.040	.020-.080	.008-.024	•	•	•		
ZNMV 3.36.32-BS	.020-.100	.020-.040	.040-.080	.008-.016	•	•	•	•	•

Refer to New Product Announcement for more detailed application guidelines.

•: Standard items

SUPERTURNZ™ SERIES ZNMV Y NEGATIVE RHOMBIC INSERTS WITH 35° CORNER ANGLE

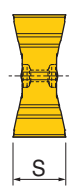
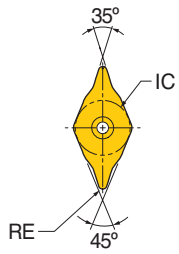

Size	Dimensions (inch)		
	IC Insert Size	S Thickness	RE Corner Radius
3.36.3	.413	.394	.031

Part Number	Backward Turning		Forward Turning		CVD Coated		
	ap (inch)	Feed (ipr)	ap (inch)	Feed (ipr)	TT8105B	TT8115B	TT8125B
ZNMV 3.36.32Y-BF	.010-.060	.008-.020	.010-.040	.008-.014	•	•	•

Refer to New Product Announcement for more detailed application guidelines.

•: Standard items