

Insert Widths:
.063" (1.6mm)
.079" (2mm)
.118" (3mm)

Chip Breakers:
SFC-Frontal land geometry suitable for higher feed rates
SFJ-Sharp cutting edge for gummy materials

Cutting Diameter Maximum:
Triangle Blades:
Up to 4.72" (120mm)
Blades: Up to 3.94" (100mm)
Square Shanks:
Up to 2.36" (60mm)

Grades:
TT9080 - PVD coated for general purpose in variety of materials
TT8020 - PVD coated with very tough substrate for difficult applications

Holders:
32mm blades
.750" and 1.00" square shank
New triangular-shaped blades

Single-Ended Rigid Inserts and Holders for Parting and Deep Grooving with Unique Adapters!

Ingersoll's CUT-SFEED line is designed with a thicker height insert and includes a specialized 3-point contact area with the bottom support blade, making it much more robust and stable than conventional deep parting and grooving systems. This insert mounting design improves position accuracy and repeatability, resulting in improved surface finish and longer tool life even under difficult machining conditions.

Features & Benefits:

- Rigid clamping of the specialized 3-point contact area for excellent accuracy, repeatability and durability
- Insert's increased height enhances strength and prolongs tool life
- User-friendly insert clamping system
- High rigidity triangular blades and dedicated holders
 - Improved productivity due to high feed machining capability
 - Stable tool life and impressive cutting performance
- Blades for T-Clamp Ultra+ inserts are also available.
- System is capable of parting off up to 4.72" (120mm) work piece diameter
- Available with **COOLEBURST** internal coolant supply for longer tool life and improved chip evacuation



CUTSPEED™

For parting or deep grooving applications, single-ended inserts are generally used but are susceptible to vibrations due to structural weakness of the clamping system as well as unstable tool life and frequent breakage stemming from bad chip evacuation.

The CUT-SPEED design uses a thicker insert featuring a special 3-point contact area with the bottom support blade, making it much more robust and stable than conventional deep parting and grooving systems. This insert clamping design improves surface roughness, ensures insert position repeatability and extends tool life even under tough machining conditions.

The holders are available in three styles:

- Square shank type (SFER/L)
- Blade type (SFGB)
- Reinforced triangular blade type (SFTB) with three insert pockets.

In particular, the triangular blade type (SFTB) and dedicated holder (THTBR/L-TB) provide superior rigidity and minimized vibrations even in high feed conditions, producing an excellent surface finish on the work piece.

 **COOLBURST** high pressure coolant is available as a standard option for the square shank and traditional blade type holders.

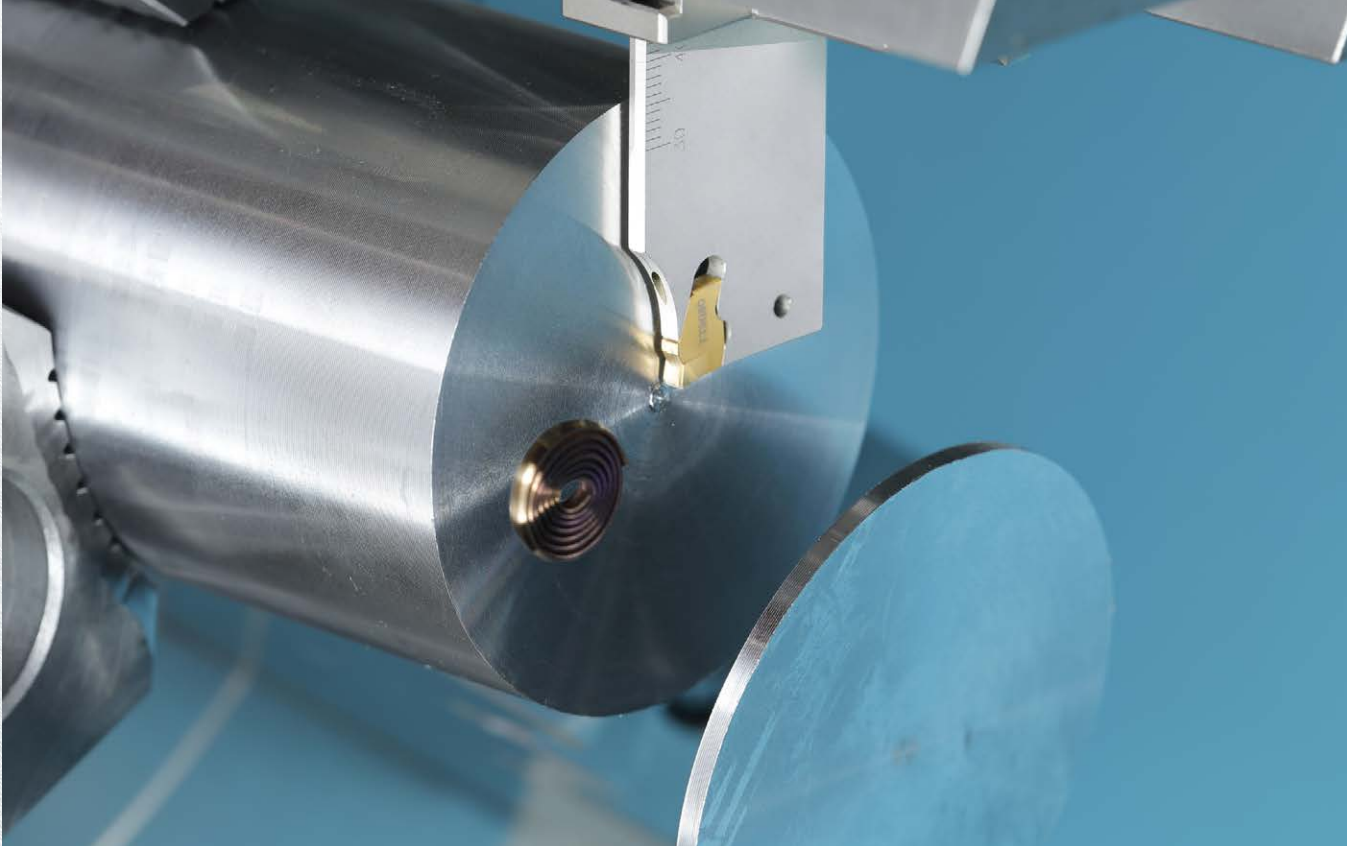

CUTSPEED™ FEATURES

Robust clamping structure and a rigid insert design

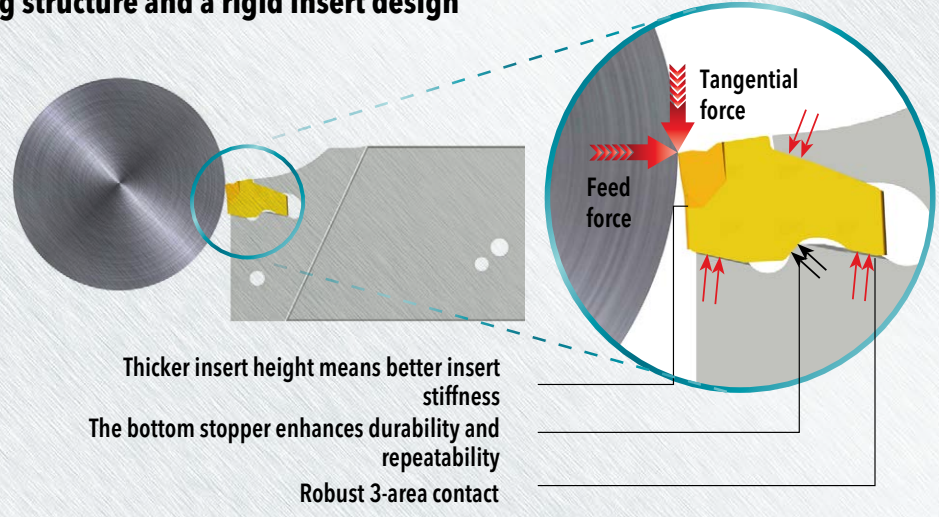

Convenient insert clamping method

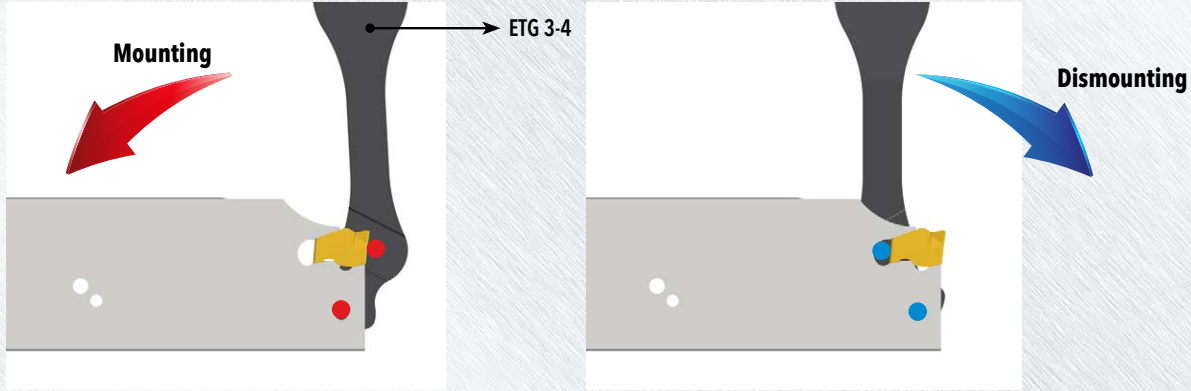

Upper and lower dual high pressure coolant channels

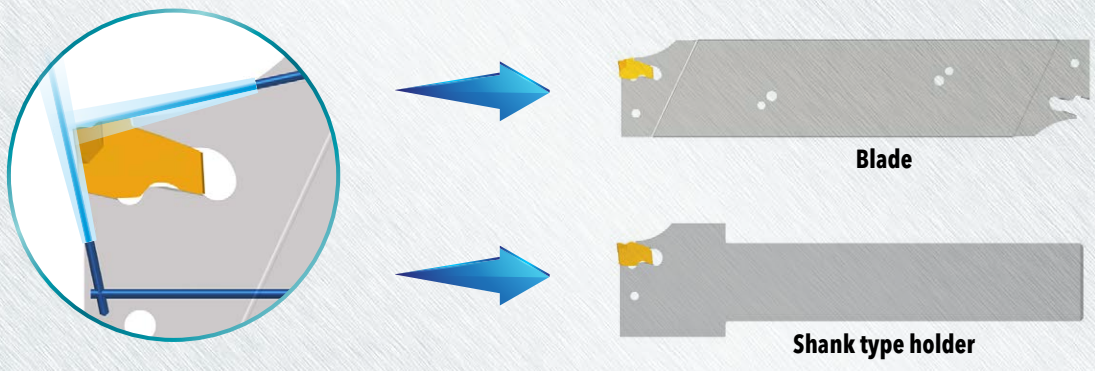



CUTSPEED™ INSERT CHIP CONTROL BY FEED RATE

		Ingersoll
Workpiece material		AISI 1045
Operation		Grooving
Insert		SFC 1.6 TT9080 (Width 1.6mm)
Cutting speed	V (sfm)	460
Feed rate	f (ipr)	.002", .003", .004", .005", .006", .008"
Depth of cut	ap (inch)	.400"
Coolant		wet

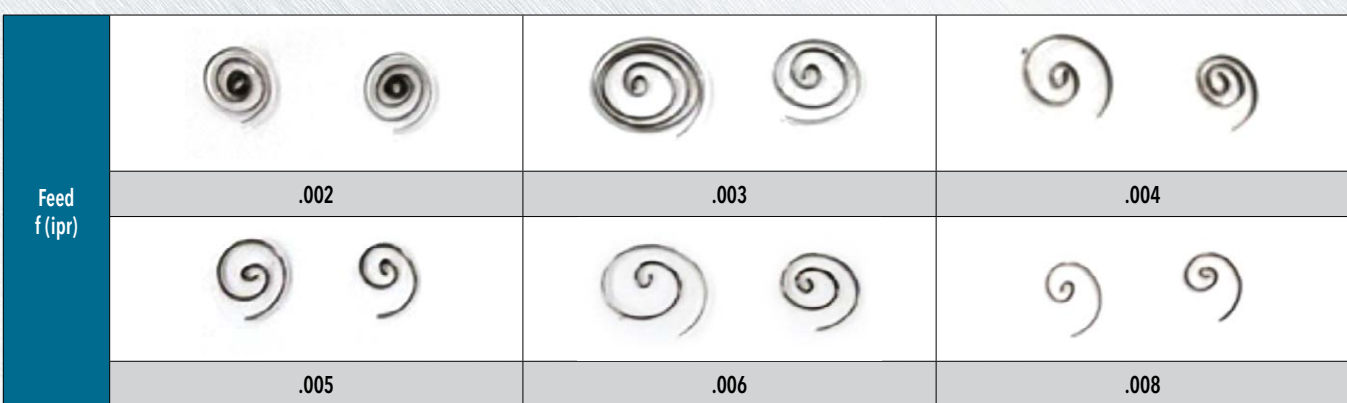

•Excellent chip control in high feed rate conditions

CUTSPEED™ CASE STUDY - CONVENTIONAL BLADE VS. CUTSPEED

		Competitor	Ingersoll
Material		AISI 304	
Operation		Parting	
Insert		Single-ended insert (Width 3mm)	SFC 3 TT9080 (Width 3mm)
Holder		Blade	SFGB 32-3
Cutting speed	V (sfm)	490	490
Feed rate	f (ipr)	.006	.006
Depth of cut	ap (inch)	.98	.98
Coolant		Wet	Wet
Tool life (pcs/corner)		80	140

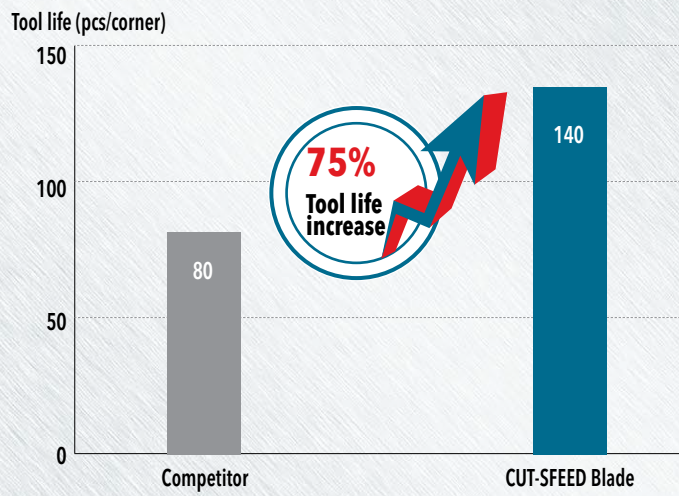



CUTSPEED™ SERIES SFGB

BLADES FOR PARTING AND DEEP GROOVING

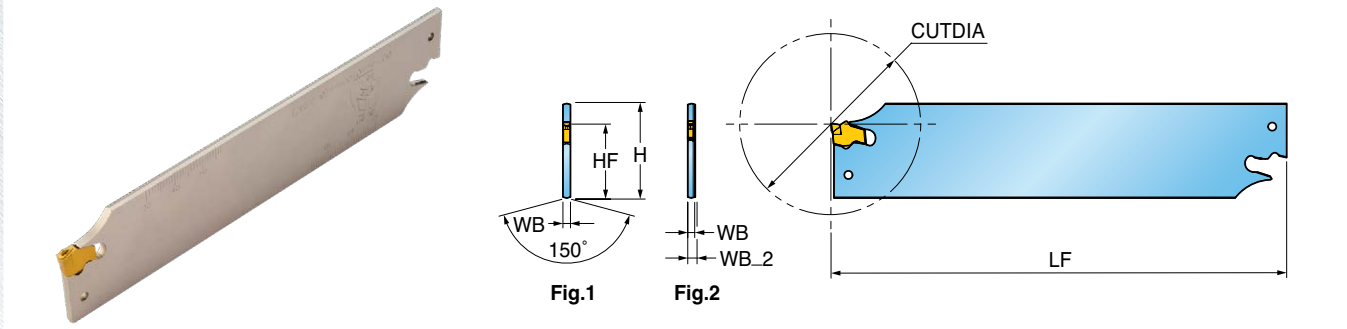

Part Number	Insert Seat Size	Dimension (inch)						Fig.	Block	Insert
		H Shank Height	HF Functional Height	LF Functional Length	WB Body Width	WB_2 Body Width	CUTDIA Cutting Diameter			
SFGB 32-1.6	1*	1.26	.97	5.9	.051	.098	1.496	2	TTBU	SFC SFJ
SFGB 32-2	2	1.26	.97	5.9	.071	.098	1.968	2		
SFGB 32-3	3	1.26	.97	5.9	.098	-	3.937	1		

*: SFC 1.6 insert only

Spare Parts

Part Number	Extractor
SFGB	ETG 3-4

Extractor sold separately.



CUTSPEED™ SERIES SFGB-TB

BLADES FOR PARTING & DEEP GROOVING WITH HIGH PRESSURE COOLANT

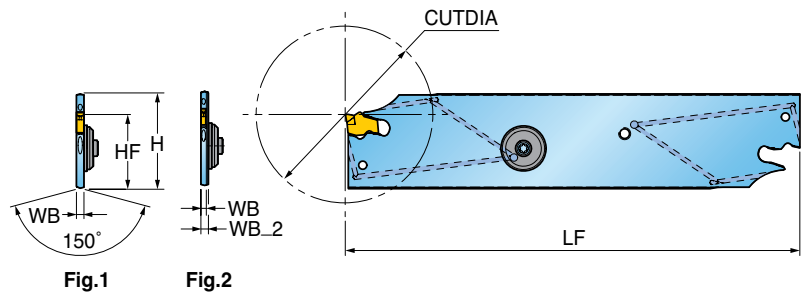

Part Number	Insert Seat Size	Dimension (inch)						CSP Coolant	Fig.	Block	Insert
		H Shank Height	HF Functional Height	LF Functional Length	WB Body Width	WB_2 Body Width	CUTDIA Cutting Diameter				
SFGB 32-2-TB	2	1.26	.97	5.9	.051	.098	1.968	Yes	2	TTBU...TB	SF_2
SFGB 32-3-TB	3	1.26	.97	5.9	.071	-	3.937	Yes	1		SF_3

Part Number	1000 psi flow rate (gpm)	1500 psi flow rate (gpm)	2000 psi flow rate (gpm)
SFGB 32-2-TB	2.6-3.2	3.2-3.7	4.0-4.5
SFGB 32-3-TB	5.0-5.5	6.0-6.6	7.1-7.6

Spare Parts

Part Number	Sealing Screw Set	Extractor
SFGB-TB	SGC 340	ETG 3-4

Extractor sold separately.



CUTSPEED™ SERIES TTBU-TB

BLOCKS FOR BLADES WITH HIGH-PRESSURE COOLANT

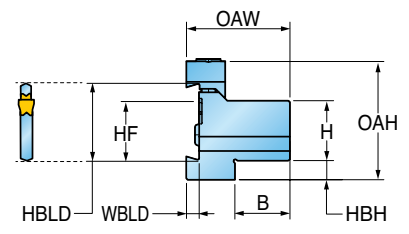
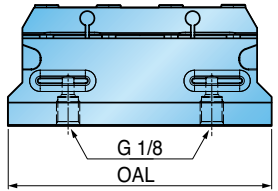
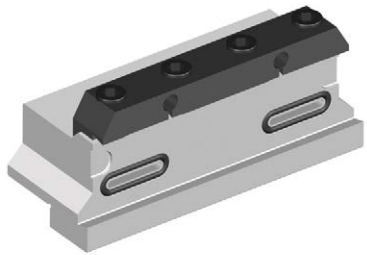

Part Number	Dimension (inch)									CSP Coolant
	H Shank Height	HF Functional Height	HBLD Blade Height	B Shank Width	HBH Head Bottom Offset Height	OAH Overall Height	WBLD Blade Width	OAL Overall Length	OAW Overall Width	
TTBU 19-32-TB	.75	.75	1.26	.75	.625	2.02	.209	3.44	1.5	Yes
TTBU 25.4-32-TB	1.00	1.00	1.26	.91	.300	1.95	.209	4.33	1.7	Yes
TTBU 31.8-32-TB	1.25	1.25	1.26	1.14	.207	2.10	.209	4.33	1.9	Yes

Spare Parts

Part Number	Screw	Clamp	O-Ring	Wrench	
TTBU 19-32-TB	SR M6X16 DIN912	BKU 100	O-RING ID14X2.5	L-W 5	
TTBU 25.4-32-TB	SR M6X16 DIN912	BKU 110	O-RING ID14X2.5	L-W 5	
TTBU 31.8-32-TB	SR M6X16 DIN912	BKU 110	O-RING ID14X2.5	L-W 5	



CUTSPEED™ SERIES SFER/L

EXTERNAL HOLDERS FOR PARTING AND DEEP GROOVING

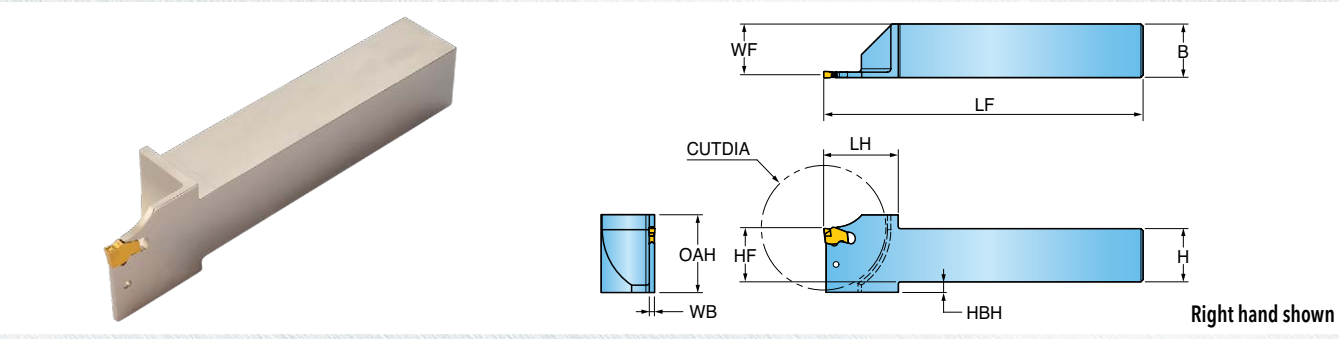

Part Number	Insert Seat Size	Dimension (inch)										Insert
		H Shank Height	HF Functional Height	B Shank Width	LF Functional Length	LH Head Length	WF Functional Width	WB Body Width	HBH Head Bottom Offset Height	CUTDIA Cutting Diameter	OAH Overall Height	
SFER/L 19-1.6T22-D45	1	.75	.75	.75	6.0	1.16	.724	.051	.14	1.77	1.14	SF_1.6
SFER/L 25.4-2T25-D50	2	1.00	1.00	1.00	6.0	1.26	.965	.071	-	1.97	1.26	SF_2
SFER/L 25.4-3T30-D60	3	1.00	1.00	1.00	6.0	1.38	.953	.094	.18	2.36	1.44	SF_3

Spare Parts

Part Number	Extractor
SFER/L	ETG 3-4 

Extractor sold separately.



CUTSPEED™ SERIES SFER/L-TB

EXTERNAL HOLDERS FOR PARTING & DEEP GROOVING WITH HIGH-PRESSURE COOLANT

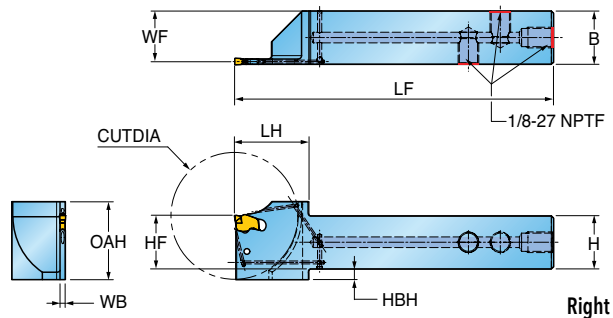

Right hand shown

Part Number	Insert Seat Size	Dimension (inch)											Insert
		H Shank Height	HF Functional Height	B Shank Width	LF Functional Length	LH Head Length	WF Functional Width	WB Body Width	HBH Head Bottom Offset Height	CUTDIA Cutting Diameter	OAH Overall Height	CSP Coolant	
SFER/L 25.4-2T25-D50-TB	2	1.00	1.00	1.00	6.0	1.26	.965	.071	-	1.97	1.26	Yes	SF_2
SFER/L 25.4-3T30-D60-TB	3	1.00	1.00	1.00	6.0	1.38	.953	.094	.18	2.36	1.44	Yes	SF_3

Part Number	1000 psi flow rate (gpm)	1500 psi flow rate (gpm)	2000 psi flow rate (gpm)
SFER/L 25.4-2T25-D50-TB	2.6-3.2	3.2-3.7	4.0-4.5
SFER/L 25.4-3T30-D60-TB	3.7-4.2	4.5-5.0	5.5-6.0

Spare Parts

Part Number	Plug	Wrench	Extractor
SFER/L-TB	NPTF1/8	L-W3/16	ETG 3-4

Extractor sold separately.



CUTSPEED™ SERIES THTBR/L-TB

HOLDERS FOR TRIANGULAR BLADE WITH HIGH-PRESSURE COOLANT

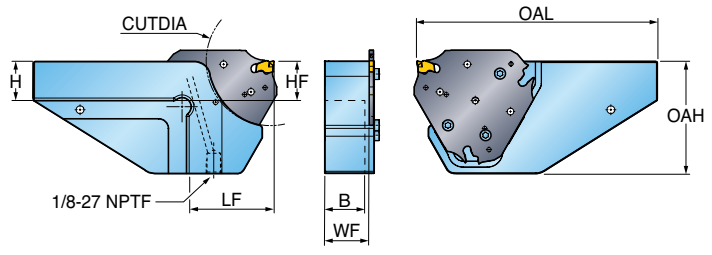

Right hand shown

Part Number	Dimension (inch)								Blade
	H Shank Height	HF Functional Height	B Shank Width	OAL Overall Length	OAH Overall Height	WF Functional Width	LF Functional Length	CUTDIA Cutting Diameter	
THTBR/L 19-D52-TB	.750	.750	.689	5.0	2.05	.925	1.57	2.05	SFTB TGTB
THTBR/L 25.4-D52-TB	1.00	1.00	.886	5.4	2.05	1.122	1.57	2.05	
THTBR/L 19-D82-TB	.750	.750	.689	5.5	2.84	.925	2.03	3.23	
THTBR/L 25.4-D82-TB	1.00	1.00	.886	6.0	2.84	1.122	2.03	3.23	SFTB
THTBR/L 25.4-D120-TB	1.00	1.00	.886	6.5	3.74	1.122	2.64	4.72	
THTBR/L 31.8-D120-TB	1.25	1.25	1.142	6.5	3.74	1.378	2.64	4.72	

Spare Parts

Part Number	Screw	Wrench
THTBR/L-TB	SH M4X0.7X10-TX	T 20



CUTSPEED™ SERIES SFTB

TRIANGULAR BLADES FOR CUT-SPEED INSERT

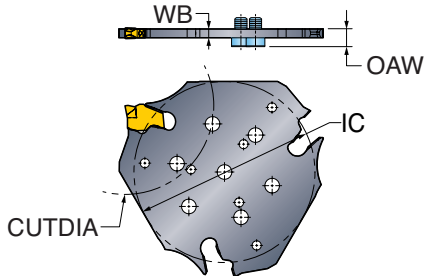

Part Number	Insert Seat Size	Dimension (inch)				Insert
		IC Diameter	WB Body Width	CUTDIA Cutting Diameter	OAW Overall Width	
SFTB D52-2	2	2.094	.071	2.05	.193	SFC SFJ
SFTB D52-3	3	2.094	.098	2.05	.220	
SFTB D82-2	2	2.531	.071	3.23	.193	
SFTB D82-3	3	2.531	.098	3.23	.220	
SFTB D120-2	2	3.364	.071	4.72	.193	
SFTB D120-3	3	3.364	.098	4.72	.220	

Spare Parts

Part Number	Extractor
SFTB	ETG 3-4

Extractor sold separately.



CUTSPEED™ SERIES SFTB-TB

TRIANGULAR BLADES FOR CUT-SPEED INSERT WITH HIGH-PRESSURE COOLANT

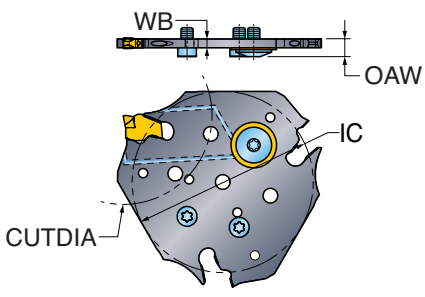

Part Number	Insert Seat Size	Dimension (inch)				Insert
		IC Diameter	WB Body Width	CUTDIA Cutting Diameter	OAW Overall Width	
SFTB D52-2-TB	2	2.094	.071	2.05	.193	SFC SFJ
SFTB D52-3-TB	3	2.094	.098	2.05	.220	
SFTB D82-2-TB	2	2.531	.071	3.23	.193	
SFTB D82-3-TB	3	2.531	.098	3.23	.220	
SFTB D120-2-TB	2	3.364	.071	4.72	.193	
SFTB D120-3-TB	3	3.364	.098	4.72	.220	

Spare Parts

Part Number	Extractor
SFTB	ETG 3-4

Extractor sold separately.



TOCLAMP^{ULTRA+} SERIES TGTB

TRIANGULAR BLADES FOR T-CLAMP INSERT

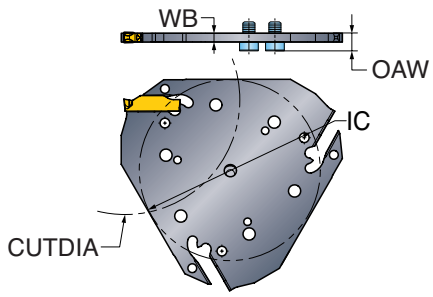
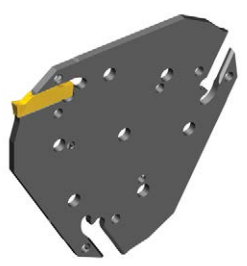

Part Number	Insert Seat Size	Dimension (inch)				Insert
		IC Diameter	WB Body Width	CUTDIA Cutting Diameter	OAW Overall Width	
TGTB D52-2	2	2.094	.071	2.05	.193	*TDC/J/T TDXU/XT TSC/J
TGTB D52-3	3	2.094	.098	2.05	.220	
TGTB D82-2	2	2.531	.071	3.23	.193	
TGTB D82-3	3	2.531	.098	3.23	.220	

Spare Parts

Part Number	Extractor
TGTB	EDG-33B 

Extractor sold separately.
* Refer to Ingersoll website for all T-ClampUltra+ insert options.



TOCLAMP^{ULTRA+} SERIES TGTB-TB

TRIANGULAR BLADES FOR T-CLAMP INSERT WITH HIGH-PRESSURE COOLANT

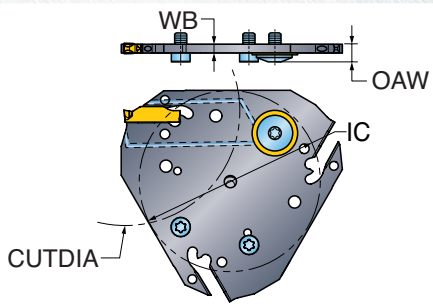
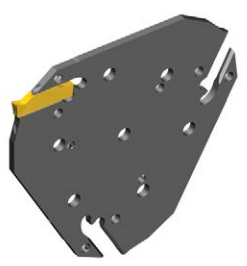

Part Number	Insert Seat Size	Dimension (inch)				Insert
		IC Diameter	WB Body Width	CUTDIA Cutting Diameter	OAW Overall Width	
TGTB D52-2-TB	2	2.094	.071	2.05	.193	*TDC/J/T TDXU/XT TSC/J
TGTB D52-3-TB	3	2.094	.098	2.05	.220	
TGTB D82-2-TB	2	2.531	.071	3.23	.193	
TGTB D82-3-TB	3	2.531	.098	3.23	.220	

Spare Parts

Part Number	Extractor
TGTB	EDG-33B 

Extractor sold separately.
* Refer to Ingersoll website for all T-ClampUltra+ insert options.



CUTSPEED™ SERIES SFC

SINGLE-ENDED INSERTS FOR PARTING & DEEP GROOVING WITH C-TYPE CHIP BREAKER

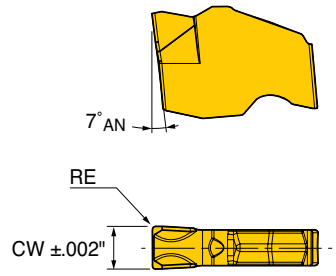

Part Number	Insert Seat Size	CW Cutting Width	RE Corner Radius	Feed (ipr)	Coated	
					TT9080	TT8020
SFC 1.6	1	.063" (1.6mm)	.008" (.2mm)	.002-.006	•	•
SFC 2	2	.079" (2mm)	.008" (.2mm)	.003-.008	•	•
SFC 3	3	.118" (3mm)	.008" (.2mm)	.004-.010	•	•

•: Standard items

CUTSPEED™ SERIES SFJ

SINGLE-ENDED INSERTS FOR PARTING & DEEP GROOVING WITH J-TYPE CHIP BREAKER

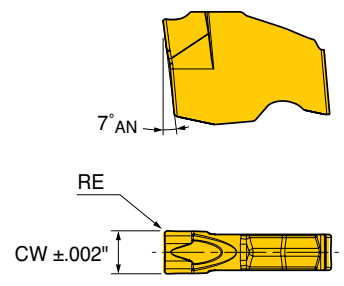

Part Number	Insert Seat Size	CW Cutting Width	RE Corner Radius	Feed (ipr)	Coated	
					TT9080	TT8020
SFJ 2	2	.079" (2mm)	.008" (.2mm)	.002-.006	•	•
SFJ 3	3	.118" (3mm)	.008" (.2mm)	.003-.008	•	•

•: Standard items

COOLBURST™ CONNECTORS

Fig.1 - STRAIGHT MALE CONNECTORS

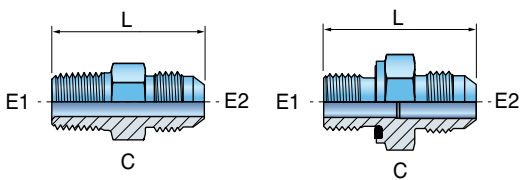
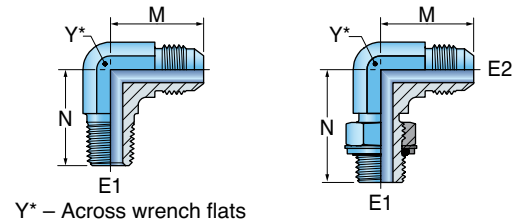

Fig. 1A

Fig. 1B

Fig.2 - ELBOW MALE CONNECTORS



Y* – Across wrench flats

Fig. 2A

Fig. 2B

Fig.	Part Number	End Size		C (hex)	L	Max Pressure (psi)
		E1	E2			
1A	TB-4-FTX-S	1/8-27 NPTF	1/4 (37° Flare)	1/2"	1.22"	6000
1B	TB-4F42EDMX-S	1/8-28 BSPP	1/4 (37° Flare)	14mm	30.2mm	7200

Fig.	Part Number	End Size		Y	M	N	Max Pressure (psi)
		E1	E2				
2A	TB-4-CTX-S	1/8-27 NPTF	1/4 (37° Flare)	7/16"	0.89"	0.78"	6000
2B	TB-4C40MX-S	1/8-28 BSPP	1/4 (37° Flare)	11mm	22.6mm	26.5mm	3600

All connectors ordered separately.

COOLBURST™ FLEXIBLE HIGH-PRESSURE HOSES

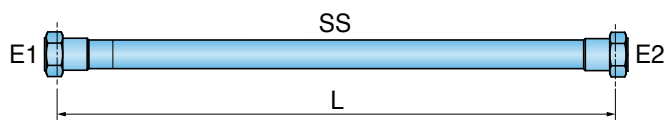

Part Number	Dimension (inch)			Max Pressure (psi)
	L	E1	E2	
TB-HOSE-7/16-7/16-8.OSS	8.0 inch	1/4 (37° Flare)	1/4 (37° Flare)	3000
TB-HOSE-7/16-7/16-10.OSS	10.0 inch	1/4 (37° Flare)	1/4 (37° Flare)	3000

All hoses ordered separately.