



HiPos+™ 09,13,17

MILLING PRODUCTS



Cutter Series:

12J1P, 2J1P: 90° Mill (.35" DOC)
12J1R, 2J1R: 90° Mill (.47" DOC)
12J1G, 2J1G: 90° Mill (.63" DOC)
22J3P, 22J3R, 22J3G: 90° Long Edge
12_1R: Chamfer End Mill
22_3R: Chamfer Long Edge Mill
12L, 2L: 70° Mill

Diameters:

.500" - 8.00" (12mm - 160mm)

Cutting Edge Angles:

15°, 30°, 45°, 60°, 70°, 75° & 90°

Insert Series:

BOMT09, BOCT09, BODT09, ZOMT09
BOMT13, BOCT13, ZOMT13
AOMT17, BOMT17, BOCT17, ZOMT17

Insert Corners:

.015", .031", .039", .047", .062",
.078", .093", .120", .125", .156",
.187" & .250" R

Materials:

Aluminum, Iron, Steel,
Stainless Steel, High-Temps,
Titanium & Hard Steel

Our Highest Positive Milling Geometry!

Designed with diversity and efficiency in mind, Ingersoll's HiPos+ Milling line features three popular insert sizes (9mm, 13mm & 17mm) that are common to several cutter body styles. Having the largest cutter diameter/length/adaption selection and the largest insert corner offering of any Ingersoll milling line, HiPos+ is an ideal multi-purpose mill that excels on low horsepower machines and long chipping materials.

Features & Benefits:

- BOMT inserts offer 2X positive rake and 2X face clearance when compared to APKT; resulting in higher efficiency, less heat and more aggressive ramping capability
- Diverse range of insert grade/geometry additions to accommodate a wide variety of materials
- Inserts with integrated wiper flats typically produce surface finishes between 32-63 Ra
- Carbide inserts equipped with 2 indexes; PCD with 1 index; Add series 12L/2L cutter to get 4 indexes
- Cutters ported with coolant to accommodate non-ferrous, stainless steel, titanium and hi-temp alloy materials

HIPOST⁺ SERIES: 12J1P (WELDON SHANK)

90° END MILL (9MM INSERT)

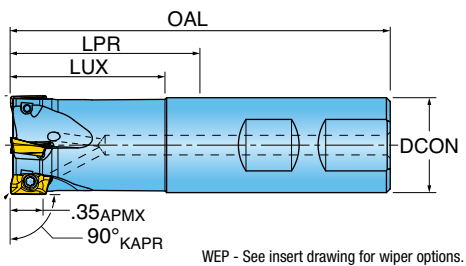

WEP - See insert drawing for wiper options.

Part Number	DC Cutting Diameter	LUX Usable Length Max.	LPR Protruding Length	OAL Overall Length	ZEFF Effective Teeth	DCON Shank Diameter	CSP Coolant	RMPX Ramp Angle Max.
12J1P-0501379R01	0.500	1.18	1.34	3.25	1	0.625	Yes	1.5
12J1P-0601379R01	0.625	1.18	1.34	3.25	2	0.625	Yes	10.0
12J1P-0701784R01	0.750	1.18	1.75	3.75	2	0.750	Yes	7.0
12J1P-0701784R02	0.750	1.18	1.75	3.75	3	0.750	Yes	7.0
12J1P-0702784R01	0.750	2.75	2.75	4.75	2	0.750	Yes	7.0
12J1P-0704084R01	0.750	2.75	4.00	6.00	2	0.750	Yes	Not Recomm.
12J1P-0801784R01	0.875	1.18	1.75	3.75	3	0.750	Yes	5.5
12J1P-1001784R01	1.000	1.75	1.75	3.75	3	0.750	Yes	4.4
12J1P-1001784R02	1.000	1.75	1.75	3.75	4	0.750	Yes	4.4
12J1P-1201584R01	1.250	1.50	1.50	3.75	5	0.750	Yes	2.8
12J1P-1501780R01	1.500	1.75	1.75	4.00	6	1.000	Yes	2.4

NOTE: Relieve cutter body when using insert corner radii larger than R.062" (see page 41).

METRIC

Part Number	DC Cutting Diameter	LUX Usable Length Max.	LPR Protruding Length	OAL Overall Length	ZEFF Effective Teeth	DCON Shank Diameter	CSP Coolant	RMPX Ramp Angle Max.
12J1P012020W3R00	12.00 mm	20.0 mm	32.0 mm	80.0 mm	1	16.00 mm	Yes	1.5
12J1P016026W3R00	16.00 mm	26.0 mm	37.0 mm	85.0 mm	2	16.00 mm	Yes	10.0
12J1P020030W4R00	20.00 mm	30.0 mm	40.0 mm	90.0 mm	3	20.00 mm	Yes	7.0
12J1P020075W4R00	20.00 mm	75.0 mm	75.0 mm	125.0 mm	2	20.00 mm	Yes	7.0
12J1P025040W5R00	25.00 mm	40.0 mm	44.0 mm	100.0 mm	4	25.00 mm	Yes	4.4
12J1P025085W5R00	25.00 mm	85.0 mm	89.0 mm	145.0 mm	3	25.00 mm	Yes	4.4
12J1P025085W5R01	25.00 mm	85.0 mm	89.0 mm	145.0 mm	4	25.00 mm	Yes	4.4

NOTE: Relieve cutter body when using insert corner radii larger than R1.6mm (see page 41).

HIPOST[™] SERIES: 12J1P (CYLINDRICAL SHANK)

90° END MILL (9MM INSERT)

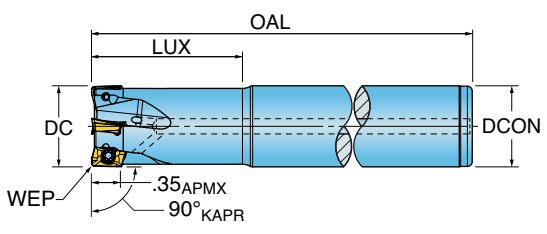

WEP - See insert drawing for wiper options.

Part Number	DC Cutting Diameter	LUX Usable Length Max.	OAL Overall Length	ZEFF Effective Teeth	DCON Shank Diameter	CSP Coolant	RMPX Ramp Angle Max.
NEW 12J1P-05030S6R10	0.500	1.79	5.00	1	0.625	Yes	1.5
NEW 12J1P-07020S7R01	0.750	1.85	7.00	3	0.750	Yes	1.5
NEW 12J1P-10020S1R01	1.000	1.85	7.00	4	1.000	Yes	1.5
NEW 12J1P-12022S9R01	1.250	2.10	8.00	5	1.250	Yes	1.5
NEW 12J1P-15025S5R01	1.500	2.30	8.50	6	1.500	Yes	1.5

NOTE: Relieve cutter body when using insert corner radii larger than R.062" (see page 41).

HIPOST[™] SERIES: 12J1P (TOPON M-ADAPTION)

90° MODULAR END MILL (9MM INSERT)

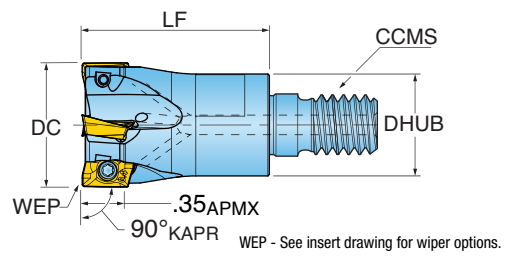

Part Number	DC Cutting Diameter	LF Functional Length	ZEFF Effective Teeth	CCMS Connection Code	DHUB Hub Diameter	CSP Coolant	RMPX Ramp Angle Max.
12J1P-06015X5R01	0.625	1.50	2	TopOn M08	0.50	Yes	10.0
12J1P-07015X6R01	0.750	1.50	3	TopOn M10	0.69	Yes	7.0
12J1P-10015X7R01	1.000	1.50	4	TopOn M12	0.81	Yes	4.4
12J1P-12017X8R01	1.250	1.75	5	TopOn M16	1.13	Yes	2.8

NOTE: Relieve cutter body when using insert corner radii larger than R.062" (see page 41).

METRIC

Part Number	DC Cutting Diameter	LF Functional Length	ZEFF Effective Teeth	CCMS Connection Code	DHUB Hub Diameter	CSP Coolant	RMPX Ramp Angle Max.
12J1P012030X4R00	12.00 mm	30.0 mm	1	TopOn M06	11.8 mm	Yes	1.5
12J1P015030X5R00	15.00 mm	30.0 mm	2	TopOn M08	13.0 mm	Yes	12.0
12J1P016035X5R00	16.00 mm	35.0 mm	2	TopOn M08	13.0 mm	Yes	10.0
12J1P020035X6R00	20.00 mm	35.0 mm	3	TopOn M10	18.0 mm	Yes	7.0
12J1P025035X7R00	25.00 mm	35.0 mm	4	TopOn M12	21.0 mm	Yes	4.4
12J1P032043X8R00	32.00 mm	43.0 mm	5	TopOn M16	29.0 mm	Yes	2.8
12J1P035043X8R00	35.00 mm	43.0 mm	5	TopOn M16	29.0 mm	Yes	2.5

NOTE: Relieve cutter body when using insert corner radii larger than R1.6mm (see page 41).

HIPOST™ SERIES: 2J1P

90° FACE MILL (9MM INSERT)

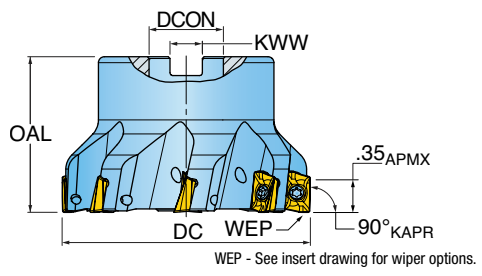

Part Number	DC Cutting Diameter	OAL Overall Length	ZEFF Effective Teeth	DCON Bore Diameter	KWW Keyway	CSP Coolant	RMPX Ramp Angle Max.
2J1P-15R01	1.500	1.57	6	0.500	0.250	Yes	2.4
2J1P-20R01	2.000	1.57	7	0.750	0.312	Yes	1.3
2J1P-25R01	2.500	1.57	8	0.750	0.312	Yes	1.0
2J1P-30R01	3.000	1.75	9	1.000	0.375	Yes	0.7

NOTE: Relieve cutter body when using insert corner radii larger than R.062" (see page 41).

METRIC

Part Number	DC Cutting Diameter	OAL Overall Length	ZEFF Effective Teeth	DCON Bore Diameter	KWW Keyway	CSP Coolant	RMPX Ramp Angle Max.
2J1P032R00	32.00 mm	32.00 mm	5	16.00 mm	8.40 mm	Yes	2.8
2J1P032R01	32.00 mm	32.00 mm	4	16.00 mm	8.40 mm	Yes	2.8
2J1P035R00	35.00 mm	32.00 mm	6	16.00 mm	8.40 mm	Yes	2.5
2J1P040R00	40.00 mm	40.00 mm	6	16.00 mm	8.40 mm	Yes	2.4
2J1P040R01	40.00 mm	40.00 mm	4	16.00 mm	8.40 mm	Yes	2.4
2J1P050R00	50.00 mm	40.00 mm	7	22.00 mm	10.40 mm	Yes	1.3
2J1P050R01	50.00 mm	40.00 mm	4	22.00 mm	10.40 mm	Yes	1.3
2J1P063R00	63.00 mm	40.00 mm	8	22.00 mm	10.40 mm	Yes	1.0
2J1P063R01	63.00 mm	40.00 mm	6	22.00 mm	10.40 mm	Yes	1.0
2J1P080R00	80.00 mm	50.00 mm	10	27.00 mm	12.40 mm	Yes	0.6
2J1P100R00	100.00 mm	50.00 mm	12	32.00 mm	14.40 mm	Yes	0.5

NOTE: Relieve cutter body when using insert corner radii larger than R1.6mm (see page 41).





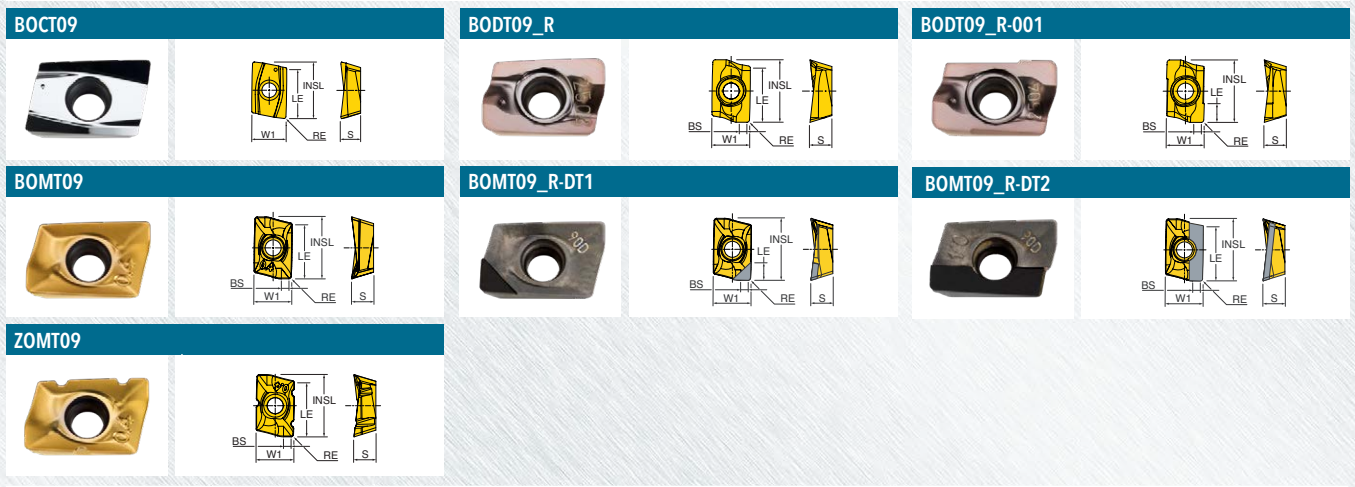
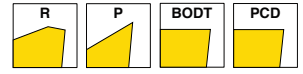



HIPOST[™] 12J1P, 2J1P INSERTS

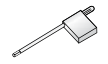

Part Number	Application	RE Corner Radius	BS Wiper Length	LE Cutting Edge Length	INSL Length	W1 Width	S Thickness	Grade	IN10K	IN2010	IN2035	IN2504	IN2505	IN2530	IN4030	IN90D
BOCT09T304FR-P	Grd/Pol for Al	0.015 R	-	0.350	0.417	0.260	0.146		•							
BOCT09T308FR-P	Grd/Pol for Al	0.031 R	-	0.350	0.414	0.260	0.144		•							
BODT09T308R	Finishing	0.031 R	0.057	0.330	0.421	0.258	0.148					•				
BODT09T308R-001	Finishing	0.031 R	0.057	0.120	0.421	0.254	0.148					•				
BOMT09T304R	Multi-Purpose	0.015 R	0.050	0.350	0.421	0.258	0.148			•			•	•	•	
BOMT09T308R	Multi-Purpose	0.031 R	0.034	0.350	0.421	0.259	0.148				•	•	•	•	•	
BOMT09T316R	Multi-Purpose	0.062 R	-	0.350	0.421	0.259	0.148				•		•	•		
BOMT09T320R	Multi-Purpose	0.078 R	-	0.350	0.421	0.259	0.148						•			
BOMT09T331R	Multi-Purpose	0.120 R	-	0.350	0.421	0.259	0.148				•		•	•		
BOMT09T304R-DT1	PCD Tipped	0.015 R	0.060	0.120	0.421	0.260	0.147									•
BOMT09T304R-DT2	PCD Tipped	0.015 R	0.060	0.370	0.421	0.260	0.147									•
ZOMT09T304R	Positive-Splitters	0.015 R	0.050	0.350	0.421	0.259	0.148				•		•	•	•	



HIPOST[™] 12J1P, 2J1P HARDWARE

								
	Insert Screw	Screw Driver	Retention Bolt	Retention Bolt w/Coolant	Wrench	**OPTIONAL**	**OPTIONAL**	**OPTIONAL**
12J1P-0501379R01	SM25-054-00	DS-T08W	-	-	-	DS-A00-.25-S	DT-11-.25	DS-T08B
12J1P-0601379R01	SM25-054-00	DS-T08W	-	-	-	DS-A00-.25-S	DT-11-.25	DS-T08B
12J1P-0701784R01	SM25-064-00	DS-T08W	-	-	-	DS-A00-.25-S	DT-11-.25	DS-T08B
12J1P-0701784R02	SM25-064-00	DS-T08W	-	-	-	DS-A00-.25-S	DT-11-.25	DS-T08B
12J1P-0702784R01	SM25-064-00	DS-T08W	-	-	-	DS-A00-.25-S	DT-11-.25	DS-T08B
12J1P-0704084R01	SM25-064-00	DS-T08W	-	-	-	DS-A00-.25-S	DT-11-.25	DS-T08B
12J1P-0801784R01	SM25-064-00	DS-T08W	-	-	-	DS-A00-.25-S	DT-11-.25	DS-T08B
12J1P-1001784R01	SM25-064-00	DS-T08W	-	-	-	DS-A00-.25-S	DT-11-.25	DS-T08B
12J1P-1001784R02	SM25-064-00	DS-T08W	-	-	-	DS-A00-.25-S	DT-11-.25	DS-T08B
12J1P-1201584R01	SM25-064-00	DS-T08W	-	-	-	DS-A00-.25-S	DT-11-.25	DS-T08B
12J1P-1501780R01	SM25-064-00	DS-T08W	-	-	-	DS-A00-.25-S	DT-11-.25	DS-T08B
12J1P-0503056R10	SM25-064-00	DS-T08W	-	-	-	DS-A00-.25-S	DT-11-.25	DS-T08B
12J1P-0702057R01	SM25-064-00	DS-T08W	-	-	-	DS-A00-.25-S	DT-11-.25	DS-T08B
12J1P-1002051R01	SM25-064-00	DS-T08W	-	-	-	DS-A00-.25-S	DT-11-.25	DS-T08B
12J1P-1202259R01	SM25-064-00	DS-T08W	-	-	-	DS-A00-.25-S	DT-11-.25	DS-T08B
12J1P-1502555R01	SM25-064-00	DS-T08W	-	-	-	DS-A00-.25-S	DT-11-.25	DS-T08B
12J1P-06015X5R01	SM25-054-00	DS-T08W	-	-	610MM	DS-A00-.25-S	DT-11-.25	DS-T08B
12J1P-07015X6R01	SM25-064-00	DS-T08W	-	-	615MM	DS-A00-.25-S	DT-11-.25	DS-T08B
12J1P-10015X7R01	SM25-064-00	DS-T08W	-	-	617MM	DS-A00-.25-S	DT-11-.25	DS-T08B
12J1P-12017X8R01	SM25-064-00	DS-T08W	-	-	622MM	DS-A00-.25-S	DT-11-.25	DS-T08B
2J1P-15R01	SM25-064-00	DS-T08W	SD-04-85	-	-	DS-A00-.25-S	DT-11-.25	DS-T08B
2J1P-20R01	SM25-064-00	DS-T08W	SD-06-46	SD-06-89	-	DS-A00-.25-S	DT-11-.25	DS-T08B
2J1P-25R01	SM25-064-00	DS-T08W	SD-06-46	SD-06-89	-	DS-A00-.25-S	DT-11-.25	DS-T08B
2J1P-30R01	SM25-064-00	DS-T08W	SD-08-48	SD-08-C9	-	DS-A00-.25-S	DT-11-.25	DS-T08B
12J1P012020W3R00	SM25-054-00	DS-T08W	-	-	-	DS-A00-.25-S	DT-11-.25	DS-T08B
12J1P016026W3R00	SM25-054-00	DS-T08W	-	-	-	DS-A00-.25-S	DT-11-.25	DS-T08B
12J1P020030W4R00	SM25-064-00	DS-T08W	-	-	-	DS-A00-.25-S	DT-11-.25	DS-T08B
12J1P020075W4R00	SM25-064-00	DS-T08W	-	-	-	DS-A00-.25-S	DT-11-.25	DS-T08B
12J1P025040W5R00	SM25-064-00	DS-T08W	-	-	-	DS-A00-.25-S	DT-11-.25	DS-T08B
12J1P025085W5R00	SM25-064-00	DS-T08W	-	-	-	DS-A00-.25-S	DT-11-.25	DS-T08B
12J1P025085W5R01	SM25-064-00	DS-T08W	-	-	-	DS-A00-.25-S	DT-11-.25	DS-T08B
12J1P012030X4R00	SM25-054-00	DS-T08W	-	-	-	DS-A00-.25-S	DT-11-.25	DS-T08B
12J1P015030X5R00	SM25-054-00	DS-T08W	-	-	610mm	DS-A00-.25-S	DT-11-.25	DS-T08B
12J1P016035X5R00	SM25-054-00	DS-T08W	-	-	610mm	DS-A00-.25-S	DT-11-.25	DS-T08B
12J1P020035X6R00	SM25-064-00	DS-T08W	-	-	615mm	DS-A00-.25-S	DT-11-.25	DS-T08B
12J1P025035X7R00	SM25-064-00	DS-T08W	-	-	617mm	DS-A00-.25-S	DT-11-.25	DS-T08B
12J1P032043X8R00	SM25-064-00	DS-T08W	-	-	622mm	DS-A00-.25-S	DT-11-.25	DS-T08B
12J1P035043X8R00	SM25-064-00	DS-T08W	-	-	622mm	DS-A00-.25-S	DT-11-.25	DS-T08B
2J1P032R00	SM25-064-00	DS-T08W	ISO4762M8X20-12.9	-	-	DS-A00-.25-S	DT-11-.25	DS-T08B
2J1P032R01	SM25-064-00	DS-T08W	ISO4762M8X20-12.9	-	-	DS-A00-.25-S	DT-11-.25	DS-T08B
2J1P035R00	SM25-064-00	DS-T08W	ISO4762M8X20-12.9	-	-	DS-A00-.25-S	DT-11-.25	DS-T08B
2J1P040R00	SM25-064-00	DS-T08W	ISO4762M8X30-12.9	-	-	DS-A00-.25-S	DT-11-.25	DS-T08B
2J1P040R01	SM25-064-00	DS-T08W	ISO4762M8X30-12.9	-	-	DS-A00-.25-S	DT-11-.25	DS-T08B
2J1P050R00	SM25-064-00	DS-T08W	ISO4762M10X25-12.9	-	-	DS-A00-.25-S	DT-11-.25	DS-T08B
2J1P050R01	SM25-064-00	DS-T08W	ISO4762M10X25-12.9	-	-	DS-A00-.25-S	DT-11-.25	DS-T08B
2J1P063R00	SM25-064-00	DS-T08W	ISO4762M10X25-12.9	-	-	DS-A00-.25-S	DT-11-.25	DS-T08B
2J1P063R01	SM25-064-00	DS-T08W	ISO4762M10X25-12.9	-	-	DS-A00-.25-S	DT-11-.25	DS-T08B
2J1P080R00	SM25-064-00	DS-T08W	ISO4762M12X35-12.9	-	-	DS-A00-.25-S	DT-11-.25	DS-T08B
2J1P100R00	SM25-064-00	DS-T08W	ISO4762M16X30-12.9	-	-	DS-A00-.25-S	DT-11-.25	DS-T08B



HIPOST[™] SERIES: 12J1R (WELDON SHANK)

90° END MILL (13MM INSERT)

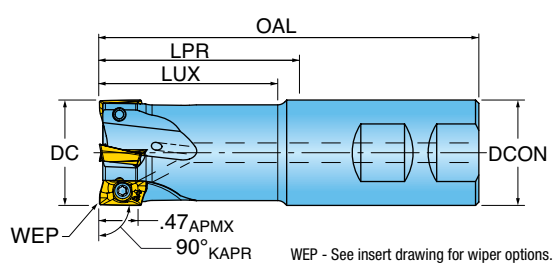

WEP - See insert drawing for wiper options.

Part Number	DC Cutting Diameter	LUX Usable Length Max.	LPR Protruding Length	OAL Overall Length	ZEFF Effective Teeth	DCON Shank Diameter	CSP Coolant	RMPX Ramp Angle Max.
12J1R-0701284R01	0.750	1.22	1.25	3.25	2	0.750	Yes	6.3
12J1R-0702084R01	0.750	1.97	2.00	4.00	1	0.750	Yes	6.3
12J1R-0703084R01	0.750	2.97	3.00	5.00	2	0.750	Yes	6.3
12J1R-1001780R01	1.000	1.72	1.75	4.00	3	1.000	Yes	7.9
12J1R-1003780R01	1.000	3.72	3.75	6.00	3	1.000	Yes	7.9
12J1R-1202281R01	1.250	2.22	2.25	4.50	4	1.250	Yes	3.1
12J1R-1204281R01	1.250	4.22	4.25	6.50	4	1.250	Yes	3.1
12J1R-1501781R01	1.500	1.72	1.75	4.00	5	1.250	Yes	2.3
12J1R-1502281R01	1.500	2.22	2.25	4.50	4	1.250	Yes	2.3
12J1R-1504281R01	1.500	4.22	4.25	6.50	4	1.250	Yes	2.3

NOTE: Relieve cutter body when using insert corner radii larger than R.078" (see page 41).

METRIC

Part Number	DC Cutting Diameter	LUX Usable Length Max.	LPR Protruding Length	OAL Overall Length	ZEFF Effective Teeth	DCON Shank Diameter	CSP Coolant	RMPX Ramp Angle Max.
12J1R020030W4R00	20.00 mm	30.0 mm	40.0 mm	90.0 mm	2	20.00 mm	Yes	7.0
12J1R025040W5R00	25.00 mm	40.0 mm	44.0 mm	100.0 mm	3	25.00 mm	Yes	7.9
12J1R025040W5R01	25.00 mm	40.0 mm	44.0 mm	100.0 mm	2	25.00 mm	Yes	7.9
12J1R032038W6R00	32.00 mm	38.0 mm	40.0 mm	100.0 mm	4	32.00 mm	Yes	5.0
12J1R032040W5R00	32.00 mm	40.0 mm	44.0 mm	100.0 mm	4	25.00 mm	Yes	5.0

NOTE: Relieve cutter body when using insert corner radii larger than R2.0mm (see page 41).



HIPOST™ SERIES: 12J1R (TOPON M-ADAPTION)

90° MODULAR END MILL (13MM INSERT)

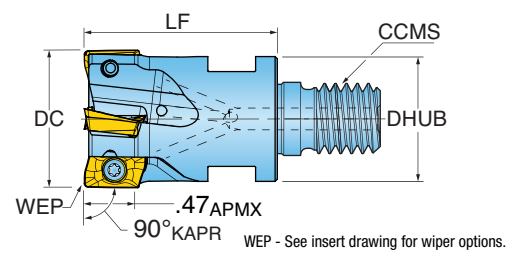

Part Number	DC Cutting Diameter	LF Functional Length	ZEFF Effective Teeth	CCMS Connection Code	DHUB Hub Diameter	CSP Coolant	RMPX Ramp Angle Max.
12J1R-07015X6R01	0.750	1.50	2	TopOn M10	0.69	Yes	6.3
12J1R-10015X7R01	1.000	1.50	3	TopOn M12	0.81	Yes	4.6
12J1R-12017X8R01	1.250	1.75	4	TopOn M16	1.13	Yes	3.1
12J1R-15017X8R01	1.500	1.75	5	TopOn M16	1.13	Yes	2.3

NOTE: Relieve cutter body when using insert corner radii larger than R.078" (see page 41).

METRIC

Part Number	DC Cutting Diameter	LF Functional Length	ZEFF Effective Teeth	CCMS Connection Code	DHUB Hub Diameter	CSP Coolant	RMPX Ramp Angle Max.
12J1R020035X6R00	20.00 mm	35.0 mm	2	TopOn M10	18.0 mm	Yes	7.0
12J1R025035X7R00	25.00 mm	35.0 mm	3	TopOn M12	21.0 mm	Yes	7.9
12J1R032043X8R00	32.00 mm	43.0 mm	4	TopOn M16	29.0 mm	Yes	5.0
12J1R035043X8R00	35.00 mm	43.0 mm	4	TopOn M16	29.0 mm	Yes	4.2
12J1R040043X8R00	40.00 mm	43.0 mm	5	TopOn M16	29.0 mm	Yes	3.2

NOTE: Relieve cutter body when using insert corner radii larger than R2.0mm (see page 41).

HIPOST[™] SERIES: 2J1R

90° FACE MILL (13MM INSERT)

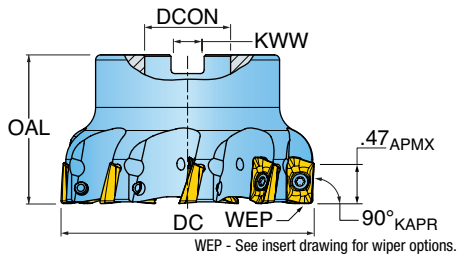

Part Number	DC Cutting Diameter	OAL Overall Length	ZEFF Effective Teeth	DCON Bore Diameter	KWW Keyway	CSP Coolant	RMPX Ramp Angle Max.
2J1R-20R01	2.000	1.57	5	0.750	0.312	Yes	1.5
2J1R-20R02	2.000	1.57	6	0.750	0.312	Yes	1.5
2J1R-25R01	2.500	1.57	6	0.750	0.312	Yes	1.1
2J1R-30R01	3.000	1.75	9	1.000	0.375	Yes	.9
2J1R-40R01	4.000	2.38	11	1.500	0.625	Yes	.6
2J1R-50R01	5.000	2.38	13	1.500	0.625	Yes	.5

NOTE: Relieve cutter body when using insert corner radii larger than R.078" (see page 41).

METRIC

Part Number	DC Cutting Diameter	OAL Overall Length	ZEFF Effective Teeth	DCON Bore Diameter	KWW Keyway	CSP Coolant	RMPX Ramp Angle Max.
2J1R035R00	35.00 mm	35.00 mm	4	16.00 mm	8.40 mm	Yes	4.2
2J1R040R00	40.00 mm	40.00 mm	5	16.00 mm	8.40 mm	Yes	3.2
2J1R040R01	40.00 mm	40.00 mm	5	22.00 mm	10.40 mm	Yes	3.2
2J1R040R02	40.00 mm	40.00 mm	4	16.00 mm	8.40 mm	Yes	3.2
2J1R040R03	40.00 mm	40.00 mm	4	22.00 mm	10.40 mm	Yes	3.2
2J1R050R00	50.00 mm	40.00 mm	6	22.00 mm	10.40 mm	Yes	2.1
2J1R050R01	50.00 mm	40.00 mm	4	22.00 mm	10.40 mm	Yes	2.1
2J1R052R00	52.00 mm	50.00 mm	5	22.00 mm	10.40 mm	Yes	2.0
2J1R063R00	63.00 mm	40.00 mm	7	22.00 mm	10.40 mm	Yes	1.4
2J1R063R01	63.00 mm	40.00 mm	6	22.00 mm	10.40 mm	Yes	1.4
2J1R066R00	66.00 mm	50.00 mm	6	27.00 mm	12.40 mm	Yes	1.2
2J1R080R00	80.00 mm	50.00 mm	9	27.00 mm	12.40 mm	Yes	1.0
2J1R080R01	80.00 mm	50.00 mm	6	27.00 mm	12.40 mm	Yes	1.0
221R100R00	100.00 mm	50.00 mm	11	32.00 mm	14.40 mm	Yes	0.8
2J1R100R01	100.00 mm	50.00 mm	8	32.00 mm	14.40 mm	Yes	0.8
2J1R125R00	125.00 mm	63.00 mm	13	40.00 mm	16.00 mm	Yes	0.6
2J1R125R01	125.00 mm	63.00 mm	10	40.00 mm	16.00 mm	Yes	0.6

NOTE: Relieve cutter body when using insert corner radii larger than R2.0mm (see page 41).



HIPOST™ 12J1R, 2J1R INSERTS

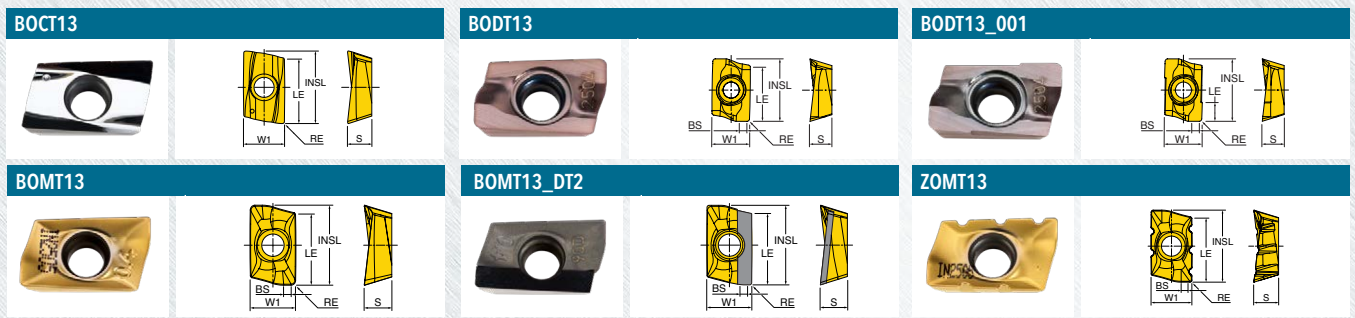
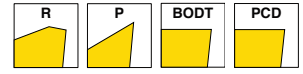

Part Number	Application	RE Corner Radius	BS Wiper Length	LE Cutting Edge Length	INSL Length	W1 Width	S Thickness	IH Insert Hand	Grade								
									IN10K	IN2005	IN2035	IN2504	IN2505	IN2530	IN4030	IN90D	
BOCT130404FR-P	Grd/Pol for Al	0.015 R	-	0.490	0.557	0.320	0.189	Right	•								
BOCT130408FR-P	Grd/Pol for Al	0.031 R	-	0.490	0.555	0.319	0.187	Right	•								
BODT130408R	Neutral; Precision	0.031 R	0.076	0.490	0.558	0.320	0.190	Right		•		•					
BODT130408R-001	Neutral; Precision	0.031 R	0.076	0.170	0.558	0.319	0.190	Right		•		•					
BOMT130404R	Multi-Purpose	0.015 R	0.067	0.490	0.558	0.320	0.190	Right			•		•	•	•		
BOMT130408R	Multi-Purpose	0.031 R	0.051	0.490	0.558	0.320	0.190	Right			•		•	•	•		
BOMT130416R	Multi-Purpose	0.062 R	0.019	0.490	0.561	0.320	0.190	Right					•	•			
BOMT130420R	Multi-Purpose	0.078 R	-	0.490	0.561	0.320	0.190	Right					•	•			
BOMT130424R	Multi-Purpose	0.093 R	-	0.490	0.560	0.320	0.190	Right					•	•			
BOMT130431R	Multi-Purpose	0.125 R	-	0.480	0.546	0.320	0.180	Right			•		•	•			
BOMT130440R	Multi-Purpose	0.156 R	-	0.480	0.538	0.320	0.183	Right					•				
BOMT130404R-DT2	PCD Tipped	0.015 R	0.055	0.490	0.557	0.320	0.190	Right									•
ZOMT130404R	Positive-Splitters	0.015 R	0.067	0.490	0.558	0.320	0.190	Right					•	•			
ZOMT130408R	Positive-Splitters	0.031 R	0.051	0.490	0.561	0.320	0.190	Right					•				



HIPOST™ 12J1R, 2J1R HARDWARE

	Insert Screw	Driver Handle	Driver Bit	Wrench	Retention Bolt	Coolant Bolt	Torque Driver Handle	Preset Torque Bit	Torque Driver Bit
12J1R-0701284R01	SM35-076-10	DS-A00T	DS-T106B	-	-	-	DS-A00-.25-T	DT-30-.25	DS-T10B1
12J1R-0702084R01	SM35-088-10	DS-A00T	DS-T106B	-	-	-	DS-A00-.25-T	DT-30-.25	DS-T10B1
12J1R-0703084R01	SM35-076-10	DS-A00T	DS-T106B	-	-	-	DS-A00-.25-T	DT-30-.25	DS-T10B1
12J1R-1001780R01	SM35-088-10	DS-A00T	DS-T106B	-	-	-	DS-A00-.25-T	DT-30-.25	DS-T10B1
12J1R-1003780R01	SM35-088-10	DS-A00T	DS-T106B	-	-	-	DS-A00-.25-T	DT-30-.25	DS-T10B1
12J1R-1202281R01	SM35-088-10	DS-A00T	DS-T106B	-	-	-	DS-A00-.25-T	DT-30-.25	DS-T10B1
12J1R-1204281R01	SM35-076-10	DS-A00T	DS-T106B	-	-	-	DS-A00-.25-T	DT-30-.25	DS-T10B1
12J1R-1501781R01	SM35-076-10	DS-A00T	DS-T106B	-	-	-	DS-A00-.25-T	DT-30-.25	DS-T10B1
12J1R-1502281R01	SM35-088-10	DS-A00T	DS-T106B	-	-	-	DS-A00-.25-T	DT-30-.25	DS-T10B1
12J1R-1504281R01	SM35-076-10	DS-A00T	DS-T106B	-	-	-	DS-A00-.25-T	DT-30-.25	DS-T10B1
12J1R-07015X6R01	SM35-076-10	DS-A00T	DS-T106B	615MM	-	-	DS-A00-.25-T	DT-30-.25	DS-T10B1
12J1R-10015X7R01	SM35-076-10	DS-A00T	DS-T106B	617MM	-	-	DS-A00-.25-T	DT-30-.25	DS-T10B1
12J1R-12017X8R01	SM35-076-10	DS-A00T	DS-T106B	622MM	-	-	DS-A00-.25-T	DT-30-.25	DS-T10B1
12J1R-15017X8R01	SM35-076-10	DS-A00T	DS-T106B	622MM	-	-	DS-A00-.25-T	DT-30-.25	DS-T10B1
2J1R-20R01	SM35-088-10	DS-A00T	DS-T106B	-	SD-06-46	SD-06-89	DS-A00-.25-T	DT-30-.25	DS-T10B1
2J1R-20R02	SM35-088-10	DS-A00T	DS-T106B	-	SD-06-46	SD-06-89	DS-A00-.25-T	DT-30-.25	DS-T10B1
2J1R-25R01	SM35-088-10	DS-A00T	DS-T106B	-	SD-06-46	SD-06-89	DS-A00-.25-T	DT-30-.25	DS-T10B1
2J1R-30R01	SM35-088-10	DS-A00T	DS-T106B	-	SD-08-46	SD-08-92	DS-A00-.25-T	DT-30-.25	DS-T10B1
2J1R-40R01	SM35-088-10	DS-A00T	DS-T106B	-	SD-12-82	SD-12-99	DS-A00-.25-T	DT-30-.25	DS-T10B1
2J1R-50R01	SM35-088-10	DS-A00T	DS-T106B	-	SD-12-82	SD-12-99	DS-A00-.25-T	DT-30-.25	DS-T10B1
12J1R020030W4R00	SM35-088-10	DS-A00T	DS-T106B	-	-	-	DS-A00-.25-T	DT-30-.25	DS-T10B1
12J1R025040W5R00	SM35-088-10	DS-A00T	DS-T106B	-	-	-	DS-A00-.25-T	DT-30-.25	DS-T10B1
12J1R025040W5R01	SM35-088-10	DS-A00T	DS-T106B	-	-	-	DS-A00-.25-T	DT-30-.25	DS-T10B1
12J1R032038W6R00	SM35-088-10	DS-A00T	DS-T106B	-	-	-	DS-A00-.25-T	DT-30-.25	DS-T10B1
12J1R032040W5R00	SM35-088-10	DS-A00T	DS-T106B	-	-	-	DS-A00-.25-T	DT-30-.25	DS-T10B1
12J1R020035X6R00	SM35-088-10	DS-A00T	DS-T106B	615mm	-	-	DS-A00-.25-T	DT-30-.25	DS-T10B1
12J1R025035X7R00	SM35-088-10	DS-A00T	DS-T106B	617mm	-	-	DS-A00-.25-T	DT-30-.25	DS-T10B1
12J1R032043X8R00	SM35-088-10	DS-A00T	DS-T106B	622mm	-	-	DS-A00-.25-T	DT-30-.25	DS-T10B1
12J1R035043X8R00	SM35-088-10	DS-A00T	DS-T106B	622mm	-	-	DS-A00-.25-T	DT-30-.25	DS-T10B1
12J1R040043X8R00	SM35-088-10	DS-A00T	DS-T106B	622mm	-	-	DS-A00-.25-T	DT-30-.25	DS-T10B1
2J1R035R00	SM35-088-10	DS-A00T	DS-T106B	-	ISO4762M8X20-12.9	-	DS-A00-.25-T	DT-30-.25	DS-T10B1
2J1R040R00	SM35-088-10	DS-A00T	DS-T106B	-	ISO4762M8X25-12.9	-	DS-A00-.25-T	DT-30-.25	DS-T10B1
2J1R040R01	SM35-088-10	DS-A00T	DS-T106B	-	ISO4762M10X25-12.9	-	DS-A00-.25-T	DT-30-.25	DS-T10B1
2J1R040R02	SM35-088-10	DS-A00T	DS-T106B	-	ISO4762M8X25-12.9	-	DS-A00-.25-T	DT-30-.25	DS-T10B1
2J1R040R03	SM35-088-10	DS-A00T	DS-T106B	-	ISO4762M10X25-12.9	-	DS-A00-.25-T	DT-30-.25	DS-T10B1
2J1R050R00	SM35-088-10	DS-A00T	DS-T106B	-	ISO4762M10X25-12.9	-	DS-A00-.25-T	DT-30-.25	DS-T10B1
2J1R050R01	SM35-088-10	DS-A00T	DS-T106B	-	ISO4762M10X25-12.9	-	DS-A00-.25-T	DT-30-.25	DS-T10B1
2J1R052R00	SM35-088-10	DS-A00T	DS-T106B	-	ISO4762M10X35-12.9	-	DS-A00-.25-T	DT-30-.25	DS-T10B1
2J1R063R00	SM35-088-10	DS-A00T	DS-T106B	-	ISO4762M10X25-12.9	-	DS-A00-.25-T	DT-30-.25	DS-T10B1
2J1R063R01	SM35-088-10	DS-A00T	DS-T106B	-	ISO4762M10X25-12.9	-	DS-A00-.25-T	DT-30-.25	DS-T10B1
2J1R066R00	SM35-088-10	DS-A00T	DS-T106B	-	ISO4762M12X35-12.9	-	DS-A00-.25-T	DT-30-.25	DS-T10B1
2J1R080R00	SM35-088-10	DS-A00T	DS-T106B	-	ISO4762M12X35-12.9	-	DS-A00-.25-T	DT-30-.25	DS-T10B1
2J1R080R01	SM35-088-10	DS-A00T	DS-T106B	-	ISO4762M12X35-12.9	-	DS-A00-.25-T	DT-30-.25	DS-T10B1
221R100R00	SM35-088-10	DS-A00T	DS-T106B	-	ISO4762M16X30-12.9	-	DS-A00-.25-T	DT-30-.25	DS-T10B1
2J1R100R01	SM35-088-10	DS-A00T	DS-T106B	-	ISO4762M16X30-12.9	-	DS-A00-.25-T	DT-30-.25	DS-T10B1
2J1R125R00	SM35-088-10	DS-A00T	DS-T106B	-	ISO4762M20X40-12.9	-	DS-A00-.25-T	DT-30-.25	DS-T10B1
2J1R125R01	SM35-088-10	DS-A00T	DS-T106B	-	ISO4762M20X40-12.9	-	DS-A00-.25-T	DT-30-.25	DS-T10B1



HIPOST[™] SERIES: 12J1G (WELDON SHANK)

90° END MILL (17MM INSERT)

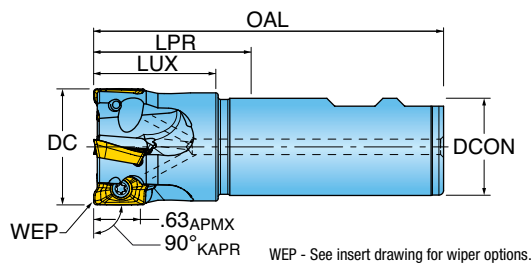

WEP - See insert drawing for wiper options.

Part Number	DC Cutting Diameter	LUX Usable Length Max.	LPR Protruding Length	OAL Overall Length	ZEFF Effective Teeth	DCON Shank Diameter	CSP Coolant	RMPX Ramp Angle Max.
12J1G-0701284R01	0.750	1.25	1.75	3.75	1	0.750	Yes	11
12J1G-1001580R01	1.000	1.50	1.75	4.00	2	1.000	No	5.8
12J1G-1001580R02	1.000	1.50	1.75	4.00	2	1.000	Yes	5.8
12J1G-1003780R01	1.000	3.50	3.75	6.00	2	1.000	Yes	5.8
12J1G-1006080R01	1.000	5.75	6.00	8.00	2	1.000	Yes	Not Recomm.
12J1G-1008080R01	1.000	7.75	8.00	10.00	2	1.000	Yes	Not Recomm.
12J1G-1201681R01	1.250	1.60	2.25	4.50	3	1.250	No	3.5
12J1G-1201681R02	1.250	1.60	2.25	4.50	3	1.250	Yes	3.5
12J1G-1204281R01	1.250	3.75	4.25	6.50	3	1.250	Yes	3.5
12J1G-1205281R01	1.250	5.25	5.75	8.00	3	1.250	Yes	Not Recomm.
12J1G-1207281R01	1.250	7.25	7.75	10.00	3	1.250	Yes	Not Recomm.
12J1G-1501681R01	1.500	2.25	2.25	4.50	4	1.250	Yes	2.3
12J1G-1501681R04	1.500	2.25	2.25	4.50	3	1.250	Yes	2.3
12J1G-1501881R01	1.500	4.25	4.25	6.50	3	1.250	Yes	2.3
12J1G-1505586R01	1.500	5.50	5.50	8.00	3	1.500	Yes	Not Recomm.
12J1G-1507586R01	1.500	7.50	7.50	10.00	3	1.500	Yes	Not Recomm.
12J1G-2001781R01	2.000	2.25	2.25	4.50	5	1.250	Yes	1.6

NOTE: Relieve cutter body when using insert corner radii larger than R.093" (see page 41).
BOMT17 produces slightly larger diameter (up to .011") for cutters 1.00" and smaller.

METRIC

Part Number	DC Cutting Diameter	LUX Usable Length Max.	LPR Protruding Length	OAL Overall Length	ZEFF Effective Teeth	DCON Shank Diameter	CSP Coolant	RMPX Ramp Angle Max.
12J1G025040W5R00	25.00 mm	40.0 mm	44.0 mm	100.0 mm	2	25.00 mm	Yes	5.0
12J1G032040W6R00	32.00 mm	36.0 mm	40.0 mm	100.0 mm	2	32.00 mm	Yes	9.0
12J1G032120W6R00	32.00 mm	120.0 mm	125.0 mm	185.0 mm	2	32.00 mm	Yes	9.0
12J1G040050W6R00	40.00 mm	50.0 mm	50.0 mm	110.0 mm	3	32.00 mm	Yes	5.0
12J1G040130W6R00	40.00 mm	130.0 mm	135.0 mm	195.0 mm	3	32.00 mm	Yes	5.0

NOTE: Relieve cutter body when using insert corner radii larger than R2.4mm (see page 41).
BOMT17 produces slightly larger diameter (up to .25mm) for 25mm cutter.

HIPOST™ SERIES: 12J1G (TOPON M-ADAPTION)

90° MODULAR END MILL (17MM INSERT)

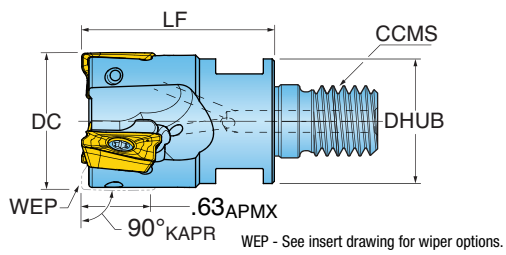

Part Number	DC Cutting Diameter	LF Functional Length	ZEFF Effective Teeth	CCMS Connection Code	DHUB Hub Diameter	CSP Coolant	RMPX Ramp Angle Max.
12J1G-10015X7R01	1.000	1.50	2	TopOn M12	0.81	Yes	5.8
12J1G-12017X8R01	1.250	1.75	3	TopOn M16	1.13	Yes	3.5
12J1G-15017X8R01	1.500	1.75	3	TopOn M16	1.13	Yes	2.3

NOTE: Relieve cutter body when using insert corner radii larger than R.093" (see page 41).
BOMT17 produces slightly larger diameter (up to .011") for cutters 1.00" and smaller.

HIPOST™ SERIES: 2J1G

90° FACE MILL (17MM INSERT)

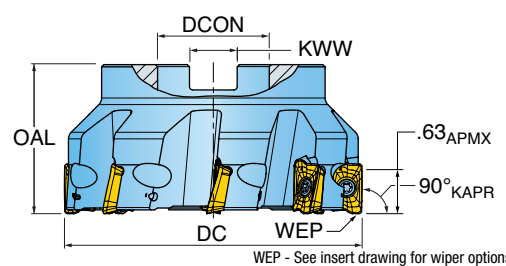

WEP - See insert drawing for wiper options.

Part Number	DC Cutting Diameter	OAL Overall Length	ZEFF Effective Teeth	DCON Bore Diameter	KWW Keyway	DBC Bolt Circle	CSP Coolant	RMPX Ramp Angle Max.
2J1G-20R01	2.000	1.57	5	0.750	0.312	NA	Yes	4.4
2J1G-20R02	2.000	1.57	3	0.750	0.312	NA	Yes	4.4
2J1G-25R01	2.500	1.57	6	0.750	0.312	NA	Yes	3.2
2J1G-30R01	3.000	1.75	7	1.000	0.375	NA	Yes	2.3
2J1G-30R02	3.000	1.75	4	1.000	0.375	NA	Yes	2.3
2J1G-40R03	4.000	2.38	8	1.500	0.625	NA	Yes	1.8
2J1G-40R04	4.000	2.38	6	1.500	0.625	NA	Yes	1.8
2J1G-50R02	5.000	2.38	9	1.500	0.625	NA	Yes	1.4
2J1G-60R01	6.000	2.00	10	2.000	0.750	NA	No	.7
2J1G-60R02	6.000	2.00	8	2.000	0.750	NA	No	.7
2J1G-80R01	8.000	2.37	12	2.500	1.000	4.00	No	.5

NOTE: Relieve cutter body when using insert corner radii larger than R.093" (see page 41).
BOMT17 produces slightly smaller diameter (up to .007") for cutters 3.00" and larger.

METRIC

Part Number	DC Cutting Diameter	OAL Overall Length	ZEFF Effective Teeth	DCON Bore Diameter	KWW Keyway	CSP Coolant	RMPX Ramp Angle Max.
2J1G040R00	40.00 mm	40.00 mm	3	16.00 mm	8.40 mm	Yes	5.0
2J1G050R00	50.00 mm	40.00 mm	4	22.00 mm	10.40 mm	Yes	4.4
2J1G050R01	50.00 mm	40.00 mm	5	22.00 mm	10.40 mm	Yes	4.4
2J1G063R00	63.00 mm	40.00 mm	5	22.00 mm	10.40 mm	Yes	3.2
2J1G063R01	63.00 mm	40.00 mm	6	22.00 mm	10.40 mm	Yes	3.2
2J1G080R00	80.00 mm	50.00 mm	6	27.00 mm	12.40 mm	Yes	2.3
2J1G080R01	80.00 mm	50.00 mm	8	27.00 mm	12.40 mm	Yes	2.3
2J1G100R00	100.00 mm	50.00 mm	6	32.00 mm	14.40 mm	Yes	1.8
2J1G100R01	100.00 mm	50.00 mm	9	32.00 mm	14.40 mm	Yes	1.8
2J1G125R00	125.00 mm	63.00 mm	7	40.00 mm	16.00 mm	No	1.4
2J1G160R00	160.00 mm	63.00 mm	8	40.00 mm	16.00 mm	No	0.7

NOTE: NOTE: Relieve cutter body when using insert corner radii larger than R2.4mm (see page 41).
BOMT17 produces slightly smaller diameter (up to .17mm) for cutters 80mm and larger.



HiPOST™ 12J1G, 2J1G INSERTS

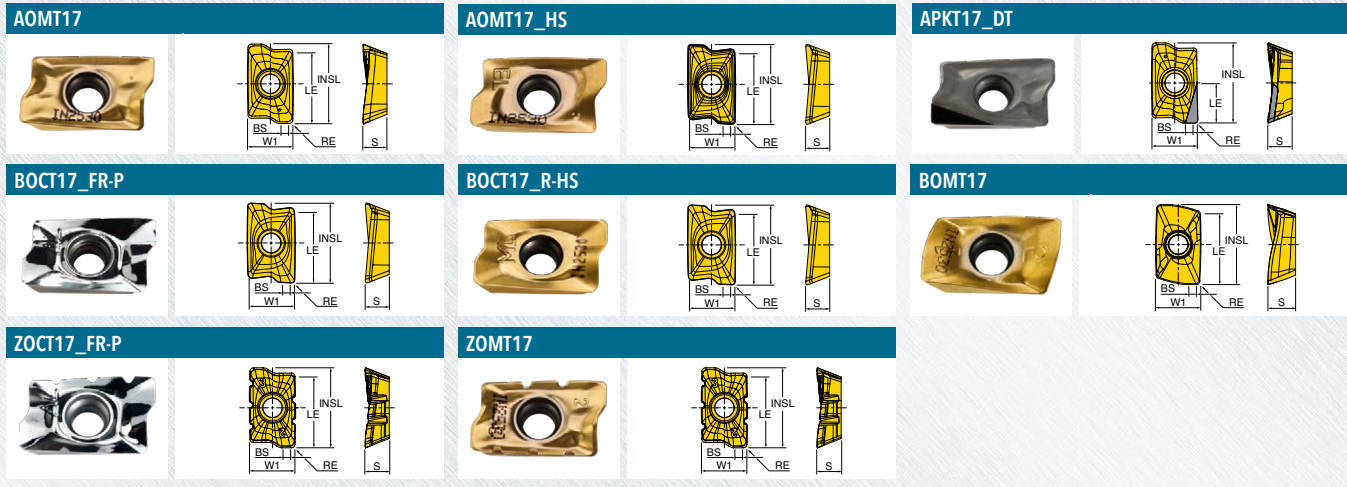
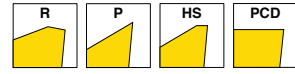

Part Number	Application	RE Corner Radius	BS Wiper Length	LE Cutting Edge Length	INSL Length	W1 Width	S Thickness	Grade	IN1030	IN10K	IN2005	IN2035	IN2504	IN2505	IN2510	IN2530	IN2540	IN4030	IN90D	IN7035	IN6537	
AOMT170504R	Multi-Purpose	0.015 R	0.100	0.633	0.728	0.421	0.218		•							•	•					
AOMT170508R	Multi-Purpose	0.031 R	0.088	0.633	0.728	0.421	0.218		•		•				•	•	•	•				•
AOMT170508R-HS	SS/Hi-Temp/Ti	0.031 R	0.082	0.633	0.728	0.421	0.218		•		•	•				•						
AOMT170510R	Multi-Purpose	0.039 R	0.078	0.633	0.728	0.421	0.218										•					
AOMT170516R	Multi-Purpose	0.062 R	0.054	0.633	0.728	0.421	0.218		•		•				•	•						
AOMT170516R-HS	SS/Hi-Temp/Ti	0.062 R	0.054	0.633	0.728	0.421	0.218									•						•
AOMT170524R	Multi-Purpose	0.093 R	0.035	0.633	0.728	0.421	0.218		•		•											
AOMT170532R	Multi-Purpose	0.125 R	0.051	0.633	0.728	0.421	0.218		•		•					•	•					
AOMT170532R-HS	SS/Hi-Temp/Ti	0.125 R	0.051	0.606	0.683	0.421	0.218									•						•
AOMT170540R	Multi-Purpose	0.156 R	-	0.633	0.728	0.421	0.218		•					•								
AOMT170548R	Multi-Purpose	0.187 R	-	0.633	0.728	0.421	0.218		•		•											
AOMT170564R	Multi-Purpose	0.250 R	-	0.633	0.728	0.421	0.218		•		•				•							
AOMT170564R-HS	SS/Hi-Temp/Ti	0.250 R	-	0.595	0.669	0.421	0.218									•						•
APKT170504R-DT	PCD Tipped	0.015 R	0.080	0.300	0.731	0.421	0.218															•
BOCT170508R-HS	Precision	0.031 R	0.082	0.633	0.728	0.421	0.218				•					•						
BOCT170508FR-P	Grd/Pol for Al	0.031 R	0.124	0.633	0.692	0.421	0.207			•												
BOCT170516FR-P	Grd/Pol for Al	0.062 R	0.080	0.630	0.726	0.427	0.217			•												
BOCT170530FR-P	Grd/Pol for Al	0.118 R	0.060	0.630	0.720	0.425	0.221			•												
BOCT170532FR-P	Grd/Pol for Al	0.125 R	0.050	0.630	0.720	0.425	0.221			•												
BOCT170564FR-P	Grd/Pol for Al	0.250 R	-	0.610	0.669	0.425	0.221			•												
BOMT170608R	Heavy Duty	0.031 R	0.086	0.630	0.744	0.421	0.256					•	•	•	•	•						
ZOCT170508FR-P	Grd/Pol for Al w/ Splitters	0.031 R	0.124	0.633	0.692	0.421	0.218			•												
ZOMT170508R	Multi-Purpose Splitters	0.031 R	0.088	0.645	0.728	0.421	0.218					•		•		•						•

HiPos+™ BOMT17 DIAMETER DEVIATION

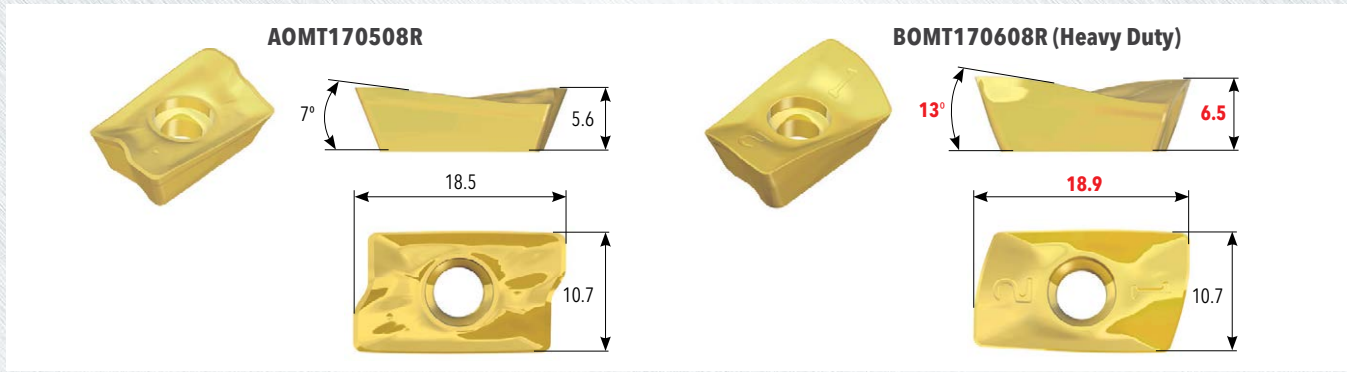

- Higher positive helix angle (AOMT17: 7°/ BOMT17: 13°) for smoother machining
- Thicker and stronger insert design (AOMT17: 5.6 mm / BOMT17: 6.5 mm)
- Compatible with the existing HiPos+ milling cutters for AOMT17

Please note possible cutter diameter deviations when using BOMT insert as follows:

Tool Diameter	Deviation of Diameter Compared to AOMT1705
.750" - 1.00"	+ .004" ~ +.011"
1.25" - 2.50"	0
3.00" - 8.00"	- .004" ~ -.007"



HIPOST™ 12J1G, 2J1G HARDWARE

	Insert Screw	Driver Handle	Driver Bit	Wrench	Retention Bolt	Coolant Bolt	Torque Driver Handle	Preset Torque Bit	Torque Driver Bit
12J1G-0701284R01	SM40-084-20	DS-A00T	DS-T156B	-	-	-	DS-A00.25-T	DT-35-.25	DS-T15B1
12J1G-1001580R01	SM40-084-20	DS-A00T	DS-T156B	-	-	-	DS-A00.25-T	DT-35-.25	DS-T15B1
12J1G-1001580R02	SM40-084-20	DS-A00T	DS-T156B	-	-	-	DS-A00.25-T	DT-35-.25	DS-T15B1
12J1G-1003780R01	SM40-084-20	DS-A00T	DS-T156B	-	-	-	DS-A00.25-T	DT-35-.25	DS-T15B1
12J1G-1006080R01	SM40-084-20	DS-A00T	DS-T156B	-	-	-	DS-A00.25-T	DT-35-.25	DS-T15B1
12J1G-1008080R01	SM40-084-20	DS-A00T	DS-T156B	-	-	-	DS-A00.25-T	DT-35-.25	DS-T15B1
12J1G-1201681R01	SM40-093-20	DS-A00T	DS-T156B	-	-	-	DS-A00.25-T	DT-35-.25	DS-T15B1
12J1G-1201681R02	SM40-093-20	DS-A00T	DS-T156B	-	-	-	DS-A00.25-T	DT-35-.25	DS-T15B1
12J1G-1204281R01	SM40-093-20	DS-A00T	DS-T156B	-	-	-	DS-A00.25-T	DT-35-.25	DS-T15B1
12J1G-1205281R01	SM40-093-20	DS-A00T	DS-T156B	-	-	-	DS-A00.25-T	DT-35-.25	DS-T15B1
12J1G-1207281R01	SM40-093-20	DS-A00T	DS-T156B	-	-	-	DS-A00.25-T	DT-35-.25	DS-T15B1
12J1G-1501681R01	SM40-093-20	DS-A00T	DS-T156B	-	-	-	DS-A00.25-T	DT-35-.25	DS-T15B1
12J1G-1501681R04	SM40-093-20	DS-A00T	DS-T156B	-	-	-	DS-A00.25-T	DT-35-.25	DS-T15B1
12J1G-1501881R01	SM40-093-20	DS-A00T	DS-T156B	-	-	-	DS-A00.25-T	DT-35-.25	DS-T15B1
12J1G-1505586R01	SM40-093-20	DS-A00T	DS-T156B	-	-	-	DS-A00.25-T	DT-35-.25	DS-T15B1
12J1G-1507586R01	SM40-093-20	DS-A00T	DS-T156B	-	-	-	DS-A00.25-T	DT-35-.25	DS-T15B1
12J1G-2001781R01	SM40-093-20	DS-A00T	DS-T156B	-	-	-	DS-A00.25-T	DT-35-.25	DS-T15B1
12J1G-10015X7R01	SM40-093-20	DS-A00T	DS-T156B	617MM	-	-	DS-A00.25-T	DT-35-.25	DS-T15B1
12J1G-12017X8R01	SM40-093-20	DS-A00T	DS-T156B	622MM	-	-	DS-A00.25-T	DT-35-.25	DS-T15B1
12J1G-15017X8R01	SM40-093-20	DS-A00T	DS-T156B	622MM	-	-	DS-A00.25-T	DT-35-.25	DS-T15B1
2J1G-20R01	SM40-120-20	DS-A00T	DS-T156B	-	SD-06-46	SD-06-89	DS-A00.25-T	DT-35-.25	DS-T15B1
2J1G-20R02	SM40-120-20	DS-A00T	DS-T156B	-	SD-06-46	SD-06-89	DS-A00.25-T	DT-35-.25	DS-T15B1
2J1G-25R01	SM40-120-20	DS-A00T	DS-T156B	-	SD-06-46	SD-06-89	DS-A00.25-T	DT-35-.25	DS-T15B1
2J1G-30R01	SM40-120-20	DS-A00T	DS-T156B	-	SD-08-47	SD08-C9	DS-A00.25-T	DT-35-.25	DS-T15B1
2J1G-30R02	SM40-120-20	DS-A00T	DS-T156B	-	SD-08-47	SD08-C9	DS-A00.25-T	DT-35-.25	DS-T15B1
2J1G-40R03	SM40-120-20	DS-A00T	DS-T156B	-	SD-12-82	SD-12-99	DS-A00.25-T	DT-35-.25	DS-T15B1
2J1G-40R04	SM40-120-20	DS-A00T	DS-T156B	-	SD-12-82	SD-12-99	DS-A00.25-T	DT-35-.25	DS-T15B1
2J1G-50R02	SM40-120-20	DS-A00T	DS-T156B	-	SD-12-82	SD-12-99	DS-A00.25-T	DT-35-.25	DS-T15B1
2J1G-60R01	SM40-120-20	DS-A00T	DS-T156B	-	-	-	DS-A00.25-T	DT-35-.25	DS-T15B1
2J1G-60R02	SM40-120-20	DS-A00T	DS-T156B	-	-	-	DS-A00.25-T	DT-35-.25	DS-T15B1
2J1G-80R01	SM40-120-20	DS-A00T	DS-T156B	-	-	-	DS-A00.25-T	DT-35-.25	DS-T15B1
12J1G025040W5R00	SM40-120-20	DS-A00T	DS-T156B	-	-	-	DS-A00.25-T	DT-35-.25	DS-T15B1
12J1G032040W6R00	SM40-120-20	DS-A00T	DS-T156B	-	-	-	DS-A00.25-T	DT-35-.25	DS-T15B1
12J1G032120W6R00	SM40-120-20	DS-A00T	DS-T156B	-	-	-	DS-A00.25-T	DT-35-.25	DS-T15B1
12J1G040050W6R00	SM40-120-20	DS-A00T	DS-T156B	-	-	-	DS-A00.25-T	DT-35-.25	DS-T15B1
12J1G040130W6R00	SM40-120-20	DS-A00T	DS-T156B	-	-	-	DS-A00.25-T	DT-35-.25	DS-T15B1
2J1G040R00	SM40-120-20	DS-A00T	DS-T156B	-	ISO4762M8X25-12.9	-	DS-A00.25-T	DT-35-.25	DS-T15B1
2J1G050R00	SM40-120-20	DS-A00T	DS-T156B	-	ISO4762M10X25-12.9	-	DS-A00.25-T	DT-35-.25	DS-T15B1
2J1G050R01	SM40-120-20	DS-A00T	DS-T156B	-	ISO4762M10X25-12.9	-	DS-A00.25-T	DT-35-.25	DS-T15B1
2J1G063R00	SM40-120-20	DS-A00T	DS-T156B	-	ISO4762M10X25-12.9	-	DS-A00.25-T	DT-35-.25	DS-T15B1
2J1G063R01	SM40-120-20	DS-A00T	DS-T156B	-	ISO4762M10X25-12.9	-	DS-A00.25-T	DT-35-.25	DS-T15B1
2J1G080R00	SM40-120-20	DS-A00T	DS-T156B	-	ISO4762M12X30-12.9	-	DS-A00.25-T	DT-35-.25	DS-T15B1
2J1G080R01	SM40-120-20	DS-A00T	DS-T156B	-	ISO4762M12X30-12.9	-	DS-A00.25-T	DT-35-.25	DS-T15B1
2J1G100R00	SM40-120-20	DS-A00T	DS-T156B	-	ISO4762M16X30-12.9	-	DS-A00.25-T	DT-35-.25	DS-T15B1
2J1G100R01	SM40-120-20	DS-A00T	DS-T156B	-	ISO4762M16X30-12.9	-	DS-A00.25-T	DT-35-.25	DS-T15B1
2J1G125R00	SM40-120-20	DS-A00T	DS-T156B	-	ISO4762M20X40-12.9	-	DS-A00.25-T	DT-35-.25	DS-T15B1
2J1G160R00	SM40-120-20	DS-A00T	DS-T156B	-	ISO4762M20X40-12.9	-	DS-A00.25-T	DT-35-.25	DS-T15B1



HIPOST™ SERIES: 22J3P (WELDON SHANK)

90° END MILL; ALL EFFECTIVE, RH HELIX (9MM INSERT)

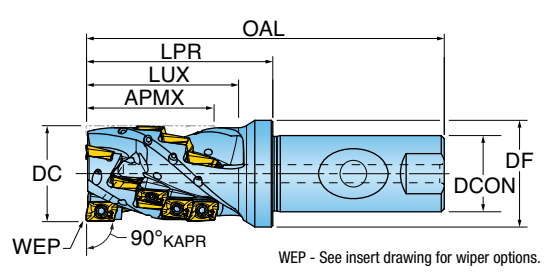

Part Number	DC Cutting Diameter	APMX Depth of Cut Max.	LUX Usable Length Max.	LPR Protruding Length	OAL Overall Length	ZNF Face Insert Count	ZNP Periphery Insert Count	NOF Flute Count	DF Flange Diameter	DCON Shank Diameter	RMPX Ramp Angle Max.
22J3P-1001780R01	1.000	1.35	1.75	1.75	4.00	2	6	2	-	1.000	4.0
22J3P-1002780R01	1.000	2.260	2.40	2.75	5.00	2	12	2	1.375	1.000	4.0
22J3P-1202480R01	1.250	1.68	2.00	2.45	4.70	3	12	3	1.400	1.000	2.5
22J3P-1502881R01	1.500	2.00	2.36	2.80	5.00	4	20	4	1.650	1.250	2.0

NOTE: Total Number of Inserts = ZNF + ZNP.
Relieve cutter body when using insert corner radii larger than R.062" (see page 41).

METRIC

Part Number	DC Cutting Diameter	APMX Depth of Cut Max.	LUX Usable Length Max.	LPR Protruding Length	OAL Overall Length	ZNF Face Insert Count	ZNP Periphery Insert Count	NOF Flute Count	DCON Shank Diameter	RMPX Ramp Angle Max.
22J3P025026W5R00	25.00 mm	25.00 mm	40.0 mm	44.0 mm	100.0 mm	2	4	2	25 mm	4.4
22J3P032034W6R00	32.00 mm	32.00 mm	50.0 mm	50.0 mm	110.0 mm	3	9	3	32 mm	2.8

NOTE: Total Number of Inserts = ZNF + ZNP.
Relieve cutter body when using insert corner radii larger than R1.6mm (see page 41).



HIPOST⁺ 22J3P INSERTS

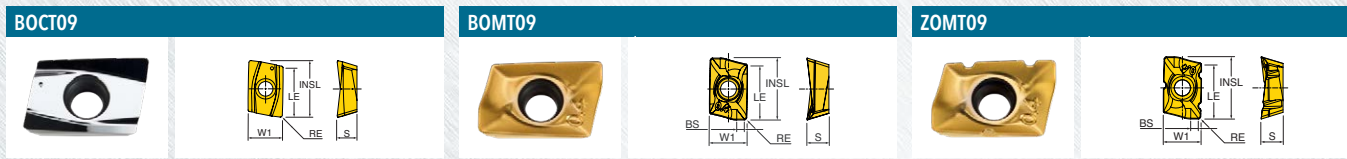

Part Number	Application	Insert Station	RE Corner Radius	BS Wiper Length	LE Cutting Edge Length	INSL Length	W1 Width	S Thickness	Grade	IN10K	IN2010	IN2035	IN2504	IN2505	IN2530	IN4030
BOCT09T304FR-P	Grd/Pol for Al	Face/Periph	0.015 R	-	0.350	0.417	0.260	0.146		•						
BOCT09T308FR-P	Grd/Pol for Al	Face/Periph	0.031 R	-	0.350	0.414	0.260	0.144		•						
BOMT09T304R	Multi-Purpose	Face/Periph	0.015 R	0.050	0.350	0.421	0.258	0.148			•		•	•	•	•
BOMT09T308R	Multi-Purpose	Face/Periph	0.031 R	0.034	0.350	0.421	0.259	0.148				•	•	•	•	•
BOMT09T316R	Multi-Purpose	Face	0.062 R	-	0.350	0.421	0.259	0.148				•		•	•	
BOMT09T331R	Multi-Purpose	Face	0.120 R	-	0.350	0.421	0.259	0.148				•		•	•	
ZOMT09T304R	Positive-Splitters	Face/Periph	0.015 R	0.050	0.350	0.421	0.259	0.148				•		•	•	•

HIPOST⁺ 22J3P HARDWARE

	Insert Screw	Screw Driver	Torque Driver Handle	Preset Torque Bit	Torque Driver Bit
22J3P-1001780R01	SM25-064-00	DS-T08W	DS-A00-.25-S	DT-11-.25	DS-T08B
22J3P-1202480R01	SM25-064-00	DS-T08W	DS-A00-.25-S	DT-11-.25	DS-T08B
22J3P-1502881R01	SM25-064-00	DS-T08W	DS-A00-.25-S	DT-11-.25	DS-T08B
22J3P025026W5R00	SM25-064-00	DS-T08W	DS-A00-.25-S	DT-11-.25	DS-T08B
22J3P032034W6R00	SM25-064-00	DS-T08W	DS-A00-.25-S	DT-11-.25	DS-T08B

HIPOST⁺ SERIES: 22J3R (WELDON SHANK)

90° END MILL, ALL EFFECTIVE, RH HELIX (13MM INSERT)

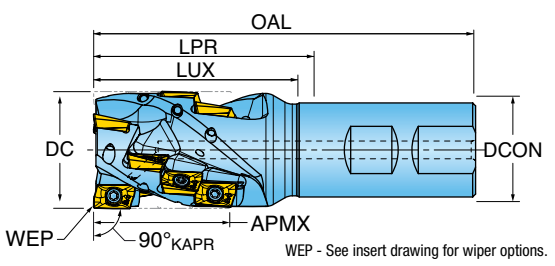

Part Number	DC Cutting Diameter	APMX Depth of Cut Max.	LUX Usable Length Max.	LPR Protruding Length	OAL Overall Length	ZNF Face Insert Count	ZNP Peripheral Insert Count	NOF Flute Count	DCON Bore Diameter	RMPX Ramp Angle Max.
22J3R032035W6R00	32.00 mm	35.00 mm	48.0 mm	48.0 mm	110.0 mm	2	4	2	32.00 mm	5.0
22J3R040046W6R00	40.00 mm	46.00 mm	65.0 mm	65.0 mm	130.0 mm	3	9	3	32.00 mm	3.2

NOTE: Total Number of Inserts = ZNF + ZNP.
Relieve cutter body when using insert corner radii larger than R2.0mm (see page 41).

HIPOST⁺ SERIES: 22J3R (SHELL MILL)

90° SHELL MILL ALL EFFECTIVE, RH HELIX (13MM INSERT)

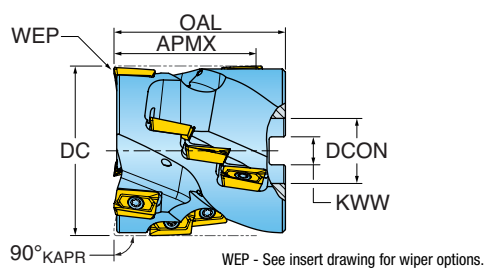

Part Number	DC Cutting Diameter	APMX Depth of Cut Max.	OAL Overall Length	ZNF Face Insert Count	ZNP Peripheral Insert Count	NOF Flute Count	DCON Bore Diameter	KWW Keyway	RMPX Ramp Angle Max.
22J3R040035F0R00	40.00 mm	35.00 mm	55.0 mm	3	6	3	16.00 mm	8.4 mm	3.2
22J3R050046F1R00	50.00 mm	46.00 mm	70.0 mm	4	12	4	22.00 mm	10.4 mm	2.1
22J3R050046F2R00	50.00 mm	46.00 mm	70.0 mm	4	12	4	27.00 mm	12.4 mm	2.1
22J3R063046F2R00	63.00 mm	46.00 mm	70.0 mm	4	12	4	27.00 mm	12.4 mm	1.4
22J3R080046F3R00	80.00 mm	46.00 mm	70.0 mm	5	15	5	32.00 mm	14.4 mm	1.0

NOTE: Total Number of Inserts = ZNF + ZNP.
Relieve cutter body when using insert corner radii larger than R2.0mm (see page 41).



HIPOST[™] SERIES 22J3R INSERTS

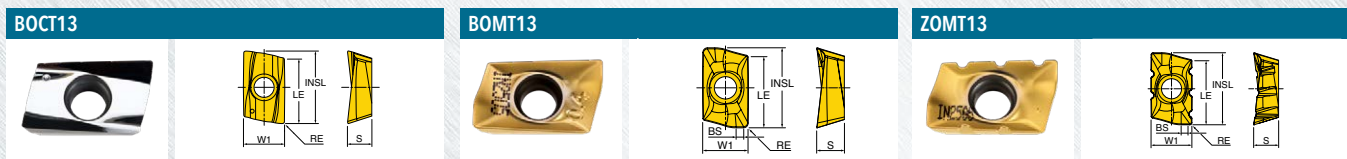
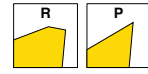

Part Number	Application	Station	RE Corner Radius	BS Wiper Length	LE Cutting Edge Length	INSL Length	W1 Width	S Thickness	IH Insert Hand	Grade	IN10K	IN2035	IN2505	IN2530	IN4030
BOCT130404FR-P	Grd/Pol for Al	Face/Periphery	0.015 R	-	0.490	0.557	0.320	0.189	Right		•				
BOCT130408FR-P	Grd/Pol for Al	Face/Periphery	0.031 R	-	0.490	0.555	0.319	0.187	Right		•				
BOMT130404R	Multi-Purpose	Face/Periphery	0.015 R	0.067	0.490	0.558	0.320	0.190	Right			•	•	•	•
BOMT130408R	Multi-Purpose	Face/Periphery	0.031 R	0.051	0.490	0.558	0.320	0.190	Right			•	•	•	•
BOMT130416R	Multi-Purpose	Face	0.062 R	0.019	0.490	0.561	0.320	0.190	Right				•	•	
BOMT130420R	Multi-Purpose	Face	0.078 R	-	0.490	0.561	0.320	0.190	Right				•	•	
BOMT130424R	Multi-Purpose	Face	0.093 R	-	0.490	0.560	0.320	0.190	Right				•	•	
BOMT130431R	Multi-Purpose	Face	0.125 R	-	0.480	0.546	0.320	0.180	Right			•	•	•	
BOMT130440R	Multi-Purpose	Face	0.156 R	-	0.480	0.538	0.320	0.183	Right				•		
ZOMT130404R	Positive-Splitters	Face/Periphery	0.015 R	0.067	0.490	0.558	0.320	0.190	Right				•	•	
ZOMT130408R	Positive-Splitters	Face/Periphery	0.031 R	0.051	0.490	0.561	0.320	0.190	Right				•		

HIPOST[™] 22J3R HARDWARE

	Insert Screw	Driver Handle	Driver Bit	Torque Driver Handle	Preset Torque Bit	Torque Driver Bit
22J3R	SM35-088-10	DS-A00T	DS-T106B	DS-A00-.25-T <small>**OPTIONAL**</small>	DT-30-.25 <small>**OPTIONAL**</small>	DS-T10B1 <small>**OPTIONAL**</small>



HIPOSTTM SERIES 22J3G (SHELL MILL)

90° ROUGH & FINISH END MILL
ALL-EFFECTIVE RH HELIX (17MM INSERT)

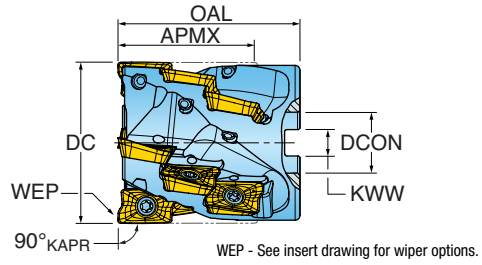

Part Number	DC Cutting Diameter	APMX Depth of Cut Max.	OAL Overall Length	ZNF Face Insert Count	ZNP Peripheral Insert Count	NOF Flute Count	DCON Bore Diameter	KWW Keyway	RMPX Ramp Angle Max.
22J3G-20022D1R02	2.000	1.71	2.25	4	8	4	0.750	0.312	4
22J3G-20041D3R02	2.000	2.80	4.17	4	20	4	1.000	0.375	4
22J3G-25030D3R02	2.500	2.27	3.00	5	15	5	1.000	0.375	3
22J3G-25040D3R02	2.500	3.35	4.00	5	25	5	1.000	0.375	3
22J3G-30040D4R02	3.000	3.35	4.00	6	30	6	1.250	0.500	2

NOTE: Total Number of Inserts = ZNF + ZNP.

METRIC

Part Number	DC Cutting Diameter	APMX Depth of Cut Max.	OAL Overall Length	ZNF Face Insert Count	ZNP Peripheral Insert Count	NOF Flute Count	DCON Bore Diameter	KWW Keyway	RMPX Ramp Angle Max.
22J3G063045F2R00	63.00 mm	45.00 mm	63.0 mm	3	6	3	27.00 mm	12.40 mm	3.2
22J3G063059F2R00	63.00 mm	59.00 mm	75.0 mm	3	9	3	27.00 mm	12.40 mm	3.2
22J3G063059F2R01	63.00 mm	59.00 mm	75.0 mm	4	12	4	27.00 mm	12.40 mm	3.2
22J3G080074F3R00	80.00 mm	74.00 mm	95.0 mm	4	16	4	32.00 mm	14.40 mm	2.3
22J3G080074F3R01	80.00 mm	74.00 mm	95.0 mm	5	20	5	32.00 mm	14.40 mm	2.3
22J3G100088F4R00	100.00 mm	88.00 mm	110.0 mm	6	30	6	40.00 mm	16.00 mm	1.8

NOTE: Total Number of Inserts = ZNF + ZNP.



HIPOST⁺ SERIES 22J3G (WELDON SHANK)

90° ROUGH & FINISH END MILL
ALL-EFFECTIVE RH HELIX (17MM INSERT)

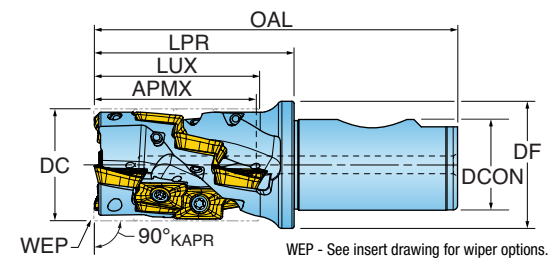

Part Number	DC Cutting Diameter	APMX Depth of Cut Max.	LUX Useable Length Max.	LPR Protruding Length	OAL Overall Length	ZNF Face Insert Count	ZNP Peripheral Insert Count	NOF Flute Count	DF Flange Diameter	DCON Shank Diameter	RMPX Ramp Angle Max.
22J3G-1502781R01	1.500	2.27	2.40	2.75	5.00	3	9	3	1.750	1.250	5
22J3G-1503381R01	1.500	2.82	3.00	3.30	5.50	3	12	3	1.750	1.250	5
22J3G-2002782R01	2.000	2.25	2.70	2.75	6.00	4	12	4	-	2.000	4
22J3G-2005082R01	2.000	4.16	4.90	5.00	8.25	4	24	4	-	2.000	4

NOTE: Total Number of Inserts = ZNF + ZNP.

HIPOST⁺ SERIES 22J3G (50 TAPER)

90° ROUGH & FINISH END MILL
ALL-EFFECTIVE RH HELIX

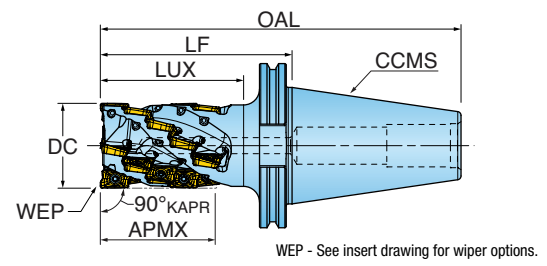

Part Number	DC Cutting Diameter	APMX Depth of Cut Max.	LUX Useable Length Max.	LF Functional Length	OAL Overall Length	ZNF Face Insert Count	ZNP Peripheral Insert Count	NOF Flute Count	CCMS Connection Code Machine Side	RMPX Ramp Angle Max..
22J3G-2004548R01	2.000	2.80	3.38	4.500	8.50	4	16	4	ICTC #50 .125 Draw	4
22J3G-2006048R01	2.000	4.16	4.88	6.000	10.00	4	24	4	ICTC #50 .125 Draw	4

NOTE: Total Number of Inserts = ZNF + ZNP.



HiPOST™ SERIES 22J3G INSERTS

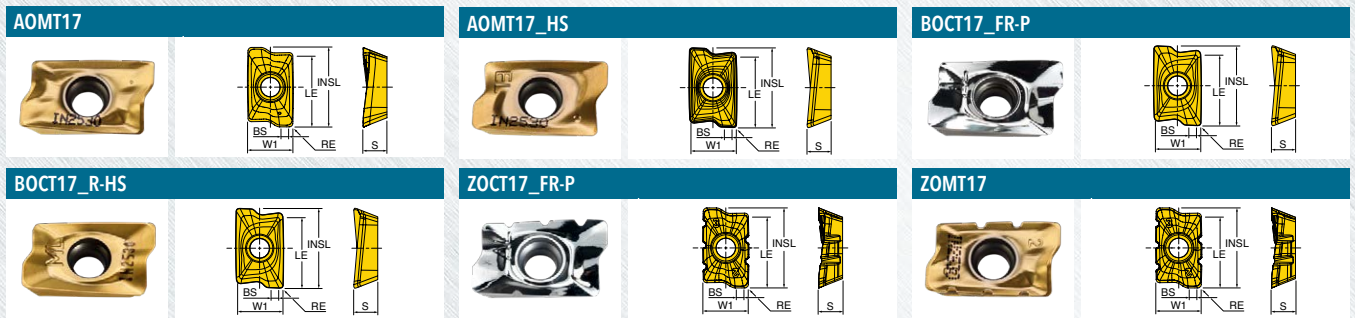
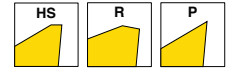

Part Number	Application	Station	RE Corner Radius	BS Wiper Length	LE Cutting Edge Length	INSL Length	W1 Width	S Thickness	Grade	IN1030	IN10K	IN2005	IN2035	IN2505	IN2510	IN2530	IN2540	IN4030	IN7035	IN6537	
AOMT170504R	Multi-Purpose	Face & Periphery	0.015 R	0.100	0.633	0.728	0.421	0.218		•						•	•				
AOMT170508R	Multi-Purpose	Face & Periphery	0.031 R	0.088	0.633	0.728	0.421	0.218		•		•		•	•	•	•	•			•
AOMT170508R-HS	SS/Hi-Temp/Ti	Face & Periphery	0.031 R	0.082	0.633	0.728	0.421	0.218		•		•	•			•					
AOMT170510R	Multi-Purpose	Face & Periphery	0.039 R	0.078	0.633	0.728	0.421	0.218								•					
AOMT170516R	Multi-Purpose	Face & Periphery	0.062 R	0.054	0.633	0.728	0.421	0.218		•		•			•	•					
AOMT170516R-HS	SS/Hi-Temp/Ti	Face & Periphery	0.062 R	0.054	0.633	0.728	0.421	0.218								•				•	
AOMT170524R	Multi-Purpose	Face	0.093 R	0.035	0.633	0.728	0.421	0.218		•		•									
BOCT170508FR-P	Grd/Pol for Al	Face & Periphery	0.031 R	0.124	0.633	0.692	0.421	0.207			•										
BOCT170508R-HS	Precision	Face & Periphery	0.031 R	0.082	0.633	0.728	0.421	0.218				•				•					
BOCT170516FR-P	Grd/Pol for Al	Face & Periphery	0.062 R	0.080	0.630	0.726	0.427	0.217			•										
ZOCT170508FR-P	Grd/Pol w/ Splitters	Face & Periphery	0.031 R	0.124	0.633	0.692	0.421	0.218			•										
ZOMT170508R	Chip Splitters	Face & Periphery	0.031 R	0.088	0.645	0.728	0.421	0.218						•	•	•					•

HIPOSTTM SERIES 22J5G

**90° ROUGH & FINISH END MILL
1/2-EFFECTIVE RH HELIX (17MM INSERT)**

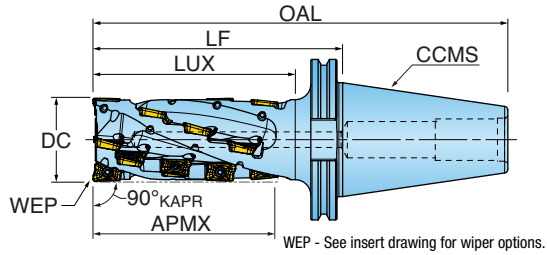

Part Number	DC Cutting Diameter	APMX Depth of Cut Max.	LUX Useable Length Max.	LF Functional Length	OAL Overall Length	ZFP Eff. Teeth Periphery	ZNF Face Insert Count	ZNP Peripheral Insert Count	NOF Flute Count	KAPR Cutting Edge Angle	CCMS Connection Code Machine Side	CSP Coolant	RMPX Ramp Angle Max.
22J5G-2006048R01	2.000	4.40	4.88	6.000	10.00	2	4	14	4	90	ICTC #50 .125 Draw	Yes	4

NOTE: Total Number of Inserts = ZNF + ZNP.
Relieve cutter body when using insert corner radii larger than R.093" (see page 41).





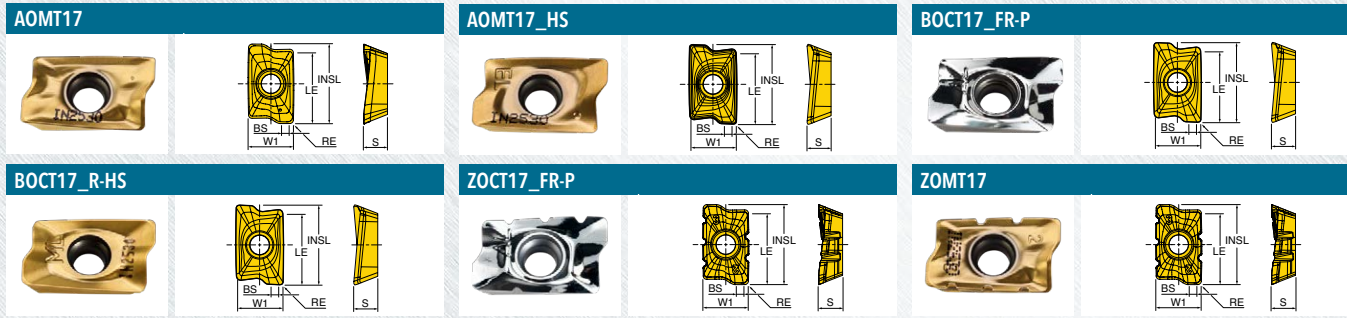
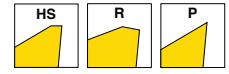





HIPOST[™] SERIES 22J5G INSERTS



Part Number	Application	Station	RE Corner Radius	BS Wiper Length	LE Cutting Edge Length	INSL Length	W1 Width	S Thickness	Grade	IN1030	IN10K	IN2005	IN2035	IN2505	IN2510	IN2530	IN2540	IN4030	IN7035	IN6537	
AOMT170504R	Multi-Purpose	Face & Periphery	0.015 R	0.100	0.633	0.728	0.421	0.218		•						•	•				
AOMT170508R	Multi-Purpose	Face & Periphery	0.031 R	0.088	0.633	0.728	0.421	0.218		•	•			•	•	•	•	•			•
AOMT170508R-HS	SS/Hi-Temp/Ti	Face & Periphery	0.031 R	0.082	0.633	0.728	0.421	0.218		•	•	•				•					
AOMT170510R	Multi-Purpose	Face & Periphery	0.039 R	0.078	0.633	0.728	0.421	0.218								•					
AOMT170516R	Multi-Purpose	Face & Periphery	0.062 R	0.054	0.633	0.728	0.421	0.218		•	•				•	•					
AOMT170516R-HS	SS/Hi-Temp/Ti	Face & Periphery	0.062 R	0.054	0.633	0.728	0.421	0.218													•
AOMT170524R	Multi-Purpose	Face	0.093 R	0.035	0.633	0.728	0.421	0.218		•	•										
AOMT170532R-HS	SS/Hi-Temp/Ti	Face & Periphery	0.125 R	0.051	0.606	0.683	0.421	0.218													•
AOMT170532R	Multi-Purpose	Face	0.125 R	0.051	0.633	0.728	0.421	0.218		•	•					•	•				
AOMT170540R	Multi-Purpose	Face	0.156 R	-	0.633	0.728	0.421	0.218		•				•							
AOMT170548R	Multi-Purpose	Face	0.187 R	-	0.633	0.728	0.421	0.218		•	•										
AOMT170550R	Multi-Purpose	Face	0.197R	-	0.596	0.664	0.421	0.218		•											
AOMT170564R-HS	SS/Hi-Temp/Ti	Face & Periphery	0.250 R	-	0.595	0.669	0.421	0.218													•
AOMT170564R	Multi-Purpose	Face	0.250 R	-	0.633	0.728	0.421	0.218		•	•				•						
BOCT170508FR-P	Grd/Pol for Al	Face & Periphery	0.031 R	0.124	0.633	0.692	0.421	0.207			•										
BOCT170530FR-P	Grd/Pol for Al	Face & Periphery	0.118 R	0.060	0.630	0.720	0.425	0.221			•										
BOCT170508R-HS	Precision	Face	0.031 R	0.082	0.633	0.728	0.421	0.218				•				•					
BOCT170516FR-P	Grd/Pol for Al	Face & Periphery	0.062 R	0.080	0.630	0.726	0.427	0.217			•										
BOCT170532FR-P	Grd/Pol for Al	Face	0.125 R	0.050	0.630	0.720	0.425	0.221			•										
BOCT170564FR-P	Grd/Pol for Al	Face	0.250 R	-	0.610	0.669	0.427	0.221			•										
ZOCT170508FR-P	Grd/Pol w/ Splitters	Face & Periphery	0.031 R	0.124	0.633	0.692	0.421	0.218			•										
ZOMT170508R	Chip Splitters	Face & Periphery	0.031 R	0.088	0.645	0.728	0.421	0.218						•	•	•					•



HIPOST™ 22J3G, 22J5G HARDWARE

								
	Insert Screw	Driver Handle	Driver Bit	Socket Head Cap Screw	Socket Set Screw	**OPTIONAL**	**OPTIONAL**	**OPTIONAL**
22J3G-20022D1R02	SM40-093-20	DS-A00T	DS-T156B	SD-06-50	-	DS-A00.25-T	DT-35-.25	DS-T15B1
22J3G-20041D3R02	SM40-093-20	DS-A00T	DS-T156B	SD-08-97	-	DS-A00.25-T	DT-35-.25	DS-T15B1
22J3G-25030D3R02	SM40-093-20	DS-A00T	DS-T156B	SD-08-52	SA030-01	DS-A00.25-T	DT-35-.25	DS-T15B1
22J3G-25040D3R02	SM40-093-20	DS-A00T	DS-T156B	SD-08-D3	SA030-01	DS-A00.25-T	DT-35-.25	DS-T15B1
22J3G-30040D4R02	SM40-093-20	DS-A00T	DS-T156B	SD-10-73	SA030-01	DS-A00.25-T	DT-35-.25	DS-T15B1
22J3G-1502781R01	SM40-093-20	DS-A00T	DS-T156B	-	-	DS-A00.25-T	DT-35-.25	DS-T15B1
22J3G-1503381R01	SM40-093-20	DS-A00T	DS-T156B	-	-	DS-A00.25-T	DT-35-.25	DS-T15B1
22J3G-2002782R01	SM40-093-20	DS-A00T	DS-T156B	-	SA030-01	DS-A00.25-T	DT-35-.25	DS-T15B1
22J3G-2005082R01	SM40-093-20	DS-A00T	DS-T156B	-	SA030-01	DS-A00.25-T	DT-35-.25	DS-T15B1
22J3G-2004548R01	SM40-093-20	DS-A00T	DS-T156B	-	SA030-01	DS-A00.25-T	DT-35-.25	DS-T15B1
22J3G-2006048R01	SM40-093-20	DS-A00T	DS-T156B	-	SA030-01	DS-A00.25-T	DT-35-.25	DS-T15B1
22J5G-2006048R01	SM40-093-20	DS-A00T	DS-T156B	-	SA030-01	DS-A00.25-T	DT-35-.25	DS-T15B1



HIPOST⁺ SERIES: 12_1R

CHAMFER END MILL (13MM INSERT)

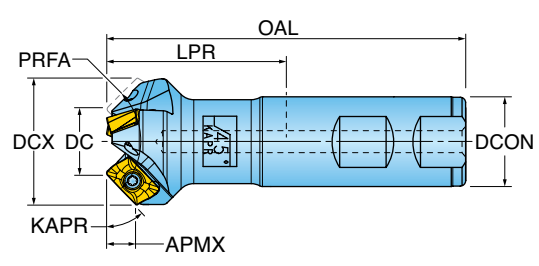

Part Number	DC Cutting Diameter	DCX Cutting Dia. Max.	KAPR Cutting Edge Angle	PRFA Profile Angle	APMX Depth of Cut Max.	LPR Projection Length	OAL Overall Length	ZEFF Effective Teeth	DCON Shank Diameter
12M1R-0701780R01	0.750	1.220	60	60	0.40	1.75	4.00	3	1.000
12N1R-0701780R01	0.750	1.408	45	90	0.32	1.75	4.00	3	1.000
12P1R-0701780R01	0.750	1.546	30	120	0.22	1.75	4.00	3	1.000
12Q1R-0701780R01	0.750	1.641	15	150	0.12	1.75	4.00	3	1.000
12L1R-0801780R01	0.875	1.123	75	30	0.46	1.75	4.00	3	1.000

METRIC

Part Number	DC Cutting Diameter	DCX Cutting Dia. Max.	KAPR Cutting Edge Angle	PRFA Profile Angle	APMX Depth of Cut Max.	LPR Projection Length	OAL Overall Length	ZEFF Effective Teeth	DCON Shank Diameter
12L1R020044W5R00	20.00 mm	26.20 mm	75	30	11.60 mm	44.0 mm	100.0 mm	3	25 mm
12M1R020044W5R00	20.00 mm	31.90 mm	60	60	10.30 mm	44.0 mm	100.0 mm	3	25 mm
12N1R020044W5R00	20.00 mm	36.90 mm	45	90	8.40 mm	44.0 mm	100.0 mm	3	25 mm
12P1R020044W5R00	20.00 mm	40.40 mm	30	120	5.90 mm	44.0 mm	100.0 mm	3	25 mm
12Q1R020044W5R00	20.00 mm	42.10 mm	15	150	2.90 mm	44.0 mm	100.0 mm	3	25 mm



HIPOST[™] 12_1R INSERTS

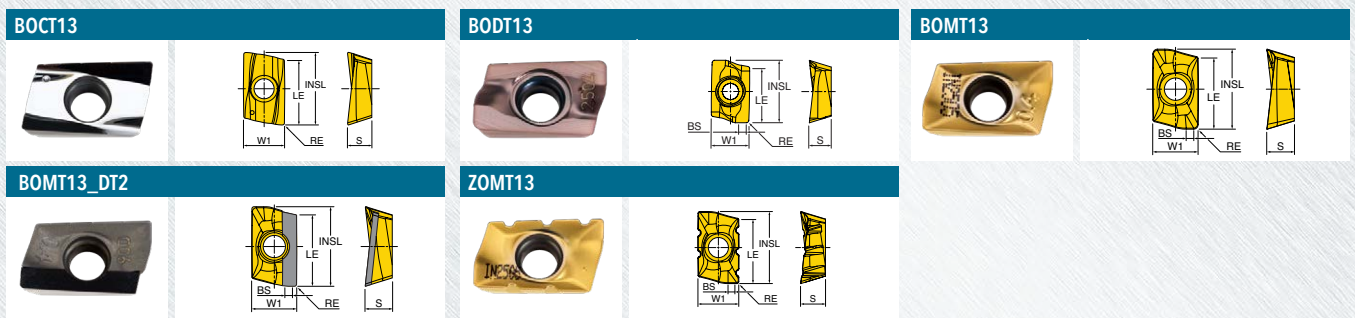
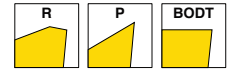

Part Number	Application	RE Corner Radius	BS Wiper Length	LE Cutting Edge Length	INSL Length	W1 Width	S Thickness	IH Insert Hand	Grade	IN10K	IN2005	IN2035	IN2504	IN2505	IN2530	IN4030	IN6535	IN90D	
BOCT130404FR-P	Grd/Pol for Al	0.015 R	-	0.490	0.557	0.320	0.189	Right	•										
BOCT130408FR-P	Grd/Pol for Al	0.031 R	-	0.490	0.555	0.319	0.187	Right	•										
BODT130408R	Neutral; Precision	0.031 R	0.076	0.490	0.558	0.320	0.190	Right		•			•						
BOMT130404R	Multi-Purpose	0.015 R	0.067	0.490	0.558	0.320	0.190	Right				•	•	•	•				
BOMT130408R	Multi-Purpose	0.031 R	0.051	0.490	0.558	0.320	0.190	Right				•	•	•	•	•			
BOMT130416R	Multi-Purpose	0.062 R	0.019	0.490	0.561	0.320	0.190	Right						•	•		•		
BOMT130404R-DT2	PCD Tipped	0.015 R	0.055	0.490	0.557	0.320	0.190	Right											•
ZOMT130404R	Positive-Splitters	0.015 R	0.067	0.490	0.558	0.320	0.190	Right						•	•				
ZOMT130408R	Positive-Splitters	0.031 R	0.051	0.490	0.561	0.320	0.190	Right						•					

HIPOST[™] 12_1R HARDWARE

	Insert Screw	Driver Handle	Driver Bit	**OPTIONAL** Torque Driver Handle	**OPTIONAL** Preset Torque Bit	**OPTIONAL** Torque Driver Bit
12M1R-0701780R01	SM35-076-10	DS-A00T	DS-T106B	DS-A00-.25-T	DT-30-.25	DS-T10B1
12N1R-0701780R01	SM35-076-10	DS-A00T	DS-T106B	DS-A00-.25-T	DT-30-.25	DS-T10B1
12P1R-0701780R01	SM35-088-10	DS-A00T	DS-T106B	DS-A00-.25-T	DT-30-.25	DS-T10B1
12Q1R-0701780R01	SM35-088-10	DS-A00T	DS-T106B	DS-A00-.25-T	DT-30-.25	DS-T10B1
12L1R-0801780R01	SM35-076-10	DS-A00T	DS-T106B	DS-A00-.25-T	DT-30-.25	DS-T10B1
12L1R020044W5R00	SM35-088-10	DS-A00T	DS-T106B	DS-A00-.25-T	DT-30-.25	DS-T10B1
12M1R020044W5R00	SM35-088-10	DS-A00T	DS-T106B	DS-A00-.25-T	DT-30-.25	DS-T10B1
12N1R020044W5R00	SM35-088-10	DS-A00T	DS-T106B	DS-A00-.25-T	DT-30-.25	DS-T10B1
12P1R020044W5R00	SM35-088-10	DS-A00T	DS-T106B	DS-A00-.25-T	DT-30-.25	DS-T10B1
12Q1R020044W5R00	SM35-088-10	DS-A00T	DS-T106B	DS-A00-.25-T	DT-30-.25	DS-T10B1



HIPOST[™] SERIES: 12N1G

45° CHAMFER END MILL (17MM INSERT)

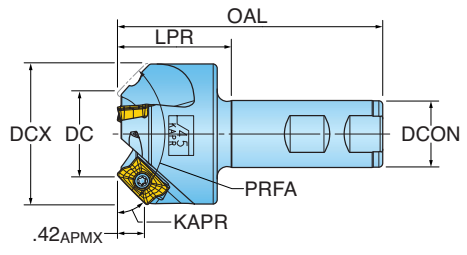

Part Number	DC Cutting Diameter	DCX Cutting Dia. Max.	KAPR Cutting Edge Angle	PRFA Profile Angle	APMX Depth of Cut Max.	LPR Projection Length	OAL Overall Length	ZEFF Effective Teeth	DCON Shank Diameter	CSP Coolant
12N1G-1201780R01	1.250	2.118	45	90	0.425	1.75	4.00	3	1.000	Yes



HIPOST™ 12N1G INSERTS

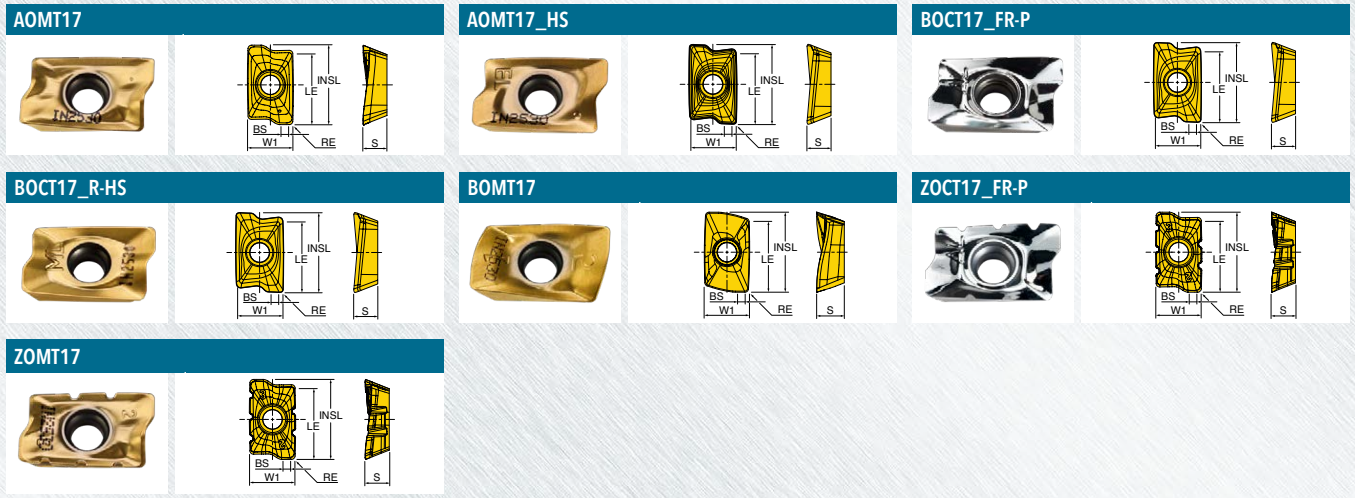
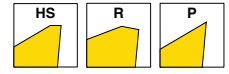

Part Number	Application	RE Corner Radius	BS Wiper Length	LE Cutting Edge Length	INSL Length	W1 Width	S Thickness	Grade	IN1030	IN10K	IN2005	IN2035	IN2504	IN2505	IN2510	IN2530	IN2540	IN4030	IN7035	IN6537	
AOMT170504R	Multi-Purpose	0.015 R	0.100	0.633	0.728	0.421	0.218		•							•	•				
AOMT170508R	Multi-Purpose	0.031 R	0.088	0.633	0.728	0.421	0.218		•		•			•	•	•	•	•			•
AOMT170508R-HS	SS/Hi-Temp/Ti	0.031 R	0.082	0.633	0.728	0.421	0.218		•		•	•				•					
AOMT170510R	Multi-Purpose	0.039 R	0.078	0.633	0.728	0.421	0.218									•					
AOMT170516R	Multi-Purpose	0.062 R	0.054	0.633	0.728	0.421	0.218		•		•				•	•					
AOMT170516R-HS	SS/Hi-Temp/Ti	0.062 R	0.054	0.633	0.728	0.421	0.218									•				•	
BOCT170508FR-P	Grd/Pol for Al	0.031 R	0.124	0.633	0.692	0.421	0.207			•											
BOCT170508R-HS	Precision	0.031 R	0.082	0.633	0.728	0.421	0.218				•					•					
BOMT170608R	Heavy Duty	0.031 R	0.086	0.630	0.744	0.421	0.256					•	•	•	•	•	•				
ZOCT170508FR-P	Grd/Pol w/ Splitters	0.031 R	0.124	0.633	0.692	0.421	0.218			•											
ZOMT170508R	Multi-Purpose Splitters	0.031 R	0.088	0.645	0.728	0.421	0.218					•		•		•					•

HIPOST™ 12N1G HARDWARE

	Insert Screw	Driver Handle	Driver Bit	Torque Driver Handle	Preset Torque Bit	Torque Driver Bit
12N1G-1201780R01	SM40-120-20	DS-A00T	DS-T156B	DS-A00.25-T	DT-35-.25	DS-T15B1

HIPOST™ SERIES: 22_3R

CHAMFER SHELL MILL (13MM INSERT)



Chamfer



Coolant

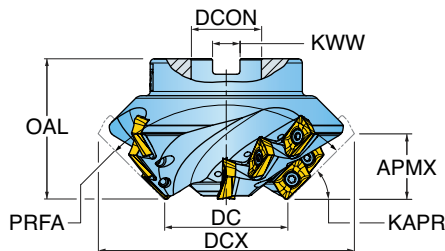

Part Number	DC Cutting Diameter	DCX Cutting Dia. Max.	KAPR Cutting Edge Angle	PRFA Profile Angle	APMX Depth of Cut Max.	OAL Overall Length	ZNF Face Inserts	ZNP Peripheral Inserts	NOF Flute Count	DCON Shank Diameter	KWW Keyway
22L3R-17020D3R01	1.750	2.445	75	30	1.29	2.00	4	8	4	1.000	0.375
22M3R-17020D3R01	1.750	3.082	60	60	1.15	2.00	4	8	4	1.000	0.375
22N3R-17020D3R01	1.750	3.621	45	90	0.93	2.00	4	8	4	1.000	0.375
22P3R-17020D4R01	1.750	4.034	30	120	0.66	2.00	4	8	4	1.250	0.500
22Q3R-17020D4R01	1.750	4.305	15	150	0.34	2.00	4	8	4	1.250	0.500

METRIC

Part Number	DC Cutting Diameter	DCX Cutting Dia. Max.	KAPR Cutting Edge Angle	PRFA Profile Angle	APMX Depth of Cut Max.	OAL Overall Length	ZNF Face Inserts	ZNP Peripheral Inserts	NOF Flute Count	DCON Shank Diameter	KWW Keyway
22L3R045050F1R00	45.00 mm	63.20 mm	75	30	33.90 mm	50.0 mm	4	8	4	22.00 mm	10.40 mm
22M3R045050F2R00	45.00 mm	80.00 mm	60	60	30.20 mm	50.0 mm	4	8	4	27.00 mm	12.40 mm
22N3R045050F2R00	45.00 mm	94.40 mm	45	90	24.60 mm	50.0 mm	4	8	4	27.00 mm	12.40 mm
22P3R045050F2R00	45.00 mm	105.40 mm	30	120	17.30 mm	50.0 mm	4	8	4	27.00 mm	12.40 mm
22Q3R045050F2R00	45.00 mm	112.50 mm	15	150	9.00 mm	50.0 mm	4	8	4	27.00 mm	12.40 mm



HIPOST™ 22_3R INSERTS

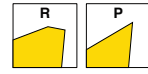

Part Number	Application	RE Corner Radius	BS Wiper Length	LE Cutting Edge Length	INSL Length	W1 Width	S Thickness	IH Insert Hand	Grade	IN10K	IN2035	IN2504	IN2505	IN2530	IN4030
BOCT130404FR-P	Grd/Pol for Al	0.015 R	-	0.490	0.557	0.320	0.189	Right	•						
BOCT130408FR-P	Grd/Pol for Al	0.031 R	-	0.490	0.555	0.319	0.187	Right	•						
BOMT130404R	Multi-Purpose	0.015 R	0.067	0.490	0.558	0.320	0.190	Right			•		•	•	•
BOMT130408R	Multi-Purpose	0.031 R	0.051	0.490	0.558	0.320	0.190	Right			•	•	•	•	•
ZOMT130404R	Positive-Splitters	0.015 R	0.067	0.490	0.558	0.320	0.190	Right					•	•	
ZOMT130408R	Positive-Splitters	0.031 R	0.051	0.490	0.561	0.320	0.190	Right					•		

HIPOST™ 22_3R HARDWARE

	Insert Screw	Driver Handle	Driver Bit	**OPTIONAL** Torque Driver Handle	**OPTIONAL** Preset Torque Bit	**OPTIONAL** Torque Driver Bit
22L3R-17020D3R01	SM35-088-10	DS-A00T	DS-T106B	DS-A00-.25-T	DT-30-.25	DS-T10B1
22M3R-17020D3R01	SM35-088-10	DS-A00T	DS-T106B	DS-A00-.25-T	DT-30-.25	DS-T10B1
22N3R-17020D3R01	SM35-088-10	DS-A00T	DS-T106B	DS-A00-.25-T	DT-30-.25	DS-T10B1
22P3R-17020D4R01	SM35-088-10	DS-A00T	DS-T106B	DS-A00-.25-T	DT-30-.25	DS-T10B1
22Q3R-17020D4R01	SM35-088-10	DS-A00T	DS-T106B	DS-A00-.25-T	DT-30-.25	DS-T10B1
22L3R045050F1R00	SM35-088-10	DS-A00T	DS-T106B	DS-A00-.25-T	DT-30-.25	DS-T10B1
22M3R045050F2R00	SM35-088-10	DS-A00T	DS-T106B	DS-A00-.25-T	DT-30-.25	DS-T10B1
22N3R045050F2R00	SM35-088-10	DS-A00T	DS-T106B	DS-A00-.25-T	DT-30-.25	DS-T10B1
22P3R045050F2R00	SM35-088-10	DS-A00T	DS-T106B	DS-A00-.25-T	DT-30-.25	DS-T10B1
22Q3R045050F2R00	SM35-088-10	DS-A00T	DS-T106B	DS-A00-.25-T	DT-30-.25	DS-T10B1

Hi-Pos+™ SERIES: 12L1P

70° ROUGHING END MILL (9MM INSERT)

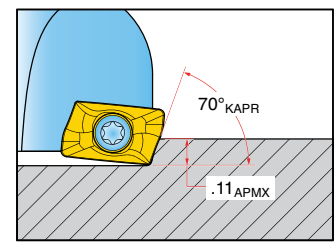
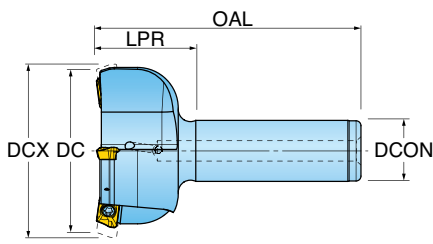

Part Number	DC Cutting Diameter	DCX Cutting Dia. Max.	KAPR Cutting Edge Angle	APMX Depth of Cut Max.	LPR Projection Length	OAL Overall Length	ZEFF Effective Teeth	DCON Shank Diameter	CSP Coolant
12L1P-20012S7R01	2.000	2.130	70	0.12	1.25	3.25	3	0.750	Yes

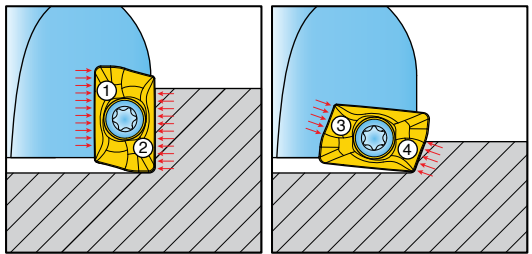

When using the Hi-Pos+ milling family, it is possible to make use of all four cutting edges. The first 2 edges can be used in any Hi-Pos+ 90° or lead angle endmill or facemill, then use edges 3 and 4 in 12L endmills or 2L facemills.



HIPOST[™] 12L1P INSERTS

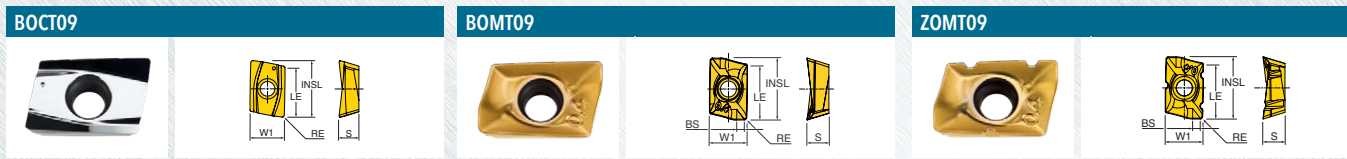

Part Number	Application	Insert Station	RE Corner Radius	BS Wiper Length	LE Cutting Edge Length	INSL Length	W1 Width	S Thickness	Grade	IN10K	IN2010	IN2035	IN2504	IN2505	IN2530	IN4030
BOCT09T304FR-P	Grd/Pol for Al	End/Side	0.015 R	-	0.350	0.417	0.260	0.146		•						
BOCT09T308FR-P	Grd/Pol for Al	End/Side	0.031 R	-	0.350	0.414	0.260	0.144		•						
BOMT09T304R	Multi-Purpose	End/Side	0.015 R	0.050	0.350	0.421	0.258	0.148			•			•	•	•
BOMT09T308R	Multi-Purpose	End/Side	0.031 R	0.034	0.350	0.421	0.259	0.148				•	•	•	•	•
BOMT09T316R	Multi-Purpose	End	0.062 R	-	0.350	0.421	0.259	0.148				•		•	•	
BOMT09T320R	Multi-Purpose	End	0.079 R	-	0.350	0.421	0.259	0.148						•		
BOMT09T331R	Multi-Purpose	End	0.120 R	-	0.350	0.421	0.259	0.148					•	•	•	
ZOMT09T304R	Positive-Splitters	End/Side	0.015 R	0.050	0.350	0.421	0.259	0.148					•		•	•

HIPOST[™] 12L1P HARDWARE

	Insert Screw	Screw Driver	Torque Driver Handle	Preset Torque Bit	Torque Driver Bit
12L1P-2001257R01	SM25-064-00	DS-T08W	DS-A00-.25-S	DT-11-.25	DS-T08B



Hi-Pos+™ SERIES: 12L1R

70° ROUGHING END MILL (13MM INSERT)

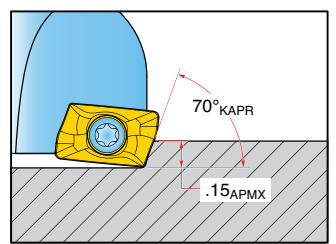
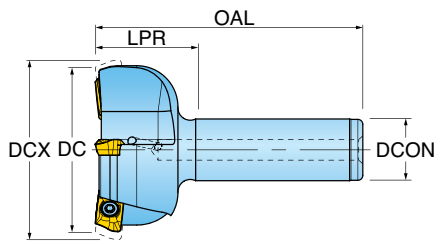

Part Number	DC Cutting Diameter	DCX Cutting Dia. Max.	KAPR Cutting Edge Angle	APMX Depth of Cut Max.	LPR Projection Length	OAL Overall Length	ZEFF Effective Teeth	DCON Shank Diameter	CSP Coolant
12L1R-20012S7R01	2.000	2.170	70	0.15	1.25	3.25	3	0.750	Yes

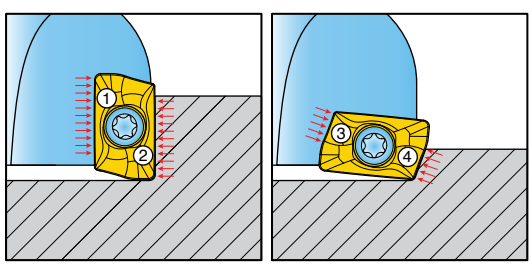

When using the Hi-Pos+ milling family, it is possible to make use of all four cutting edges. The first 2 edges can be used in any Hi-Pos+ 90° or lead angle endmill or facemill, then use edges 3 and 4 in 12L endmills or 2L facemills.



HIPOST[™] 12L1R INSERTS

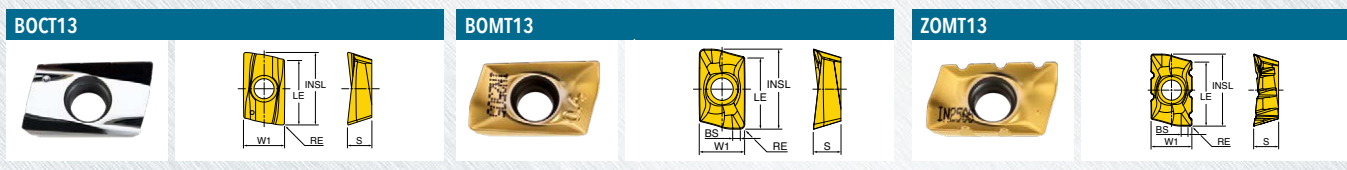

Part Number	Application	RE Corner Radius	BS Wiper Length	LE Cutting Edge Length	INSL Length	W1 Width	S Thickness	IH Insert Hand	Grade	IN10K	IN2035	IN2504	IN2505	IN2530	IN4030	IN6535
BOCT130404FR-P	Grd/Pol for Al	0.015 R	-	0.490	0.557	0.320	0.189	Right		•						
BOCT130408FR-P	Grd/Pol for Al	0.031 R	-	0.490	0.555	0.319	0.187	Right		•						
BOMT130404R	Multi-Purpose	0.015 R	0.067	0.490	0.558	0.320	0.190	Right			•		•	•	•	
BOMT130408R	Multi-Purpose	0.031 R	0.051	0.490	0.558	0.320	0.190	Right			•	•	•	•	•	
BOMT130416R	Multi-Purpose	0.062 R	0.019	0.490	0.561	0.320	0.190	Right					•	•		
BOMT130420R	Multi-Purpose	0.078 R	-	0.490	0.561	0.320	0.190	Right					•	•		
BOMT130424R	Multi-Purpose	0.093 R	-	0.490	0.560	0.320	0.190	Right					•	•		
BOMT130431R	Multi-Purpose	0.125 R	-	0.480	0.546	0.320	0.180	Right			•		•	•		
BOMT130440R	Multi-Purpose	0.156 R	-	0.480	0.538	0.320	0.183	Right					•			
ZOMT130404R	Positive-Splitters	0.015 R	0.067	0.490	0.558	0.320	0.190	Right					•	•		
ZOMT130408R	Positive-Splitters	0.031 R	0.051	0.490	0.561	0.320	0.190	Right					•			

HIPOST[™] 12L1R HARDWARE

	Insert Screw	Driver Handle	Driver Bit	**OPTIONAL** Torque Driver Handle	**OPTIONAL** Preset Torque Bit	**OPTIONAL** Torque Driver Bit
12L1R-20012S7R01	SM35-088-10	DS-A00T	DS-T106B	DS-A00-.25-T	DT-30-.25	DS-T10B1

HI·POST⁺ SERIES: 12L1G

75° ROUGHING END MILL (17MM INSERT)

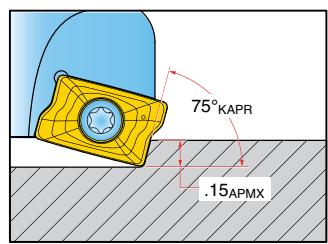
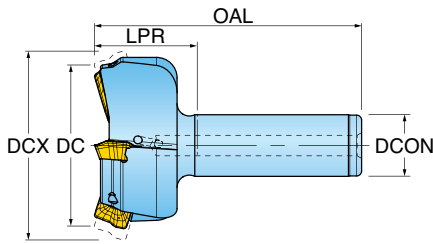

Part Number	DC Cutting Diameter	DCX Cutting Dia. Max.	KAPR Cutting Edge Angle	APMX Depth of Cut Max.	LPR Projection Length	OAL Overall Length	ZEFF Effective Teeth	DCON Shank Diameter	CSP Coolant
12L1G-20012S7R01	2.000	2.300	75	0.15	1.25	3.25	3	0.750	Yes

HI·POST⁺ SERIES: 2L1G

75° ROUGHING FACE MILL (17MM INSERT)

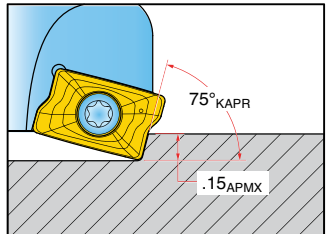
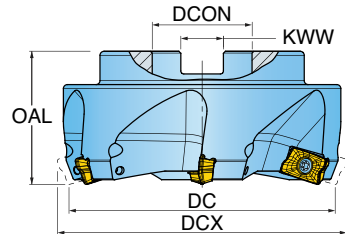

Part Number	DC Cutting Diameter	DCX Cutting Dia. Max.	KAPR Cutting Edge Angle	APMX Depth of Cut Max.	OAL Overall Length	ZEFF Effective Teeth	DCON Bore Diameter	KWW Keyway	CSP Coolant
2L1G-40R01	4.000	4.35	75.0	0.15	2.000	6	1.500	0.625	No

Hi-Pos+™ 12L1G, 2L1G INSERTS

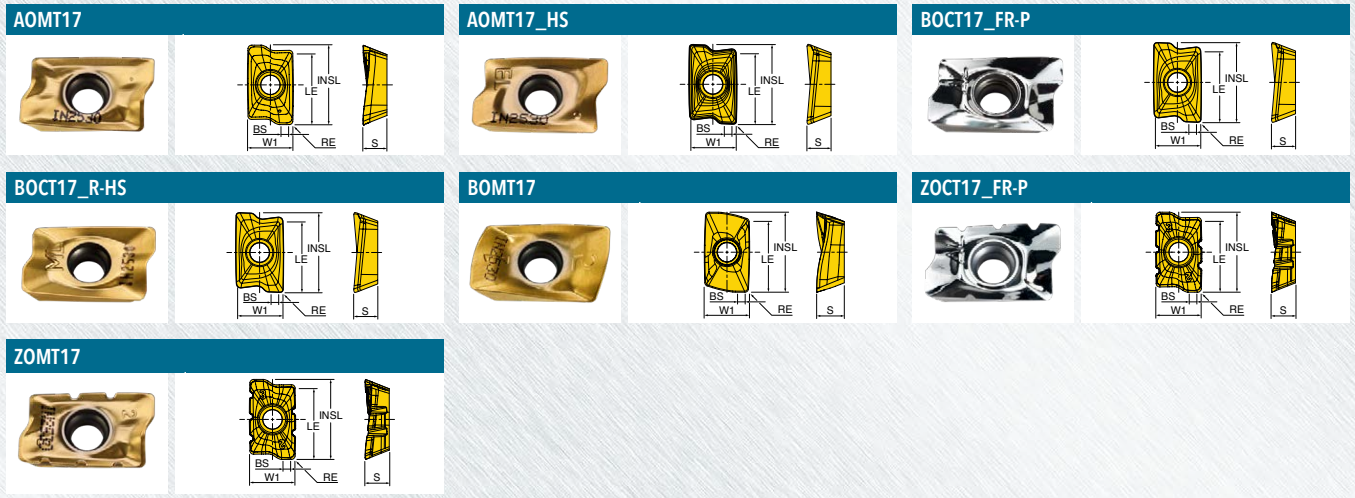
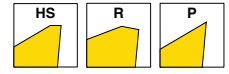



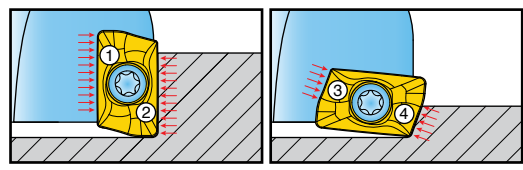



Part Number	Application	RE Corner Radius	BS Wiper Length	LE Cutting Edge Length	INSL Length	W1 Width	S Thickness	Grade	IN1030	IN10K	IN2005	IN2035	IN2504	IN2505	IN2510	IN2530	IN2540	IN4030	IN7035	IN6537
AOMT170504R	Multi-Purpose	0.015 R	0.100	0.633	0.728	0.421	0.218		•							•	•			
AOMT170508R	Multi-Purpose	0.031 R	0.088	0.633	0.728	0.421	0.218		•		•			•	•	•	•	•		•
AOMT170508R-HS	SS/Hi-Temp/Ti	0.031 R	0.082	0.633	0.728	0.421	0.218		•		•	•				•				
AOMT170510R	Multi-Purpose	0.039 R	0.078	0.633	0.728	0.421	0.218									•				
AOMT170516R	Multi-Purpose	0.062 R	0.054	0.633	0.728	0.421	0.218		•		•				•	•				
AOMT170516R-HS	SS/Hi-Temp/Ti	0.062 R	0.054	0.633	0.728	0.421	0.218									•				•
AOMT170524R	Multi-Purpose	0.093 R	0.035	0.633	0.728	0.421	0.218		•		•									
AOMT170532R	Multi-Purpose	0.125 R	0.051	0.633	0.728	0.421	0.218		•		•					•	•			
AOMT170532R-HS	SS/Hi-Temp/Ti	0.125 R	0.051	0.606	0.683	0.421	0.218									•				•
AOMT170540R	Multi-Purpose	0.156 R	-	0.633	0.728	0.421	0.218		•					•						
AOMT170548R	Multi-Purpose	0.187 R	-	0.633	0.728	0.421	0.218		•		•									
AOMT170550R	Multi-Purpose	0.197 R	-	0.596	0.664	0.421	0.218		•											
AOMT170564R	Multi-Purpose	0.250 R	-	0.633	0.728	0.421	0.218		•		•				•					
AOMT170564R-HS	SS/Hi-Temp/Ti	0.250 R	-	0.595	0.669	0.421	0.218									•				•
BOCT170508FR-P	Grd/Pol for Al	0.031 R	0.124	0.633	0.692	0.421	0.207			•										
BOCT170530FR-P	Grd/Pol for Al	0.118 R	0.060	0.630	0.720	0.425	0.221			•										
BOCT170508R-HS	Precision	0.031 R	0.082	0.633	0.728	0.421	0.218				•					•				
BOCT170516FR-P	Grd/Pol for Al	0.062 R	0.080	0.630	0.726	0.427	0.217			•										
BOCT170532FR-P	Grd/Pol for Al	0.125 R	0.050	0.630	0.720	0.425	0.221			•										
BOCT170564FR-P	Grd/Pol for Al	0.250 R	-	0.610	0.669	0.425	0.221			•										
BOMT170608R	Heavy Duty	0.031 R	0.086	0.630	0.744	0.421	0.256					•	•	•	•	•				
ZOCT170508FR-P	Grd/Pol w/ Splitters	0.031 R	0.124	0.633	0.692	0.421	0.218			•										
ZOMT170508R	Multi-Purpose Splitters	0.031 R	0.088	0.645	0.728	0.421	0.218					•		•		•				•



When using the Hi-Pos+ milling family, it is possible to make use of all four cutting edges. The first 2 edges can be used in any Hi-Pos+ 90° or lead angle endmill or facemill, then use edges 3 and 4 in 12L endmills or 2L facemills.



HIPOST™ 12L1G, 2L1G HARDWARE

						
	Insert Screw	Driver Handle	Driver Bit	**OPTIONAL**	**OPTIONAL**	**OPTIONAL**
12L1G-20012S7R01	SM40-120-20	DS-A00T	DS-T156B	DS-A00.25-T	DT-35-.25	DS-T15B1
2L1G-40R01	SM40-120-20	DS-A00T	DS-T156B	DS-A00.25-T	DT-35-.25	DS-T15B1

HIPOST⁺ CHIP SPLITTER INFORMATION

- Draws less horsepower
- Reduces cutting force and vibration/chatter
- Improves chip evacuation (Chips split into small pieces)
- Reduces heat generation
- Suitable for long overhang machining (Weak machining and fixture applications)
- Mountable on all standard cutter lines without any modification



Side A



Side B

With 2 Grooves



With 3 Grooves

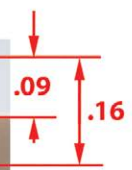
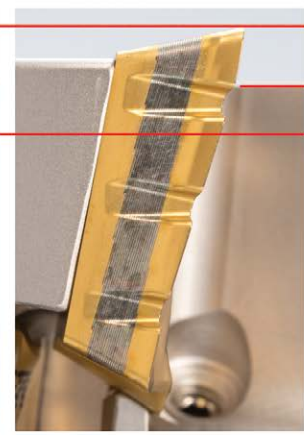

For best performance and surface finish results, alternate grooves from one flute to the next.



The number "3" designates the number of chip splitters presented on the OD of the entire flute

The number "2" designates the number of chip splitters presented on the OD of the entire flute



CUTTER BODY MODIFICATION FOR LARGE RADIUS INSERTS

When using an insert radius larger than indicated per Insert IC, check to ensure the cutter body does not protrude beyond the trailing edge of the insert. If it does, the housing corner can be modified on a lathe or grinder by removing material from the face and enlarging the corner radius (illustrated below).

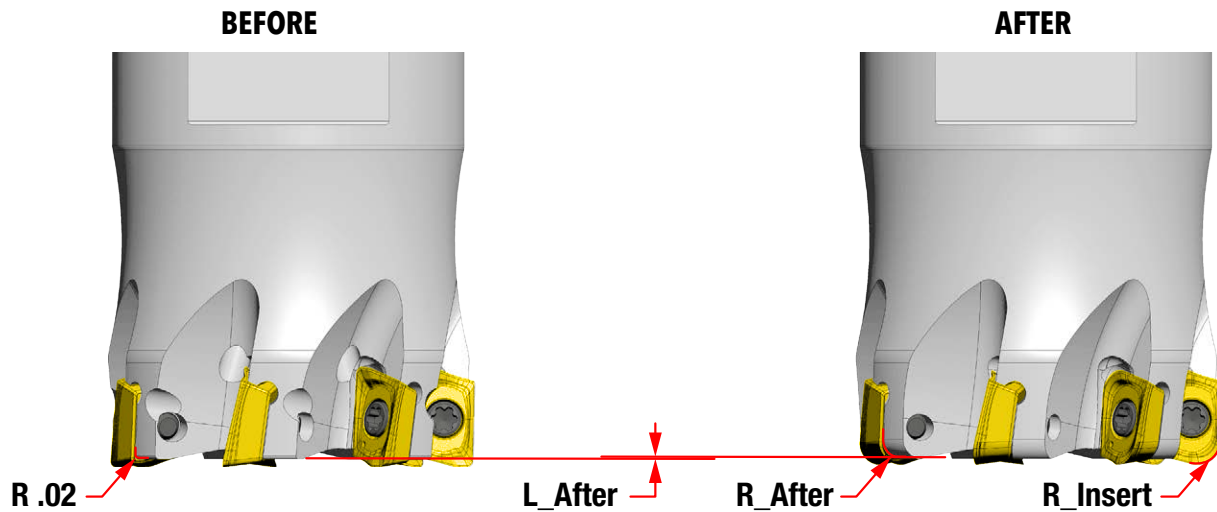

Insert Size	Modify Cutter Body If Insert Radius Exceeds	R_Insert	L_After	R_After
9mm	.062"	0.078	0	0.050
		0.120	0.003	0.095
13mm	.078"	0.093	0	0.084
		0.125	0	0.100
		0.156	0.007	0.150
17mm	.093"	0.125	0.025	0.115
		0.156	0.025	0.115
		0.187	0.025	0.115
		0.250	0.025	0.197



HIPOST™ OPERATING GUIDELINES - SERIES 12J1P, 12L1P, 2J1P

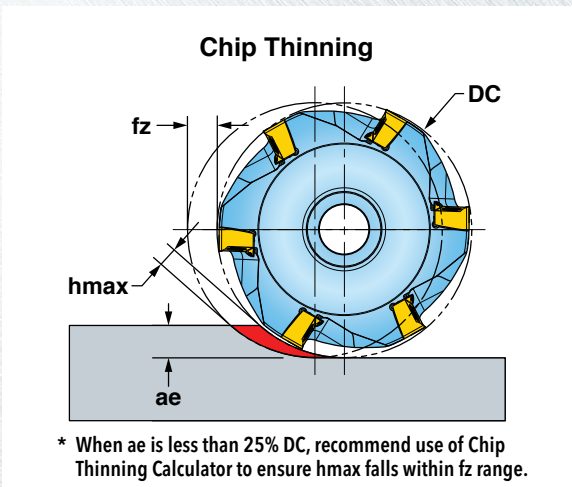

ISO	Materials			V _c Cutting Speed SFM	f _z Feed/Tooth (inch)	Harder <-----> Tougher							Coolant
	Mat'l Group #VDI 3323	Type	Examples			IN90D	IN2504	IN10K	IN2010	IN2505 IN2005	IN4030 IN2530	IN2035	
P	1 thru 5	Non-alloy Steel	1018, A36, 1045, A572, 1070	400-1000	.003-.006	3			2	1		NO	
	6 thru 9	Low-alloy Steel	4140, 4340, P20, 8620, 300M	350-700									
	10, 11	High-alloy Steel	H13, A2, D2, M2, T1	300-600									
M	12 thru 13	Stainless Steel (Ferritic & Martensitic)	410, 416, 440	350-600	.003-.005				3	2	1	YES	
	14	Stainless Steel (Austenitic)	303, 304, 316, 15-5, 17-4	300-550								May not be required at high speeds	
K	15 thru 16	Gray Cast Iron	CLS. 20, 30, 45	500-1000	.003-.006	2		1	3			NO	
	17 thru 20	Nodular Cast Iron	60-40-18, 100-70-03	400-800									
N	21 thru 30	Aluminum	7075, 6061	1000-3000	.003-.007	1	1					YES	
S	31 thru 35	High-Temp Alloys	Inconel, Hastelloy, Nimonic, Monel	65-150	.003-.005				2	3	1	YES	
	36 thru 37	Titanium Alloys	6Al-4V, 5Al-5Mo-5V-3Cr	85-200					3	2	1		
H	38 thru 39	Hardened Steel >48	A2, 01, D2	130-250	.003-.004	1			2			NO	

Note: Feed and speed recommendations are starting operating parameters. They are only guidelines from which further optimization should take place. Operating parameters are influenced by many machining variables. These variables may cause for reductions in feeds and speed or dramatic increases. Additionally, DOC and WOC may need to be revised to optimize the tools performance.

HIPOST™ OPERATING GUIDELINES - SERIES 22J3P

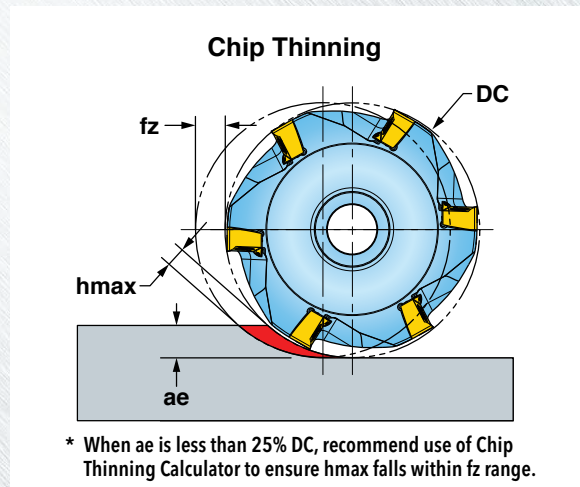

ISO	Materials			V _c Cutting Speed SFM	f _z Feed/Tooth (inch)	Harder <-----> Tougher						Coolant
	Mat'l Group #VDI 3323	Type	Examples			IN2504	IN10K	IN2010	IN2505	IN4030 IN2530	IN2035	
P	1 thru 5	Non-alloy Steel	1018, A36, 1045, A572, 1070	300-600	.003-.005	3			2	1	NO	
	6 thru 9	Low-alloy Steel	4140, 4340, P20, 8620, 300M	250-500								
	10, 11	High-alloy Steel	H13, A2, D2, M2, T1	250-450								
M	12 thru 13	Stainless Steel (Ferritic & Martensitic)	410, 416, 440	300-500	.003-.004			3	2	1	YES	
	14	Stainless Steel (Austenitic)	303, 304, 316, 15-5, 17-4	250-450							May not be required at high speeds	
K	15 thru 16	Gray Cast Iron	CLS. 20, 30, 45	300-600	.003-.005	1		2	3		NO	
	17 thru 20	Nodular Cast Iron	60-40-18, 100-70-03	300-500								
N	21 thru 30	Aluminum	7075, 6061	800-1500	.003-.006		1				YES	
S	31 thru 35	High-Temp Alloys	Inconel, Hastelloy, Nimonic, Monel	50-120	.003-.004			2	3	1	YES	
	36 thru 37	Titanium Alloys	6AL-4V, 5Al-5Mo-5V-3Cr	60-130								3

Note: Feed and speed recommendations are starting operating parameters. They are only guidelines from which further optimization should take place. Operating parameters are influenced by many machining variables. These variables may cause for reductions in feeds and speed or dramatic increases. Additionally, DOC and WOC may need to be revised to optimize the tools performance.



HIPOST™ OPERATING GUIDELINES - SERIES 12J1R, 12L1R & 2J1R

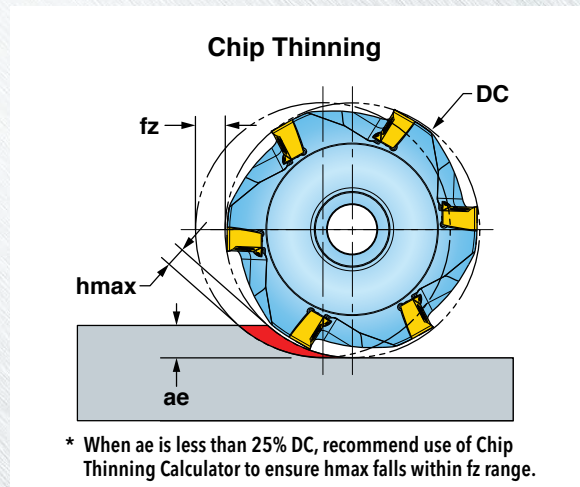

ISO	Materials			V _c Cutting Speed SFM	f _z Feed/Tooth (inch)	Harder <-----> Tougher						Coolant
	Mat'l Group #VDI 3323	Type	Examples			IN90D	IN2504	IN10K	IN2505 IN2005	IN4030 IN2530	IN6535 IN2035	
P	1 thru 5	Non-alloy Steel	1018, A36, 1045, A572, 1070	400-1000	.003-.007							NO
	6 thru 9	Low-alloy Steel	4140, 4340, P20, 8620, 300M	350-700		3	2	1				
	10, 11	High-alloy Steel	H13, A2, D2, M2, T1	300-600								
M	12 thru 13	Stainless Steel (Ferritic & Martensitic)	410, 416, 440	350-600	.003-.006			3	2	1	YES	
	14	Stainless Steel (Austenitic)	303, 304, 316, 15-5, 17-4	300-550							May not be required at high speeds	
K	15 thru 16	Gray Cast Iron	CLS. 20, 30, 45	500-1000	.003-.007		1	2			NO	
	17 thru 20	Nodular Cast Iron	60-40-18, 100-70-03	400-800								
N	21 thru 30	Aluminum	7075, 6061	1000-3000	.003-.008	1	1				YES	
S	31 thru 35	High-Temp Alloys	Inconel, Hastelloy, Nimonic, Monel	65-150	.003-.005			2	3	1	YES	
	36 thru 37	Titanium Alloys	6AL-4V, 5Al-5Mo-5V-3Cr	85-200				3	2	1		
H	38 thru 39	Hardened Steel >48	A2, 01, D2	130-250	.003-.004		1	2			NO	

Note: Feed and speed recommendations are starting operating parameters. They are only guidelines from which further optimization should take place. Operating parameters are influenced by many machining variables. These variables may cause for reductions in feeds and speed or dramatic increases. Additionally, DOC and WOC may need to be revised to optimize the tools performance.

HIPOST™ OPERATING GUIDELINES - SERIES 22J3R

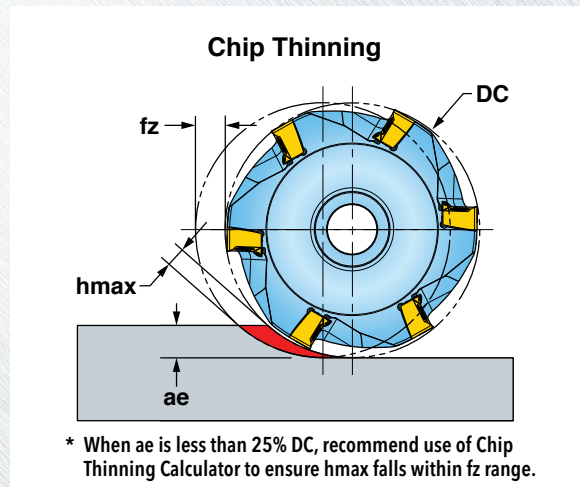

ISO	Materials			V _c Cutting Speed SFM	f _z Feed/Tooth (inch)	Harder <-----> Tougher					Coolant
	Mat'l Group #VDI 3323	Type	Examples			IN2504	IN10K	IN2505	IN4030 IN2530	IN6535 IN2035	
P	1 thru 5	Non-alloy Steel	1018, A36, 1045, A572, 1070	300-600	.003-.006	3	2	1		NO	
	6 thru 9	Low-alloy Steel	4140, 4340, P20, 8620, 300M	250-500							
	10, 11	High-alloy Steel	H13, A2, D2, M2, T1	250-450							
M	12 thru 13	Stainless Steel (Ferritic & Martensitic)	410, 416, 440	300-500	.003-.005		3	2	1	YES	
	14	Stainless Steel (Austenitic)	303, 304, 316, 15-5, 17-4	250-450						May not be required at high speeds	
K	15 thru 16	Gray Cast Iron	CLS. 20, 30, 45	300-600	.003-.006	1	2			NO	
	17 thru 20	Nodular Cast Iron	60-40-18, 100-70-03	300-500							
N	21 thru 30	Aluminum	7075, 6061	800-1500	.003-.007	1				YES	
S	31 thru 35	High-Temp Alloys	Inconel, Hastelloy, Nimonic, Monel	50-120	.003-.005		2	3	1	YES	
	36 thru 37	Titanium Alloys	6Al-4V, 5Al-5Mo-5V-3Cr	60-130							3

Note: Feed and speed recommendations are starting operating parameters. They are only guidelines from which further optimization should take place. Operating parameters are influenced by many machining variables. These variables may cause for reductions in feeds and speed or dramatic increases. Additionally, DOC and WOC may need to be revised to optimize the tools performance.

HIPOST™ OPERATING GUIDELINES - SERIES 12_1R, 12_1G

RPM Calculation

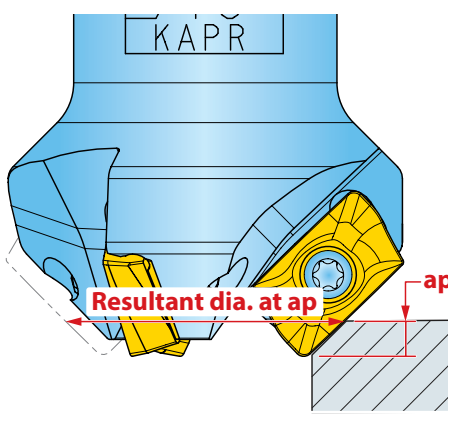

Calculation is to be made using the resultant diameter at ap.

Chip Thinning

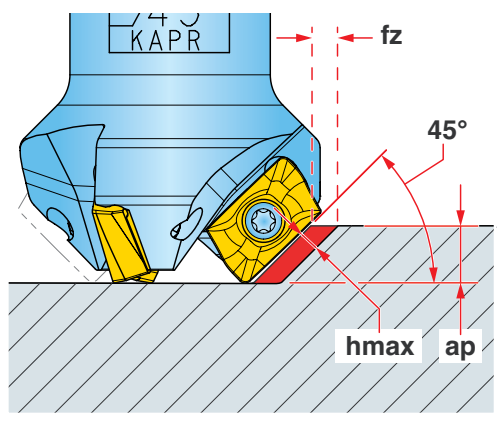

Chip Thinning Calculator is recommended to ensure hmax falls within fz range.

ISO	Materials			V _c Cutting Speed SFM	f _z Feed/Tooth (inch)	Harder <-----> Tougher										Coolant			
	Mat'l Group #VDI 3323	Type	Examples			IN90D	IN2504	IN2540	IN10K	IN2510	IN2505	IN2005	IN4030	IN2530	IN1030		IN7035	IN6535	IN2035
P	1 thru 5	Non-alloy Steel	1018, A36, 1045, A572, 1070	400-1000	.003-.007														NO
	6 thru 9	Low-alloy Steel	4140, 4340, P20, 8620, 300M	350-700		5	4				3	2					1		
	10, 11	High-alloy Steel	H13, A2, D2, M2, T1	300-600															
M	12 thru 13	Stainless Steel (Ferritic & Martensitic)	410, 416, 440	350-600	.003-.006														YES May not be required at high speeds
	14	Stainless Steel (Austenitic)	303, 304, 316, 15-5, 17-4	300-550			4				3	2	1						
K	15 thru 16	Gray Cast Iron	CLS. 20, 30, 45	500-1000	.003-.007														NO
	17 thru 20	Nodular Cast Iron	60-40-18, 100-70-03	400-800		1			2	3									
N	21 thru 30	Aluminum	7075, 6061	1000-3000	.003-.008	1			1									YES	
S	31 thru 35	High-Temp Alloys	Inconel, Hastelloy, Nimonic, Monel	65-150	.003-.005						2	3	1					YES	
	36 thru 37	Titanium Alloys	6AL-4V, 5Al-5Mo-5V-3Cr	85-200							3	2	1						
H	38 thru 39	Hardened Steel >48	A2, 01, D2	130-250	.003-.004		1				2							NO	

Note: Feed and speed recommendations are starting operating parameters. They are only guidelines from which further optimization should take place. Operating parameters are influenced by many machining variables. These variables may cause for reductions in feeds and speed or dramatic increases. Additionally, DOC and WOC may need to be revised to optimize the tools performance.

HIPOST™ OPERATING GUIDELINES - SERIES 22_3R

RPM Calculation

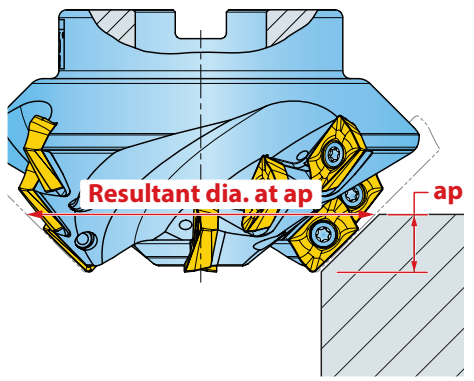

Calculation is to be made using the resultant diameter at ap.

Chip Thinning

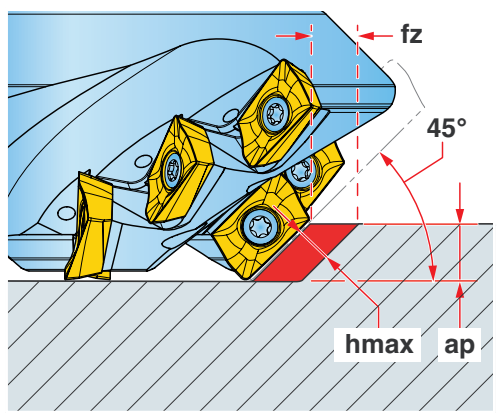

Chip Thinning Calculator is recommended to ensure hmax falls within fz range.

ISO	Materials			V _c Cutting Speed SFM	f _z Feed/Tooth (inch)	Harder <-----> Tougher					Coolant
	Mat'l Group #VDI 3323	Type	Examples			IN2504	IN10K	IN2505	IN4030 IN2530	IN6535 IN2035	
P	1 thru 5	Non-alloy Steel	1018, A36, 1045, A572, 1070	300-600	.003-.006	3	2	1			NO
	6 thru 9	Low-alloy Steel	4140, 4340, P20, 8620, 300M	250-500							
	10, 11	High-alloy Steel	H13, A2, D2, M2, T1	250-450							
M	12 thru 13	Stainless Steel (Ferritic & Martensitic)	410, 416, 440	300-500	.003-.005		3	2	1		YES
	14	Stainless Steel (Austenitic)	303, 304, 316, 15-5, 17-4	250-450							May not be required at high speeds
K	15 thru 16	Gray Cast Iron	CLS. 20, 30, 45	300-600	.003-.006	1	2				NO
	17 thru 20	Nodular Cast Iron	60-40-18, 100-70-03	300-500							
N	21 thru 30	Aluminum	7075, 6061	800-1500	.003-.007	1					YES
S	31 thru 35	High-Temp Alloys	Inconel, Hastelloy, Nimonic, Monel	50-120	.003-.005		2	3	1		YES
	36 thru 37	Titanium Alloys	6AL-4V, 5Al-5Mo-5V-3Cr	60-130							

Note: Feed and speed recommendations are starting operating parameters. They are only guidelines from which further optimization should take place. Operating parameters are influenced by many machining variables. These variables may cause for reductions in feeds and speed or dramatic increases. Additionally, DOC and WOC may need to be revised to optimize the tools performance.

HIPOST™ OPERATING GUIDELINES - SERIES 12J1G, 12L1G, 2J1G & 2L1G

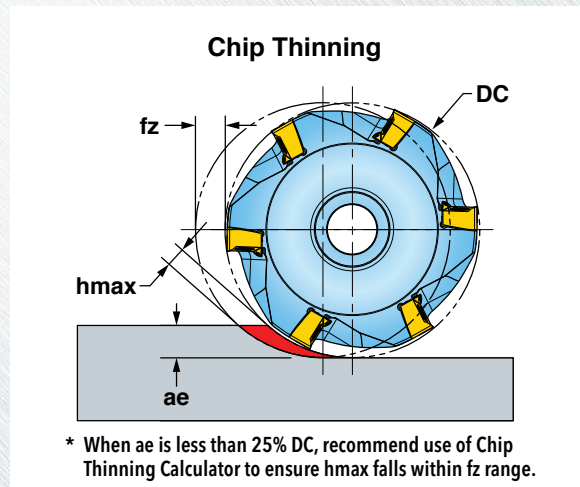

ISO	Materials			V _c Cutting Speed SFM	f _z Feed/ Tooth (inch)	Harder <-----> Tougher										Coolant		
	Mat'l Group #VDI 3323	Type	Examples			IN90D	IN2504	IN2540	IN10K	IN2510	IN2505	IN2005	IN4030	IN2530	IN1030		IN7035	IN2035
P	1 thru 5	Non-alloy Steel	1018, A36, 1045, A572, 1070	400-1000	.003-.008													NO
	6 thru 9	Low-alloy Steel	4140, 4340, P20, 8620, 300M	350-700		5	4				3	2				1		
	10, 11	High-alloy Steel	H13, A2, D2, M2, T1	300-600														
M	12 thru 13	Stainless Steel (Ferritic & Martensitic)	410, 416, 440	350-600	.003-.007													YES
	14	Stainless Steel (Austenitic)	303, 304, 316, 15-5, 17-4	300-550			4				3	2				1		May not be required at high speeds
K	15 thru 16	Gray Cast Iron	CLS. 20, 30, 45	500-1000	.003-.008													NO
	17 thru 20	Nodular Cast Iron	60-40-18, 100-70-03	400-800			2			1	3							
N	21 thru 30	Aluminum	7075, 6061	1000-3000	.003-.009	1			1									YES
S	31 thru 35	High-Temp Alloys	Inconel, Hastelloy, Nimonic, Monel	65-150	.003-.006						2	3			1			YES
	36 thru 37	Titanium Alloys	6AL-4V, 5AL-5Mo-5V-3Cr	85-200							3	2				1		
H	38 thru 39	Hardened Steel >48	A2, 01, D2	130-250	.003-.004		1				2							NO

Note: Feed and speed recommendations are starting operating parameters. They are only guidelines from which further optimization should take place. Operating parameters are influenced by many machining variables. These variables may cause for reductions in feeds and speed or dramatic increases. Additionally, DOC and WOC may need to be revised to optimize the tools performance.



HIPOST™ OPERATING GUIDELINES - SERIES 22J3G & 22J5G

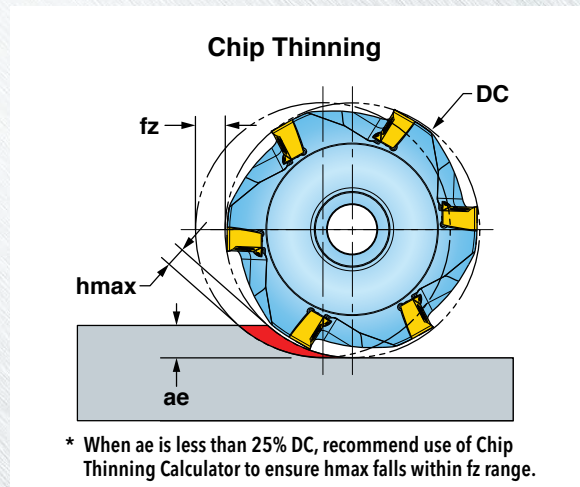

ISO	Materials			V _c Cutting Speed SFM	f _z Feed/Tooth (inch)	Harder <-----> Tougher							Coolant
	Mat'l Group #VDI 3323	Type	Examples			IN2540	IN10K	IN2510	IN2505 IN2005	IN4030 IN2530 IN1030	IN7035 IN2035	IN6537	
P	1 thru 5	Non-alloy Steel	1018, A36, 1045, A572, 1070	300-600	.003-.006	4			3	2	1	NO	
	6 thru 9	Low-alloy Steel	4140, 4340, P20, 8620, 300M	250-500									
	10, 11	High-alloy Steel	H13, A2, D2, M2, T1	250-450									
M	12 thru 13	Stainless Steel (Ferritic & Martensitic)	410, 416, 440	300-500	.003-.005	4			3	2	1	YES	
	14	Stainless Steel (Austenitic)	303, 304, 316, 15-5, 17-4	250-450								May not be required at high speeds	
K	15 thru 16	Gray Cast Iron	CLS. 20, 30, 45	300-600	.003-.006			1	2			NO	
	17 thru 20	Nodular Cast Iron	60-40-18, 100-70-03	300-500									
N	21 thru 30	Aluminum	7075, 6061	800-1500	.003-.007	1						YES	
S	31 thru 35	High-Temp Alloys	Inconel, Hastelloy, Nimonic, Monel	50-120	.003-.005				2	3	1	YES	
	36 thru 37	Titanium Alloys	6AL-4V, 5Al-5Mo-5V-3Cr	60-130					3	2	1		

Note: Feed and speed recommendations are starting operating parameters. They are only guidelines from which further optimization should take place. Operating parameters are influenced by many machining variables. These variables may cause for reductions in feeds and speed or dramatic increases. Additionally, DOC and WOC may need to be revised to optimize the tools performance.

HIPOST™ RAMPING DATA: SERIES 12J1P, 2J1P & 22J3P

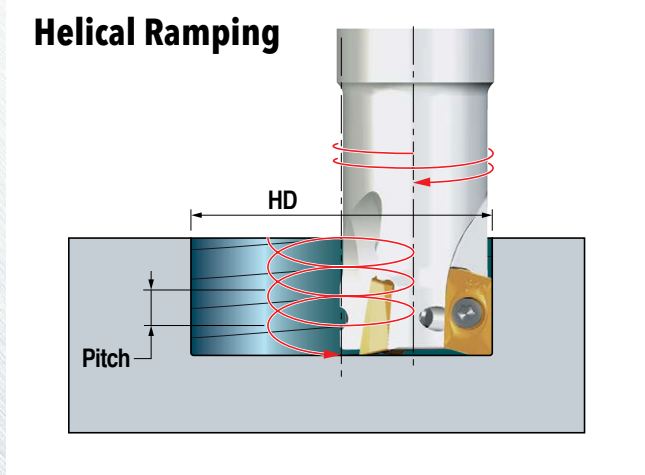
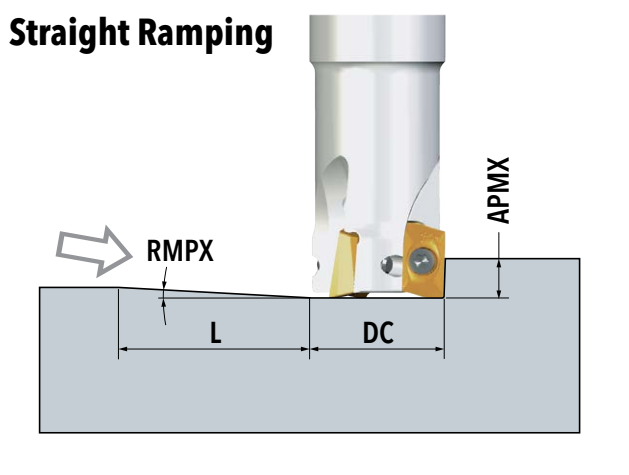

DC Cutter Diameter	Straight Ramp			Helical Ramp		
	RMPX Ramp Angle Max.	APMX Depth of Cut Max.	L Ramp Length Max.	HD Hole Dia. Min.	HD Hole Dia. Max.	Pitch Max.
0.500	10.0	0.35	1.9	0.62		0.080
					0.96	0.230
0.625	10.0	0.35	1.9	0.78		0.080
					1.21	0.330
0.750	7.0	0.35	2.8	1.02		0.110
					1.46	0.280
0.875	5.5	0.35	3.6	1.27		0.110
					1.71	0.240
1.000	4.4	0.35	4.5	1.52		0.110
					1.96	0.220
1.250	2.8	0.35	7.1	2.02		0.110
					2.46	0.180
1.500	2.4	0.35	8.3	2.52		0.140
					2.96	0.200
2.000	1.3	0.35	15.4	3.52		0.100
					3.96	0.130
2.500	1.0	0.35	20.0	4.52		0.100
					4.96	0.120
3.000	0.7	0.35	28.6	5.52		0.100
					5.96	0.100

HIPOST™ RAMPING DATA: SERIES 12J1R, 2J1R & 22J3R

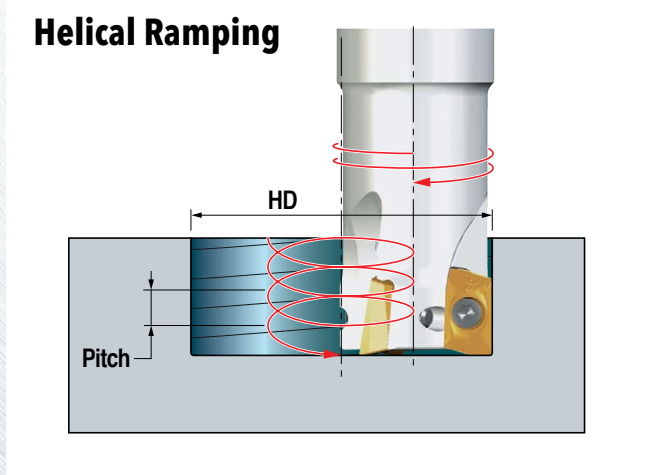
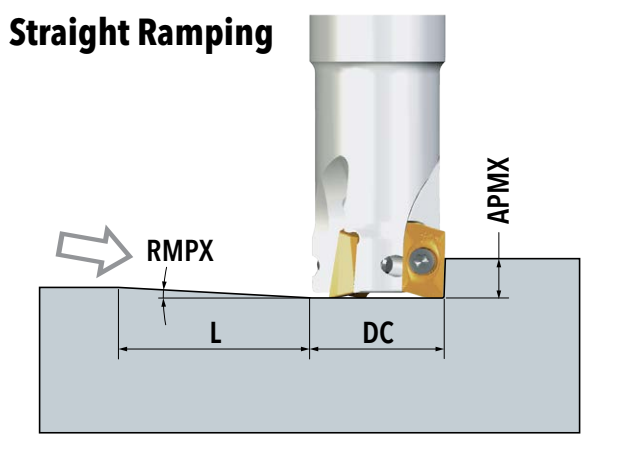

DC Cutter Diameter	Straight Ramp			Helical Ramp		
	RMPX Ramp Angle Max.	APMX Depth of Cut Max.	L Ramp Length Max.	HD Hole Dia. Min.	HD Hole Dia. Max.	Pitch Max.
0.750	7.0	0.47	3.8	1.01		0.090
					1.46	0.280
1.000	7.9	0.47	3.3	1.41		0.200
					1.96	0.400
1.250	5.0	0.47	5.3	1.91		0.180
					2.46	0.330
1.500	3.2	0.47	8.4	2.41		0.160
					2.96	0.260
2.000	2.1	0.47	12.8	3.41		0.160
					3.96	0.220
2.500	1.4	0.47	19.2	4.41		0.140
					4.96	0.180
3.000	1.0	0.47	26.9	5.41		0.130
					5.96	0.160
4.000	0.8	0.47	33.7	7.41		0.140
					7.96	0.160
5.000	0.6	0.47	44.9	9.41		0.140
					9.96	0.150

HIPOST™ RAMPING DATA: SERIES 12J1G, 2J1G & 22J3G

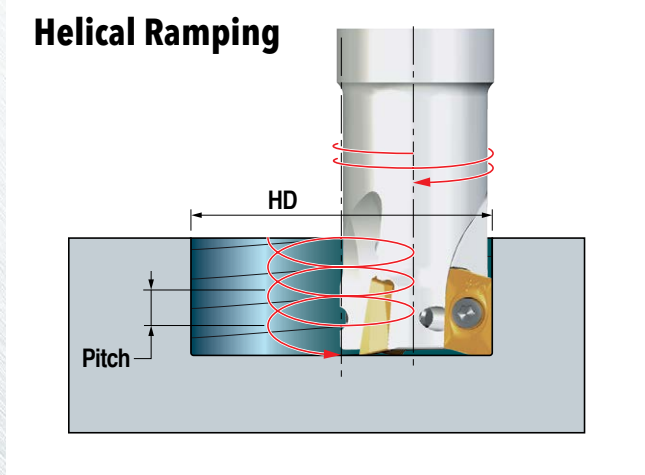
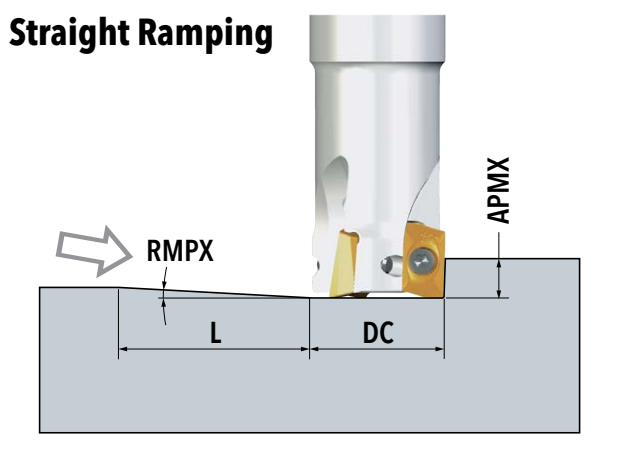

DC Cutter Diameter	Straight Ramp			Helical Ramp		
	RMPX Ramp Angle Max.	APMX Depth of Cut Max.	L Ramp Length Max.	HD Hole Dia. Min.	HD Hole Dia. Max.	Pitch Max.
0.750	8.0	0.63	4.5	0.85		0.020
					1.50	0.280
1.000	5.0	0.63	7.2	1.24		0.050
					2.00	0.200
1.250	9.0	0.63	4.0	1.74		0.200
					2.50	0.500
1.500	5.0	0.63	7.2	2.24		0.180
					3.00	0.350
2.000	4.0	0.63	8.2	3.24		0.240
					4.00	0.400
2.500	3.0	0.63	11.2	4.24		0.250
					5.00	0.300
3.000	2.0	0.63	15.7	5.24		0.260
					6.00	0.300
4.000	1.8	0.63	20.0	7.24		0.260
					8.00	0.300
5.000	1.4	0.63	26.0	9.24		0.270
					10.00	0.300
6.000	1.0	0.63	36.0	11.24		0.250
					12.00	0.280
8.000	0.5	0.63	52.0	15.24		0.230
					16.00	0.250