

HIPOST[™] RAMPING DATA: SERIES 12J1R, 2J1R & 22J3R

Straight Ramping

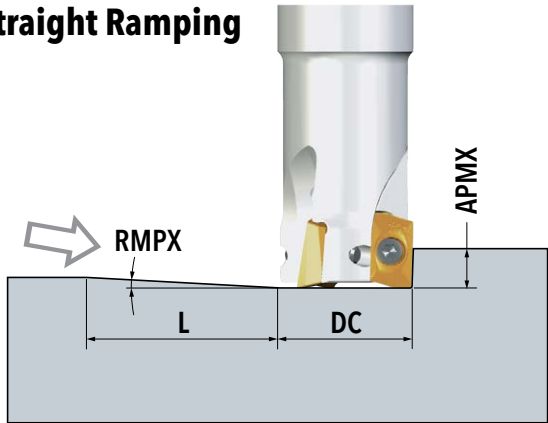

Helical Ramping

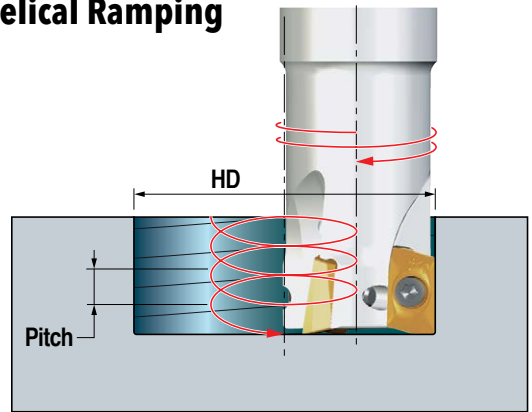

DC Cutter Diameter	Straight Ramp			Helical Ramp		
	RMPX Ramp Angle Max.	APMX Depth of Cut Max.	L Ramp Length Max.	HD Hole Dia. Min.	HD Hole Dia. Max.	Pitch Max.
0.750	7.0	0.47	3.8	1.01	1.46	0.090 0.280
1.000	7.9	0.47	3.3	1.41	1.96	0.200 0.400
1.250	5.0	0.47	5.3	1.91	2.46	0.180 0.330
1.500	3.2	0.47	8.4	2.41	2.96	0.160 0.260
2.000	2.1	0.47	12.8	3.41	3.96	0.160 0.220
2.500	1.4	0.47	19.2	4.41	4.96	0.140 0.180
3.000	1.0	0.47	26.9	5.41	5.96	0.130 0.160
4.000	0.8	0.47	33.7	7.41	7.96	0.140 0.160
5.000	0.6	0.47	44.9	9.41	9.96	0.140 0.150