

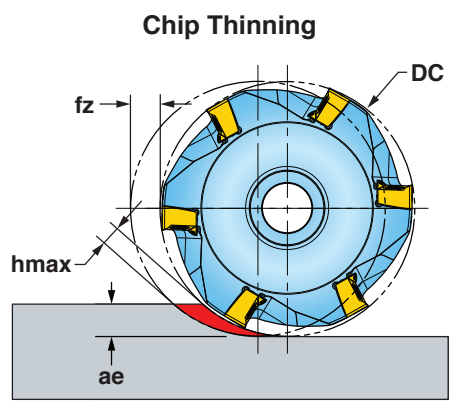

**HIPOST™ OPERATING GUIDELINES: SERIES 22J3P**



\* When ae is less than 25% DC, recommend use of Chip Thinning Calculator to ensure hmax falls within fz range.

ISO	Mat'l Group #VDI 3323	Materials		V <sub>c</sub> Cutting Speed SFM	f <sub>z</sub> Feed/Tooth (inch)	Harder <-----> Tougher								Coolant
		Type	Examples			IN2504	IN10K	IN2010	IN2505	IN4030 IN2530	IN2035	IN2036	IN6537	
P	1 thru 5	Non-alloy Steel	1018, A36, 1045, A572, 1070	300-600	.003-.005	4			3	2	1	NO		
	6 thru 9	Low-alloy Steel	4140, 4340, P20, 8620, 300M	250-500										
	10, 11	High-alloy Steel	H13, A2, D2, M2, T1	250-450										
M	12 thru 13	Stainless Steel (Ferritic & Martensitic)	410, 416, 440	300-500	.003-.004			4	3	2	1	YES		
	14			Stainless Steel (Austenitic)								303, 304, 316, 15-5, 17-4	250-450	May not be required at high speeds
K	15 thru 16	Gray Cast Iron	CLS. 20, 30, 45	300-600	.003-.005	1		2	4			3	NO	
	17 thru 20	Nodular Cast Iron	60-40-18, 100-70-03	300-500										
N	21 thru 30	Aluminum	7075, 6061	800-1500	.003-.006		1					YES		
S	31 thru 35	High-Temp Alloys	Inconel, Hastelloy, Nimonic, Monel	50-120	.003-.004				3	4	2	1	YES	
	36 thru 37	Titanium Alloys	6AL-4V, 5AL-5Mo-5V-3Cr	60-130										4

Note: Feed and speed recommendations are starting operating parameters. They are only guidelines from which further optimization should take place. Operating parameters are influenced by many machining variables. These variables may cause for reductions in feeds and speed or dramatic increases. Additionally, DOC and WOC may need to be revised to optimize the tools performance.

**HIPOST™ CUTTER BODY MODIFICATION FOR LARGE RADIUS INSERTS**

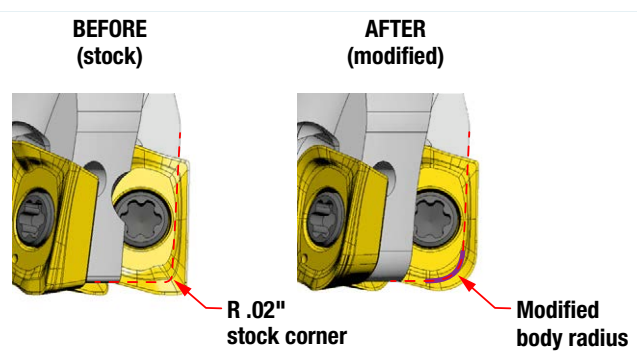

Insert Size	Modify Cutter Body If Insert Radius Exceeds	Insert Radius	Modified Body Radius
9mm	.062"	0.078	0.050
		0.120	0.100

When using an insert radius larger than indicated per Insert IC, be sure the cutter body does not protrude beyond the trailing edge of the insert. If it does, the housing corner can be modified on a lathe or grinder by enlarging the corner radius.