

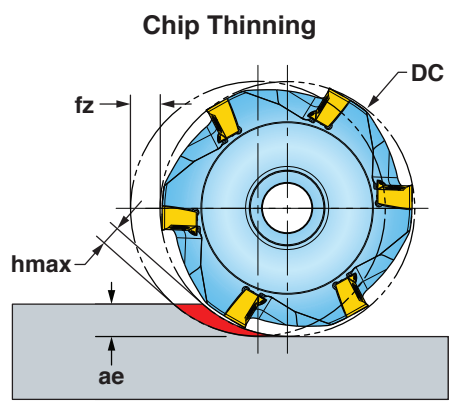

**OPERATING GUIDELINES:  
SERIES 12J1G, 12L1G,  
12N1G, 2J1G & 2L1G**



\* When ae is less than 25% DC, recommend use of Chip Thinning Calculator to ensure hmax falls within fz range.

ISO	Mat'l Group #VDI 3323	Materials		V <sub>c</sub> Cutting Speed SFM	f <sub>z</sub> Feed/Tooth (inch)	Harder <-----> Tougher											Coolant		
		Type	Examples			IN90D	IN2504	IN2540	IN10K	IN2510	IN2505	IN2005	IN4030	IN2530	IN1030	IN7035		IN2035	IN2036
P	1 thru 5	Non-alloy Steel	1018, A36, 1045, A572, 1070	400-1000	.003-.008														NO
	6 thru 9	Low-alloy Steel	4140, 4340, P20, 8620, 300M	350-700		5	4				3	2					1		
	10, 11	High-alloy Steel	H13, A2, D2, M2, T1	300-600															
M	12 thru 13	Stainless Steel (Ferritic & Martensitic)	410, 416, 440	350-600	.003-.007													YES May not be required at high speeds	
	14			Stainless Steel (Austenitic)		303, 304, 316, 15-5, 17-4	300-550		5			4	3	2	1				
K	15 thru 16	Gray Cast Iron	CLS. 20, 30, 45	500-1000	.003-.008													NO	
	17 thru 20	Nodular Cast Iron	60-40-18, 100-70-03	400-800		2			1	3									
N	21 thru 30	Aluminum	7075, 6061	1000-3000	.003-.009	1			1									YES	
S	31 thru 35	High-Temp Alloys	Inconel, Hastelloy, Nimonic, Monel	65-150	.003-.006							3	4	2	1			YES	
	36 thru 37	Titanium Alloys	6AL-4V, 5Al-5Mo-5V-3Cr	85-200							4	3	2	1					
H	38 thru 39	Hardened Steel >48	A2, 01, D2	130-250	.003-.004		1				2							NO	

Note: Feed and speed recommendations are starting operating parameters. They are only guidelines from which further optimization should take place. Operating parameters are influenced by many machining variables. These variables may cause for reductions in feeds and speed or dramatic increases. Additionally, DOC and WOC may need to be revised to optimize the tools performance.



**CUTTER BODY MODIFICATION FOR LARGE RADIUS INSERTS**

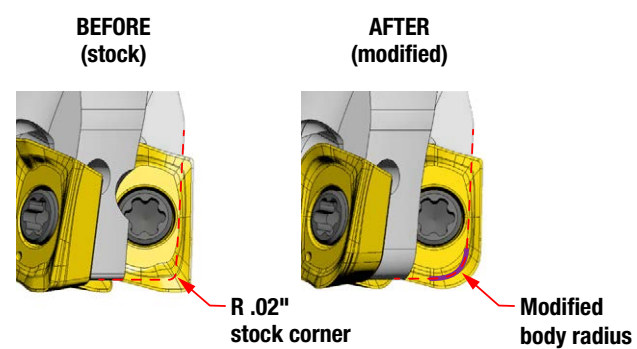

Insert Size	Modify Cutter Body If Insert Radius Exceeds	Insert Radius	Modified Body Radius
17mm	.093"	0.125	0.110
		0.156	0.110
		0.187	0.110
		0.250	0.200

When using an insert radius larger than indicated per Insert IC, be sure the cutter body does not protrude beyond the trailing edge of the insert. If it does, the housing corner can be modified on a lathe or grinder by enlarging the corner radius.