

HIPOST[™] RAMPING DATA: SERIES 12J1P, 2J1P & 22J3P

Straight Ramping

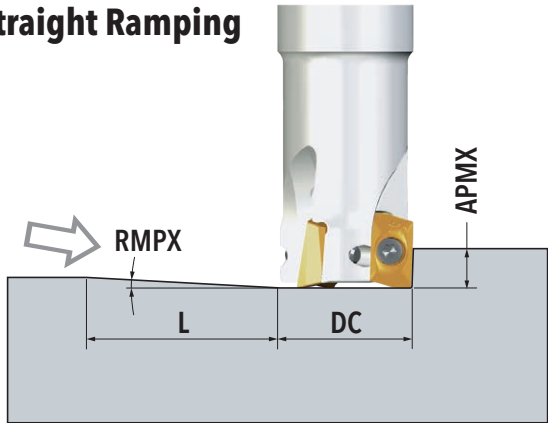

Helical Ramping

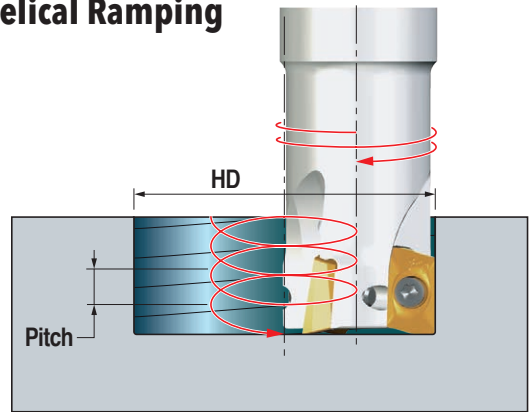

| DC Cutter Diameter | Straight Ramp | | | Helical Ramp | | |
|--------------------------|-------------------------|---------------------------|-----------------------|----------------------|----------------------|------------|
| | RMPX Ramp Angle Max. | APMX Depth of Cut Max. | L Ramp Length Max. | HD Hole Dia. Min. | HD Hole Dia. Max. | Pitch Max. |
| 0.500 | 10.0 | 0.35 | 1.9 | 0.62 | | 0.080 |
| | | | | | 0.96 | 0.230 |
| 0.625 | 10.0 | 0.35 | 1.9 | 0.78 | | 0.080 |
| | | | | | 1.21 | 0.330 |
| 0.750 | 7.0 | 0.35 | 2.8 | 1.02 | | 0.110 |
| | | | | | 1.46 | 0.280 |
| 0.875 | 5.5 | 0.35 | 3.6 | 1.27 | | 0.110 |
| | | | | | 1.71 | 0.240 |
| 1.000 | 4.4 | 0.35 | 4.5 | 1.52 | | 0.110 |
| | | | | | 1.96 | 0.220 |
| 1.250 | 2.8 | 0.35 | 7.1 | 2.02 | | 0.110 |
| | | | | | 2.46 | 0.180 |
| 1.500 | 2.4 | 0.35 | 8.3 | 2.52 | | 0.140 |
| | | | | | 2.96 | 0.200 |
| 2.000 | 1.3 | 0.35 | 15.4 | 3.52 | | 0.100 |
| | | | | | 3.96 | 0.130 |
| 2.500 | 1.0 | 0.35 | 20.0 | 4.52 | | 0.100 |
| | | | | | 4.96 | 0.120 |
| 3.000 | 0.7 | 0.35 | 28.6 | 5.52 | | 0.100 |
| | | | | | 5.96 | 0.100 |