

HIPOST™ OPERATING GUIDELINES: SERIES 22J3R

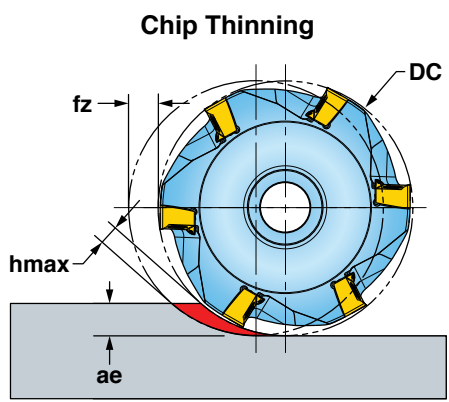

* When ae is less than 25% DC, recommend use of Chip Thinning Calculator to ensure hmax falls within fz range.

ISO	Materials			V _c Cutting Speed SFM	f _z Feed/Tooth (inch)	Harder <-----> Tougher										Coolant
	Mat'l Group #VDI 3323	Type	Examples			PCD	Cermets		Carbide							
							IN90D	IN0560	IN2504	IN10K	IN2010	IN2540	IN2505	IN2005	IN4030	
P	1 thru 5	Non-alloy Steel	1018, A36, 1045, A572, 1070	300-600	.003-.006						4	2	1	3	NO	
				450-900		1										
	6 thru 9	Low-alloy Steel	4140, 4340, P20, 8620, 300M	250-500							4	2	1	3		
				350-700		1										
10, 11	High-alloy Steel	H13, A2, D2, M2, T1	250-450						4	2	1	3				
			350-650	1												
M	12 thru 13	Stainless Steel (Ferritic & Martensitic)	410, 416, 440	300-500	.003-.005										YES May not be required at high speeds	
	14			250-450							3	2	1			
K	15 thru 16	Gray Cast Iron	CLS. 20, 30, 45	300-600	.003-.006										NO	
	17 thru 20			Nodular Cast Iron		300-500			2	1	3			4		
N	21 thru 30	Aluminum	7075, 6061	800-1500	.003-.007	1			1						YES	
S	31 thru 35	High-Temp Alloys	Inconel, Hastelloy, Nimonic, Monel	50-120	.003-.005							2	3	1	YES	
	36 thru 37			Titanium Alloys		60-130						3	2	1		

Note: Feed and speed recommendations are starting operating parameters. They are only guidelines from which further optimization should take place. Operating parameters are influenced by many machining variables. These variables may cause for reductions in feeds and speed or dramatic increases. Additionally, DOC and WOC may need to be revised to optimize the tools performance.