

HIPOSTRIO™ 10 RAMP DATA USING SERIES TH_S10

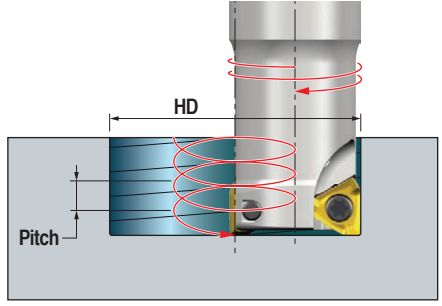
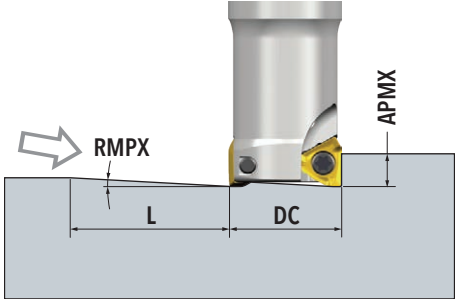

DC Cutter Diameter	Straight Ramp			Helical Ramp		
	RMPX Ramp Angle Max.	APMX Depth of Cut Max.	L Ramp Length Min.	HD Hole Diameter Min.	HD Hole Diameter Max.	Pitch Max.
1.250	2.7	0.41	8.6	2.04	2.50	0.120
						0.180
1.500	1.7	0.41	13.8	2.57	3.00	0.100
						0.130
2.000	1.2	0.41	19.5	3.58	4.00	0.100
						0.120
2.500	1.0	0.41	23.4	4.57	5.00	0.110
						0.120
3.000	0.7	0.41	33.5	5.57	6.00	0.110
						0.120
4.000	0.6	0.41	39.1	7.57	8.00	0.110
						0.120
5.000	0.4	0.41	58.7	9.57	10.00	0.110
						0.110