



TURNING

Insert Styles

CCGT 21.5/32.5
DCGT 21.5/32.5
VBGT 22
VCGT 22

Corner Radii

.004", .008", .016"



Chip Breakers

SL - Low DOC & Feed
SM - First Choice
SH - Large DOC, Stronger Edge
NEW ST - Maximum DOC for one-pass machining

Grades

TT4410
PVD coated for maximum wear resistance
TT4430
PVD coated for general purpose machining; First choice
TT9020
PVD coated for maximum toughness

Materials

 Steel
 Stainless Steel
 Super Alloys

MINITURN™

Turning Grades and Chip Breakers for Swiss Type Lathes and Finish Bore Applications

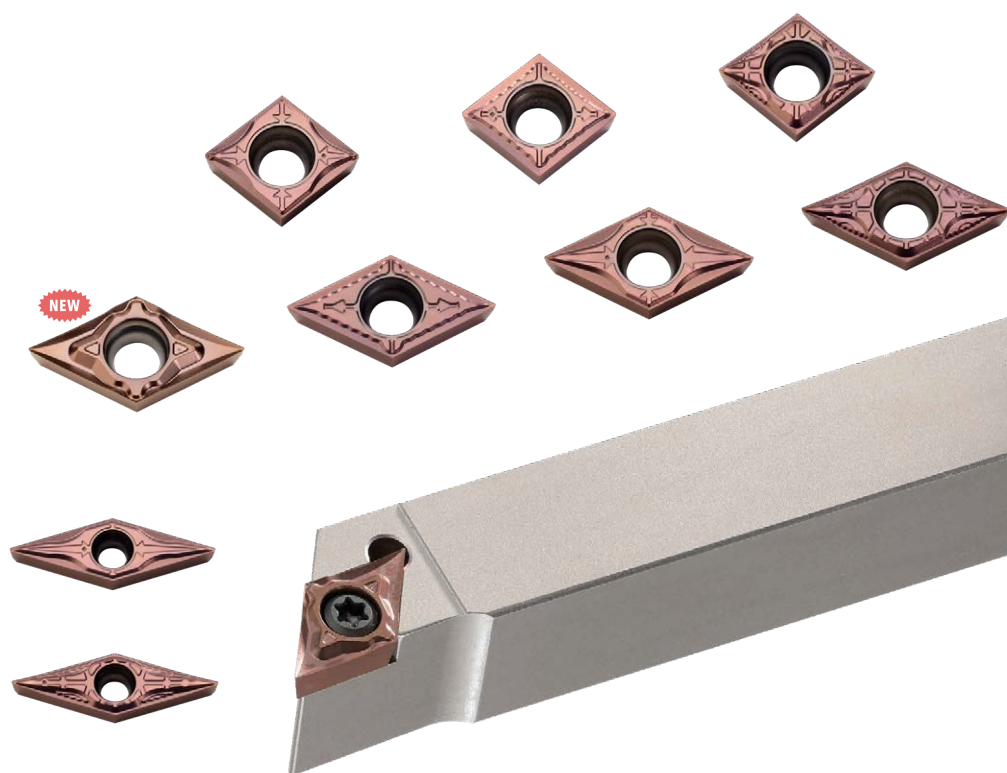

Features & Benefits

- » Two grades reduce peeling, flaking & chipping while offering longer tool life than existing grades.
- » Four chip breakers dramatically expand our comprehensive program of precision inserts and provide options to control chips in virtually any application
- » Accurate "G" tolerance inserts provide high precision and excellent surface finish
- » Inserts are also ideal for precision boring applications
- » Neutral designed inserts offer a single solution for either right or left-handed tools

For more information »



Features

When machining small components using Swiss type lathes, long tool life, good chip control and excellent surface finish are required under generally low machining conditions. Furthermore, when machining a variety of workpiece materials it's often beneficial and more efficient to use insert grades that have wide application ranges in order to reduce tool changes. In line with these demands, Ingersoll has developed two new PVD-coated grades along with three new chip breakers that can be applied to a wide variety of materials and cutting conditions.

New grades TT4410 and TT4430 offer more wear resistance, long tool life, and excellent surface finish and dimensional precision in a variety of materials typically used for small component machining, particularly under low cutting speeds and feeds. The superfine substrate is combined with a PVD-ALTiCrN coating with excellent adhesion to the precision ground surface of the insert, resulting in less peeling and chipping and more consistent tool life. This coating also resists workpiece build up on the insert.

The SL chip breaker is intended for super-finishing applications. It excels at breaking chips and providing accurate results at very light cutting depths, from .001" to .010". By minimizing chip control problems during machining, a more uniform and accurate workpiece surface finish is achieved.

The general-purpose and first-choice SM chip breaker produces very low cutting forces due to the high positive rake face geometry. The chip control is outstanding over a wide range of cutting depths up to .060". It, too, ensures very good surface finish and dimensional precision.

The SH chip breaker has a wider groove width that is particularly suitable for processing automotive parts. This stronger geometry still generates relatively low cutting forces and produces very good machining results at higher cutting depths, up to .138".

The ST chip breaker features a high rake angle design that provides stable tool life due to the low cutting force generated during machining. This new chip breaker allows for deep depth of cut machining, up to .197". This lowers the number of passes required, resulting in increased productivity. In addition, the cutting-edge design is ideal for the oscillation/vibration cutting feature popular in Swiss style machines.

All inserts within this new series include a suffix at the end of the part description. The "-F" designation indicates the presence of a sharp edge for the lowest possible cutting forces and excellent surface finish, while the "-E" designation indicates a micro-honed edge that prevents chipping in more demanding or unstable applications.

Grades

TT4410

- High wear resistant micro-alloy substrate with excellent ground surface
- Multi AlTiCrN coating layer with improved bonding on substrate and anti-adhesion of workpiece material
- Suitable for steel, stainless steel, heat-resistant super alloy and Ti-alloy in high-speed continuous cutting
- Suitable for hardened steel in low-speed continuous cutting
- Dark brown color

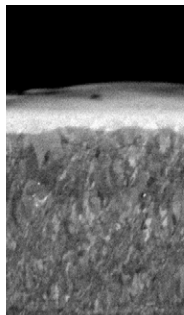

TT4430

- Toughened micro-alloy substrate
- Multi AlTiCrN coating layer with stabilized edge, anti-adhesion of workpiece material and high chipping resistance
- Suitable for steel, stainless steel, heat-resistant super alloy and Ti-alloy. Ideal for low-medium speed continuous cutting and light interrupted cutting
- Dark brown color

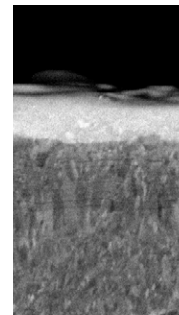

Application Range

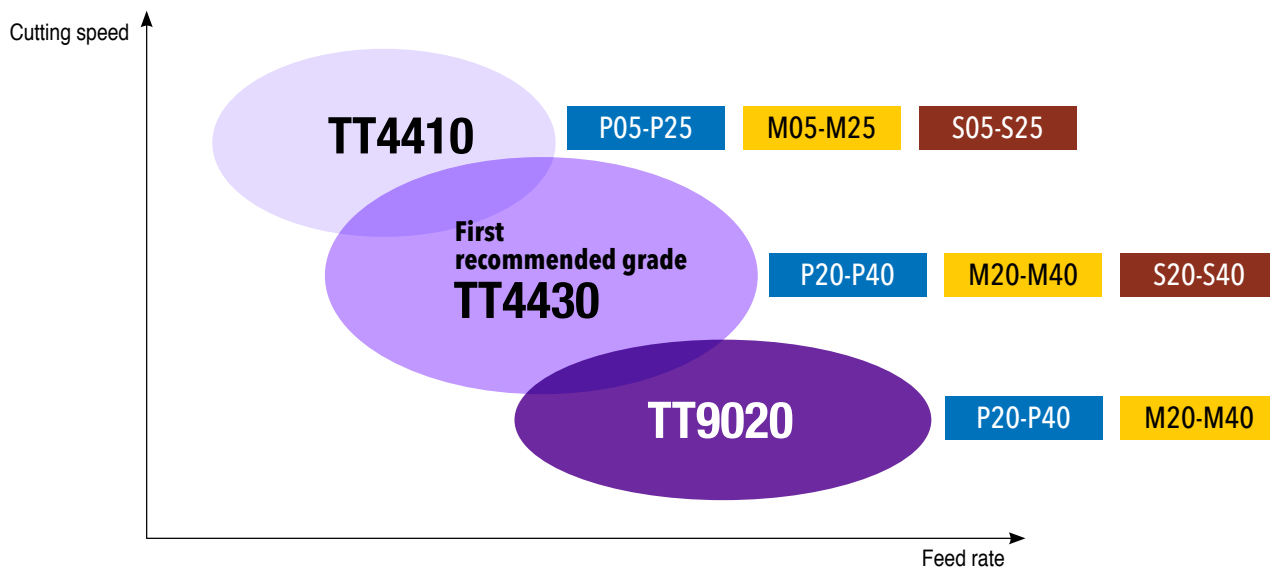

SL Chip Breaker

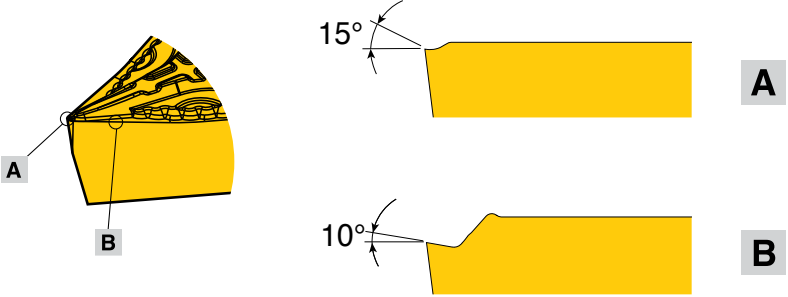
Chip breaker	Edge geometry
 <p style="text-align: center;">SL</p>	

- High performance in low depth of cut and low feed machining
- Excellent chip control due to wave geometry edge and special inclined design
- Recommended depth of cut: .001"-.010"

SM Chip Breaker

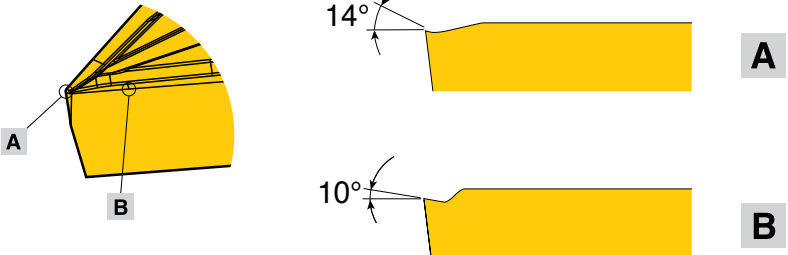
Chip breaker	Edge geometry
 <p style="text-align: center;">SM</p>	

- 1st recommended chip breaker for Swiss type automatic lathes
- Stable cutting edge and low cutting force
- Long tool life and good surface finish
- Recommended depth of cut: .008"-.059"

SH Chip Breaker

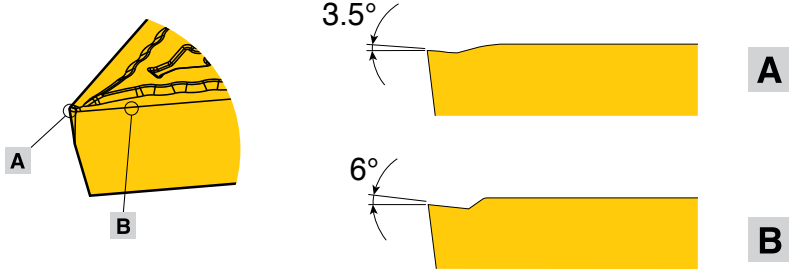
Chip breaker	Edge geometry
 <p>SH</p>	

- Suitable for deep depth of cut machining
- Excellent chip control in a wide machining range
- A well balanced cutting edge combining sharpness and strength
- Recommended depth of cut: .027"-.138"

ST Chip Breaker NEW

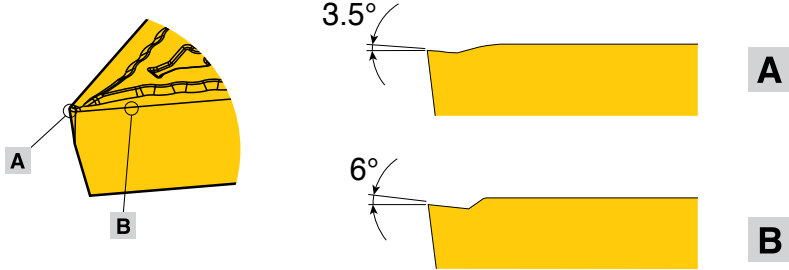
Chip breaker	Edge geometry
 <p>ST</p>	

- For maximum depth of cut machining in Swiss applications
- High rake angle chipbreaker for smooth chip formation
- Unique chipbreaker design pushes continuous chip away from workpiece
- Recommended depth of cut: .012"-.197"

Series CCGT SL

POSITIVE 7° CLEARANCE 80° RHOMBIC INSERTS FOR FINISHING APPLICATIONS

	Size	Dimensions (inch)				
		IC Inscribed Circle	S Thickness	RE Corner Radius	L Edge Length	D1 Hole Dia.
	21.50.5	.250	.094	.008	.254	.110
	32.50	.375	.156	.004	.382	.173
	32.50.5	.375	.156	.008	.382	.173
32.51	.375	.156	.016	.382	.173	

Part Number		ap (inch)		fn (ipr)		PVD Coated	
ANSI	ISO	Depth of Cut		Feed Rate		TT4410	TT4430
		Min.	Max.	Feed Min.	Feed Max.		
INCH							
CCGT21.50.5M-SL-F	CCGT060202M-SL-F	.001	.010	.0008	.0039	●	●
CCGT32.50M-SL-F	CCGT09T301M-SL-F	.001	.010	.0006	.0039	●	●
CCGT32.50.5M-SL-F	CCGT09T302M-SL-F	.001	.010	.0008	.0039	●	●

● = Standard Items

Series CCGT SM

POSITIVE 7° CLEARANCE 80° RHOMBIC INSERTS FOR MEDIUM APPLICATIONS

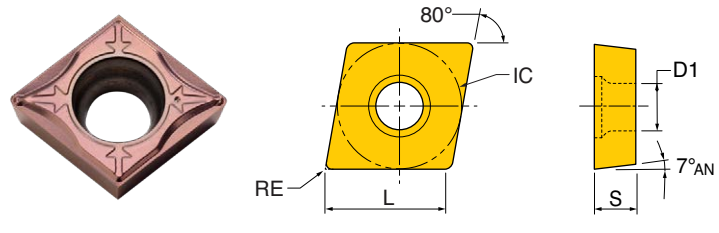
	Size	Dimensions (inch)				
		IC Inscribed Circle	S Thickness	RE Corner Radius	L Edge Length	D1 Hole Dia.
	21.50.5	.250	.094	.008	.254	.110
	32.50	.375	.156	.004	.382	.173
	32.50.5	.375	.156	.008	.382	.173
32.51	.375	.156	.016	.382	.173	

Part Number		ap (inch)		fn (ipr)		PVD Coated	
ANSI	ISO	Depth of Cut		Feed Rate		TT4410	TT4430
		Min.	Max.	Feed Min.	Feed Max.		
INCH							
CCGT21.50.5M-SM-F	CCGT060202M-SM-F	.001	.059	.0008	.0047	●	●
CCGT32.50M-SM-F	CCGT09T301M-SM-F	.001	.059	.0008	.0047	●	●
CCGT32.50.5M-SM-F	CCGT09T302M-SM-F	.001	.059	.0008	.0047	●	●
CCGT32.51M-SM-F	CCGT09T304M-SM-F	.001	.059	.0012	.0047	●	●

● = Standard Items

Series CCGT SH

POSITIVE 7° CLEARANCE 80° RHOMBIC INSERTS FOR ROUGHING APPLICATIONS

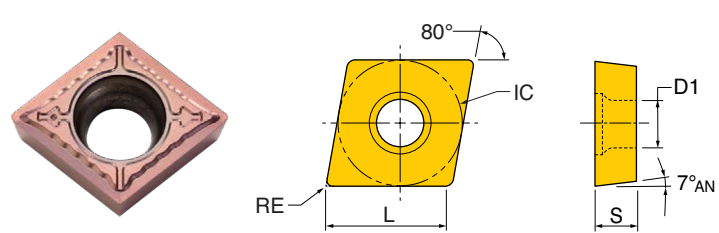
	Size	Dimensions (inch)				
		IC Inscribed Circle	S Thickness	RE Corner Radius	L Edge Length	D1 Hole Dia.
	21.50.5	.250	.094	.008	.254	.110
	32.50	.375	.156	.004	.382	.173
	32.50.5	.375	.156	.008	.382	.173
32.51	.375	.156	.016	.382	.173	

Part Number		ap (inch)		fn (ipr)		PVD Coated	
ANSI	ISO	Depth of Cut		Feed Rate		TT4410	TT4430
		Min.	Max.	Feed Min.	Feed Max.		
INCH							
CCGT32.51M-SH-F	CCGT09T304M-SH-F	.028	.138	.0028	.0067	●	●

● = Standard Items

Series DCGT SL

POSITIVE 7° CLEARANCE 55° RHOMBIC INSERTS FOR FINISHING APPLICATIONS

Size	Dimensions (inch)				
	IC Inscribed Circle	S Thickness	RE Corner Radius	L Edge Length	D1 Hole Dia.
21.50	.250	.094	.004	.303	.110
21.50.5	.250	.094	.008	.303	.110
21.51	.250	.094	.016	.303	.110
32.50	.375	.156	.004	.457	.173
32.50.5	.375	.156	.008	.457	.173
32.51	.375	.156	.016	.457	.173

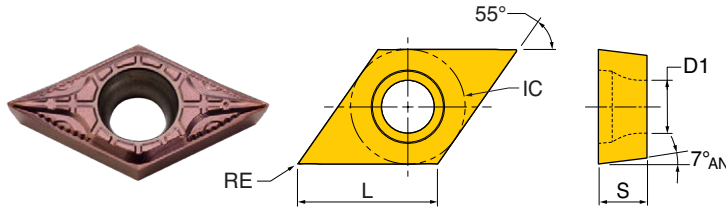

Part Number		ap (inch)		fn (ipr)		PVD Coated	
ANSI	ISO	Depth of Cut		Feed Rate		TT4410	TT4430
		Min.	Max.	Feed Min.	Feed Max.		
INCH							
DCGT21.50M-SL-F	DCGT070201M-SL-F	.001	.010	.0006	.0039	●	●
DCGT21.50.5M-SL-F	DCGT070202M-SL-F	.001	.010	.0008	.0039	●	●
DCGT32.50M-SL-F	DCGT11T301M-SL-F	.001	.010	.0006	.0039	●	●
DCGT32.50.5M-SL-F	DCGT11T302M-SL-F	.001	.010	.0008	.0039	●	●

● = Standard Items

Series DCGT SM

POSITIVE 7° CLEARANCE 55° RHOMBIC INSERTS FOR MEDIUM APPLICATIONS

Size	Dimensions (inch)				
	IC Inscribed Circle	S Thickness	RE Corner Radius	L Edge Length	D1 Hole Dia.
21.50	.250	.094	.004	.303	.110
21.50.5	.250	.094	.008	.303	.110
21.51	.250	.094	.016	.303	.110
32.50	.375	.156	.004	.457	.173
32.50.5	.375	.156	.008	.457	.173
32.51	.375	.156	.016	.457	.173

Part Number		ap (inch)		fn (ipr)		PVD Coated	
ANSI	ISO	Depth of Cut		Feed Rate		TT4410	TT4430
		Min.	Max.	Feed Min.	Feed Max.		
INCH							
DCGT21.50M-SM-F	DCGT070201M-SM-F	.001	.059	.0008	.0047	•	•
DCGT21.50.5M-SM-F	DCGT070202M-SM-F	.001	.059	.0008	.0047	•	•
DCGT21.51M-SM-F	DCGT070204M-SM-F	.001	.059	.0012	.0047	•	•
DCGT32.50M-SM-F	DCGT11T301M-SM-F	.001	.059	.0008	.0047	•	•
DCGT32.50.5M-SM-F	DCGT11T302M-SM-F	.001	.059	.0008	.0047	•	•
DCGT32.51M-SM-F	DCGT11T304M-SM-F	.001	.059	.0012	.0047	•	•

• = Standard Items

Series DCGT SH

POSITIVE 7° CLEARANCE 55° RHOMBIC INSERTS FOR ROUGHING APPLICATIONS

Size	Dimensions (inch)				
	IC Inscribed Circle	S Thickness	RE Corner Radius	L Edge Length	D1 Hole Dia.
21.50	.250	.094	.004	.303	.110
21.50.5	.250	.094	.008	.303	.110
21.51	.250	.094	.016	.303	.110
32.50	.375	.156	.004	.457	.173
32.50.5	.375	.156	.008	.457	.173
32.51	.375	.156	.016	.457	.173

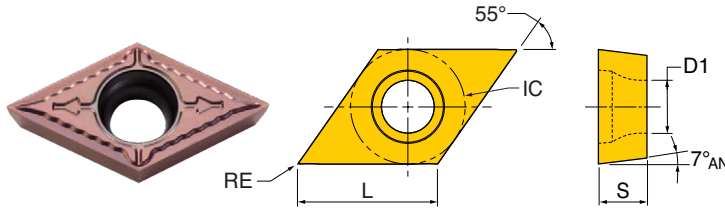

Part Number		ap (inch)		fn (ipr)		PVD Coated	
ANSI	ISO	Depth of Cut		Feed Rate		TT4410	TT4430
		Min.	Max.	Feed Min.	Feed Max.		
INCH							
DCGT32.50.5M-SH-E	DCGT11T302M-SH-E	.028	.138	.0020	.0059		•
DCGT32.50.5M-SH-F	DCGT11T302M-SH-F	.028	.138	.0020	.0059	•	•
DCGT32.51M-SH-F	DCGT11T304M-SH-F	.028	.138	.0028	.0067	•	•

• = Standard Items

Series DCGT ST **NEW**

POSITIVE 7° CLEARANCE 55° RHOMBIC INSERTS FOR ROUGHING APPLICATIONS

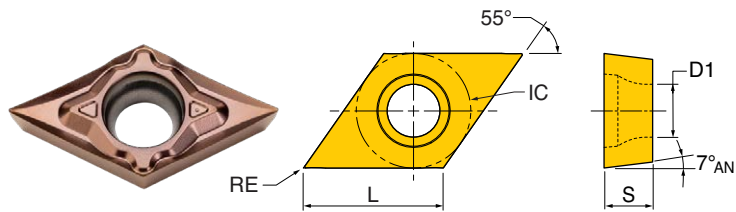

Size	Dimensions (inch)				
	IC Inscribed Circle	S Thickness	RE Corner Radius	L Edge Length	D1 Hole Dia.
21.50	.250	.094	.004	.303	.110
21.50.5	.250	.094	.008	.303	.110
21.51	.250	.094	.016	.303	.110
32.50	.375	.156	.004	.457	.173
32.50.5	.375	.156	.008	.457	.173
32.51	.375	.156	.016	.457	.173

Part Number		ap (inch)		fn (ipr)		PVD Coated	
ANSI	ISO	Depth of Cut		Feed Rate		TT430	TT920
		Min.	Max.	Feed Min.	Feed Max.		
INCH							
DCGT32.50M-ST-E	DCGT11T301M-ST-E	.012	.197	.0012	.0031	•	
DCGT32.50M-ST-F	DCGT11T301M-ST-F	.012	.197	.0012	.0031	•	•
DCGT32.50.5M-ST-E	DCGT11T302M-ST-E	.020	.197	.0012	.0039	•	
DCGT32.50.5M-ST-F	DCGT11T302M-ST-F	.020	.197	.0012	.0039	•	•
DCGT32.51M-ST-E	DCGT11T304M-ST-E	.028	.197	.0020	.0047	•	
DCGT32.51M-ST-F	DCGT11T304M-ST-F	.028	.197	.0020	.0047	•	•

• = Standard Items

Series VBGT SL

POSITIVE 5° CLEARANCE 35° RHOMBIC INSERTS FOR FINISHING APPLICATIONS

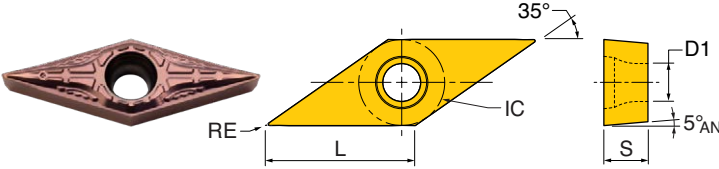
	Size	Dimensions (inch)				
		IC Inscribed Circle	S Thickness	RE Corner Radius	L Edge Length	D1 Hole Dia.
	220	.250	.125	.004	.437	.110
	220.5	.250	.125	.008	.437	.110
221	.250	.125	.016	.437	.110	

Part Number		ap (inch)		fn (ipr)		PVD Coated	
ANSI	ISO	Depth of Cut		Feed Rate		TT4410	TT4430
		Min.	Max.	Feed Min.	Feed Max.		
INCH							
VBGT220.5M-SL-F	VBGT110302M-SL-F	.001	.010	.0008	.0039	•	•

• = Standard Items

Series VBGT SM

POSITIVE 5° CLEARANCE 35° RHOMBIC INSERTS FOR MEDIUM APPLICATIONS

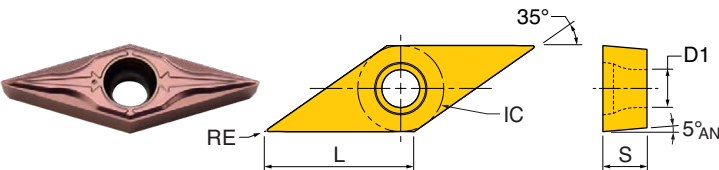
	Size	Dimensions (inch)				
		IC Inscribed Circle	S Thickness	RE Corner Radius	L Edge Length	D1 Hole Dia.
	220	.250	.125	.004	.437	.110
	220.5	.250	.125	.008	.437	.110
221	.250	.125	.016	.437	.110	

Part Number		ap (inch)		fn (ipr)		PVD Coated	
ANSI	ISO	Depth of Cut		Feed Rate		TT4410	TT4430
		Min.	Max.	Feed Min.	Feed Max.		
INCH							
VBGT220M-SM-F	VBGT110301M-SM-F	.001	.059	.0008	.0047	•	•
VBGT220.5M-SM-F	VBGT110302M-SM-F	.001	.059	.0008	.0047	•	•
VBGT221M-SM-F	VBGT110304M-SM-F	.001	.059	.0012	.0047	•	•

• = Standard Items

Series VCGT SL

POSITIVE 5° CLEARANCE 35° RHOMBIC INSERTS FOR FINISHING APPLICATIONS

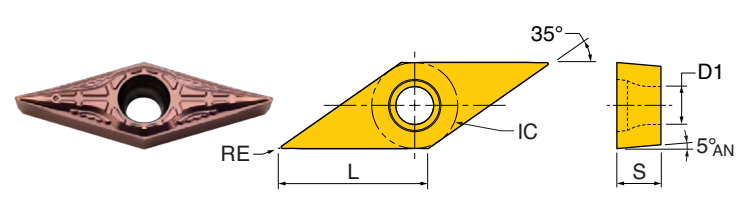

Size	Dimensions (inch)				
	IC Incribed Circle	S Thickness	RE Corner Radius	L Edge Length	D1 Hole Dia.
220	.250	.125	.004	.437	.110
220.5	.250	.125	.008	.437	.110
221	.250	.125	.016	.437	.110

Part Number		ap (inch)		fn (ipr)		PVD Coated	
ANSI	ISO	Depth of Cut		Feed Rate		TT4410	TT4430
		Min.	Max.	Feed Min.	Feed Max.		
INCH							
VCGT220.5M-SL-F	VCGT110302M-SL-F	.001	.010	.0008	.0039	•	•

• = Standard Items

Series VCGT SM

POSITIVE 5° CLEARANCE 35° RHOMBIC INSERTS FOR MEDIUM APPLICATIONS

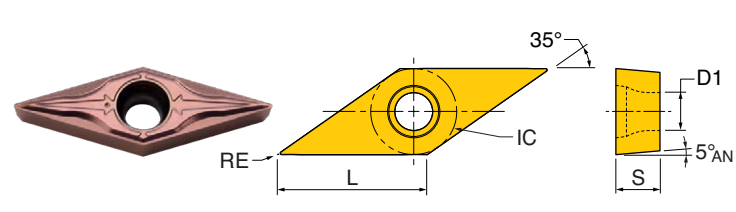

Size	Dimensions (inch)				
	IC Incribed Circle	S Thickness	RE Corner Radius	L Edge Length	D1 Hole Dia.
220	.250	.125	.004	.437	.110
220.5	.250	.125	.008	.437	.110
221	.250	.125	.016	.437	.110

Part Number		ap (inch)		fn (ipr)		PVD Coated	
ANSI	ISO	Depth of Cut		Feed Rate		TT4410	TT4430
		Min.	Max.	Feed Min.	Feed Max.		
INCH							
VCGT220M-SM-F	VCGT110301M-SM-F	.001	.059	.0008	.0047	•	•
VCGT220.5M-SM-F	VCGT110302M-SM-F	.001	.059	.0008	.0047	•	•
VCGT221M-SM-F	VCGT110304M-SM-F	.001	.059	.0012	.0047	•	•

• = Standard Items

Operating Guidelines

DIN ISO 513	Material Group # VDI 3323	Material	Condition	Tensile strength (Kpsi)	Hardness HB	Cutting speed (SFM)		
						Coated		
						TT4410	TT4430	
P	1	Non-alloy steel, cast steel, free cutting steel	<0.25%C	Annealed	61	125	560-1245	525-1215
	2		>=0.25%C	Annealed	94	190	560-1115	525-1115
	3		<0.55%C	Quenched and tempered	123	250	490-885	460-885
	4		>=0.55%C	Annealed	109	220	560-885	525-885
	5		Quenched and tempered	145	300	490-820	460-820	
	6	Low alloy steel and cast steel (less than 5% of alloying elements)	Annealed	87	200	490-885	460-885	
	7		Quenched and tempered	135	275	195-425	195-425	
	8			145	300	165-330	165-330	
	9			174	350	100-330	100-330	
	10	High alloy steel, cast steel and tool steel	Annealed	99	200	195-590	195-590	
	11		Quenched and tempered	160	325	130-260	130-260	
M	12	Stainless steel and cast steel	Ferritic / martensitic	99	200	490-1245	395-885	
	13		Martensitic	119	240	490-885	395-820	
	14		Austenitic	87	180	295-785	295-720	
K	15	Gray cast iron (GG)	Ferritic		180			
	16		Pearlitic		260			
	17	Cast iron nodular (GGG)	Ferritic		160			
	18		Pearlitic		250			
	19	Malleable cast iron	Ferritic		130			
	20		Pearlitic		230			
N	21	Aluminum - wrought alloy	Not cureable		60			
	22		Cured		100			
	23	Aluminum-cast, alloyed	<=12% Si	Not cureable	75			
	24		Cured	90				
	25		>12% Si	High temp.	130			
	26	Copper alloys	>1% Pb	Free cutting	110			
	27		Brass	90				
	28		Electrolitic copper	100				
	29		Non-metallic	Duroplastics, fiber plastics				
	30	Hard rubber						
S	31	High temp. alloys	Fe based	Annealed		200	130-560	130-525
	32			Cured		280	130-490	100-425
	33	Ni or Co based	High temp. alloys	Annealed		250	150-295	115-260
	34			Cured		350	100-260	100-230
	35			Cast		320	100-260	100-195
	36	Titanium, Ti alloys		Rm 58		360-625	295-590	
	37		Alpha+beta alloys cured	Rm 152		165-295	130-260	
H	38	Hardened steel	Hardened		55 HRc			
	39		Hardened		60 HRc			
	40	Chilled cast iron	Cast		400			
	41	Cast iron nodular	Hardened		55 HRc			

■ Steel
 ■ Stainless steel
 ■ Cast iron
 ■ Nonferrous
 ■ High temp. alloys
 ■ Hardened steel