

MILLING - INDEXABLE

Cutter Series (Depth of Cut)

- 15G1B (.024")
- 15G1D, 5G1D (.040")** NEW
- 15G1F, 5G5F, 5G6F (.060")
- 15M1P, 5M5P, 5M6P (.088")
- 5G5Q, 5G6Q (.107")
- 5G5M, 5G6M (.145")

Insert Series

- SDXS04 (4 mm)
- SDXS06 (6 mm)** NEW
- SDXS09 (9 mm)
- SDES13, SDMS13 (13 mm)
- SDXS16 (16 mm)
- SDES19, SDMS19 (19 mm)

Geometries

- MM: Positive Geometry
- MR: Heavy Duty (HD)
- MR1: HD - Keen Edge
- MRH: Hardened Steels
- PH: Positive Geometry

Diameter Range

0.375-7.000"

Grades

- IN2504, IN2505, IN2510, IN2515,
- IN2530, IN2535, IN2537, IN4005,
- IN4015, IN4030, IN4035, IN6537,
- IN7035, **IN05S**

Lead Angle

12°

Adaptions

- Cylindrical, Weldon, TopOn,
- ChipSurfer, Face Mill

Materials

- Steel ■ Stainless Steel
- Cast Iron ■ Non-Ferrous
- High-Temp Alloys
- Hardened Steel

GOLD SFEED™

NEW Ingersoll has Expanded the Proven GoldSFeed Line with a New SDXS06 Insert and Related Cutters

- » Hi-feed, high-positive designed 4-corner insert with wiping flats that can eliminate secondary passes.
- » SDXS06 inserts feature a 12° lead-angle to produce 5x the feed rates in any material.
- » Inserts include multiple types of edge reinforcement and corner configurations.



NEW

13 and 19 mm inserts for hi-feed, precision applications requiring a polished finish

See it in action! »



SPEED UP™
HIGH SPEED & FEED
EXPANSION

NEW

6 mm Expansion

Overview

Our most popular hi-feed mill series, **GoldSFeed** (formerly GoldQuad), is now expanded to include a 6 mm cutter series.

FEATURES & BENEFITS:

- Six hi-feed families offering insert sizes of 4, 6, 9, 13, 16, and 19 mm, multiple cutter - adaptations, pilot sizes and densities.
- Inserts feature 12° lead-angles to produce 5x the feed rates in any material.
- Each cutter family includes light, medium, and heavy duty insert geometries, multiple edge configurations, and our most advanced grades.
- Inserts include multiple types of edge reinforcement and corner configurations.
- All cutter families offer inserts with radial wiping flats that can eliminate secondary passes.



Contents

Series	Pages	Diameter Range	Depth of Cut Max.	Hi-Feed Adaptions					Insert Series (Geometries)
				End Mill - Cylindrical Shank	End Mill - Weldon Shank	End Mill - TopOn	End Mill - ChipSurfer	Face Mill	
4 mm	Products 4-6 Op. Guidelines 21 Programming 22 Ramping Info 23	.375-.750"	.024"	15G1B...	-	15G1B...	15G1B...	-	SDXS04... (MR, MR1, MM)
NEW 6 mm	Products 7-10 Op. Guidelines 24 Programming 25 Ramping Info 26	.625-2.000"	.040"	15G1D...	-	15G1D...	15G1D...	5G1D...	SDXS06... (MR, MR1, MM)
9 mm	Products 11-13 Op. Guidelines 27 Programming 28 Ramping Info 29	1.000-3.000"	.060"	15G1F...	15G1F...	15G1F...	-	5G5F... 5G6F...	SDXS09... (MR, MR1, MM, MRH)
13 mm	Products 14-16 Op. Guidelines 30 Programming 31, 33 Ramping Info 32, 34	1.250-5.000"	.088"	-	15M1P...	15M1P...	-	5M5P... 5M6P...	SDES13... (MR, MR1) SDMS13... (PH, PH-P) NEW
16 mm	Products 17-18 Op. Guidelines 35 Programming 36 Ramping Info 37	2.500-6.000"	.107"	-	-	-	-	5G5Q... 5G6Q...	SDXS16... (MR, MR1, MM)
19 mm	Products 19-20 Op. Guidelines 38 Programming 39, 41 Ramping Info 40, 42	3.000-7.000"	.145"	-	-	-	-	5G5M... 5G6M...	SDES19... (MR, MR1) SDMS19... (PH, PH-P) NEW



4 mm • Series 15G1B

HI-FEED END MILL - CYLINDRICAL SHANK (4 MM INSERT)

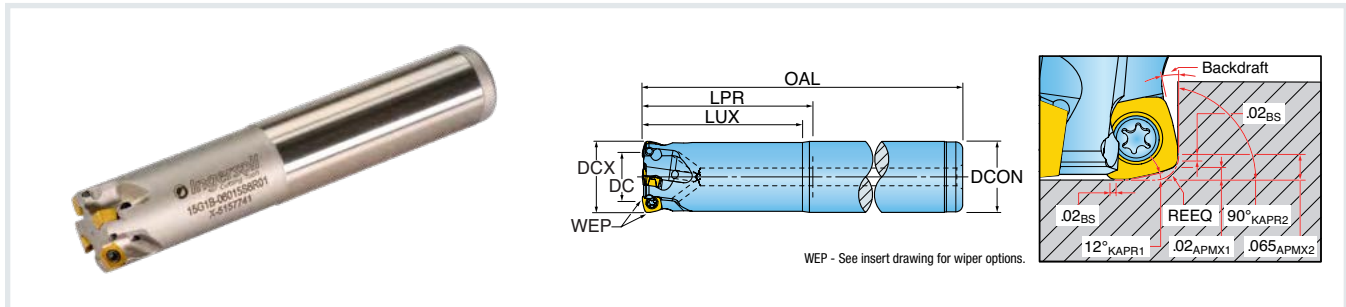

Part Number	DCX Cutting Dia. Max.	DC Cutting Dia.	LUX Usable Length Max.	LPR Protruding Length	REEQ Program Radius Equivalent	OAL Overall Length	ZEFF Effective Teeth	DCON Shank Dia.	RMPX Ramp Angle Max.
INCH									
15G1B-03015R8R01	0.375	0.167	1.300	1.500	0.043	2.920	2	0.375	1.80
15G1B-05015S4R01	0.500	0.291	1.300	1.500	0.042	3.280	3	0.500	4.70
15G1B-06015S6R01	0.625	0.415	1.300	1.500	0.042	3.410	4	0.625	3.00
15G1B-07015S7R01	0.750	0.540	1.300	1.500	0.042	3.500	5	0.750	2.20

Insert screw tightening torque: 5-8 in lb



4 mm • Series 15G1B

HI-FEED END MILL - TOPON (4 MM INSERT)

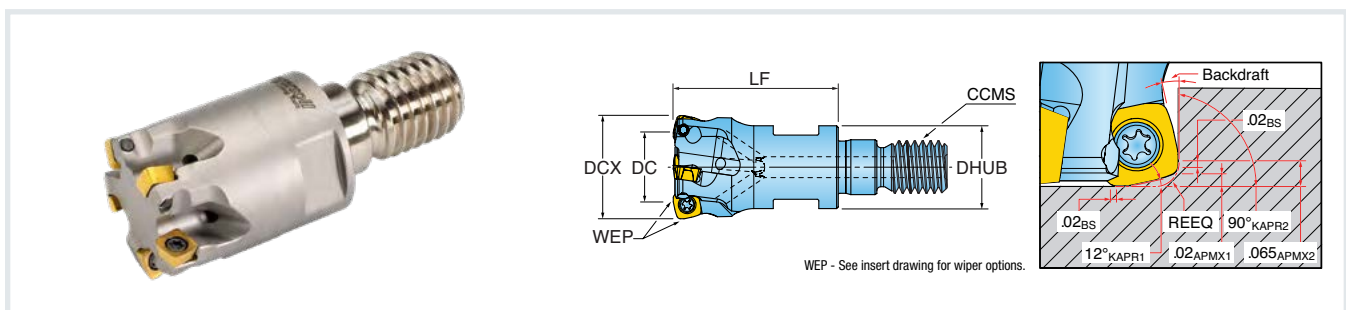

Part Number	DCX Cutting Dia. Max.	DC Cutting Dia.	LF Functional Length	ZEFF Effective Teeth	REEQ Program Radius Equivalent	DHUB Hub Dia.	CCMS Connection Code Machine Side	RMPX Ramp Angle Max.
INCH								
15G1B-05007X4R01	0.500	0.291	0.75	3	0.042	0.465	TopOn M06	4.70
15G1B-06010X5R01	0.625	0.415	1.00	4	0.042	0.505	TopOn M08	3.00
15G1B-07010X6R01	0.750	0.540	1.00	5	0.043	0.704	TopOn M10	2.20

Insert screw tightening torque: 5-8 in lb

4 mm • Series 15G1B

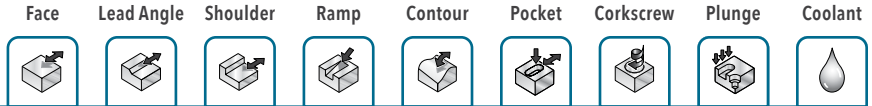

HI-FEED END MILL - CHIPSURFER (4 MM INSERT)

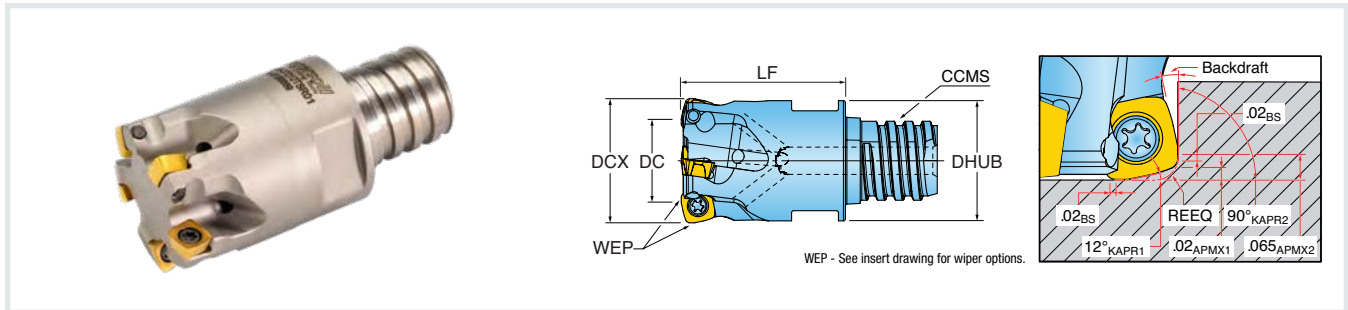

Part Number	DCX Cutting Dia. Max.	DC Cutting Dia.	LF Functional Length	ZEFF Effective Teeth	REEQ Program Radius Equivalent	DHUB Hub Dia.	CCMS Connection Code Machine Side	RMPX Ramp Angle Max.
INCH								
15G1B-03006T6R01	0.375	0.167	0.669	2	0.043	0.369	ChipSurfer T06	1.80
15G1B-05007T8R01	0.500	0.291	0.748	3	0.042	0.485	ChipSurfer T08	4.70
15G1B-06008TRR01	0.625	0.415	0.827	4	0.042	0.605	ChipSurfer T10	3.00
15G1B-07010TSR01	0.750	0.540	1.024	5	0.042	0.725	ChipSurfer T12	2.20

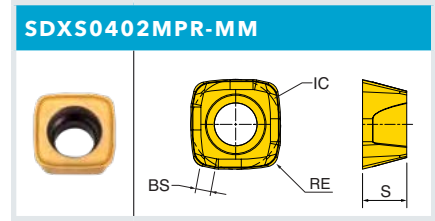
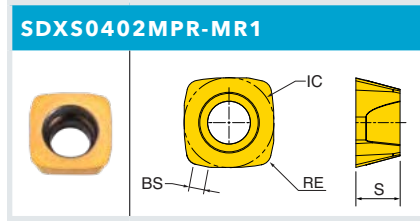
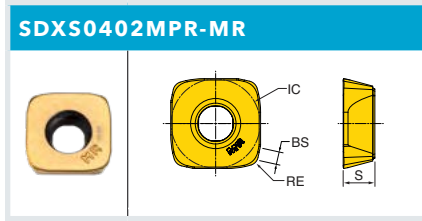
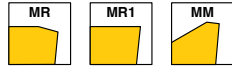

Insert screw tightening torque: 5-8 in lb

4 mm • Inserts •



Part Number	Application	RE Corner Radius	BS Wiper Length	IC Inscribed Circle Dia.	S Thickness	IH Insert Hand	Grade	
							IN2505	IN2530
SDXS0402MPR-MR	Hi-Feed, Heavy Duty	0.021	0.022	4 mm	0.079	Right	•	•
SDXS0402MPR-MR1	Hi-Feed, Heavy Duty Keen Edge	0.021	0.022	4 mm	0.079	Right	•	•
SDXS0402MPR-MM	Hi-Feed, Positive Geometry	0.021	0.022	4 mm	0.079	Right	•	•

4 mm • Hardware

Part Number	 Insert Screw*	 Driver
15G1B-03015R8R01	TS18034I/HG-P	DS-TP06S-NEU
15G1B-05015S4R01	TS18034I/HG-P	DS-TP06S-NEU
15G1B-06015S6R01	SM18-041-00	DS-TP06S-NEU
15G1B-07015S7R01	SM18-041-00	DS-TP06S-NEU
15G1B-03006T6R01	TS18034I/HG-P	DS-TP06S-NEU
15G1B-05007T8R01	TS18034I/HG-P	DS-TP06S-NEU
15G1B-06008TRR01	SM18-041-00	DS-TP06S-NEU
15G1B-07010TSR01	SM18-041-00	DS-TP06S-NEU
15G1B-05007X4R01	TS18034I/HG-P	DS-TP06S-NEU
15G1B-06010X5R01	SM18-041-00	DS-TP06S-NEU
15G1B-07010X6R01	SM18-041-00	DS-TP06S-NEU

*Insert screw tightening torque: 5-8 in lb



6 mm • Series 15G1D

HI-FEED END MILL - CYLINDRICAL SHANK (6 MM INSERT)

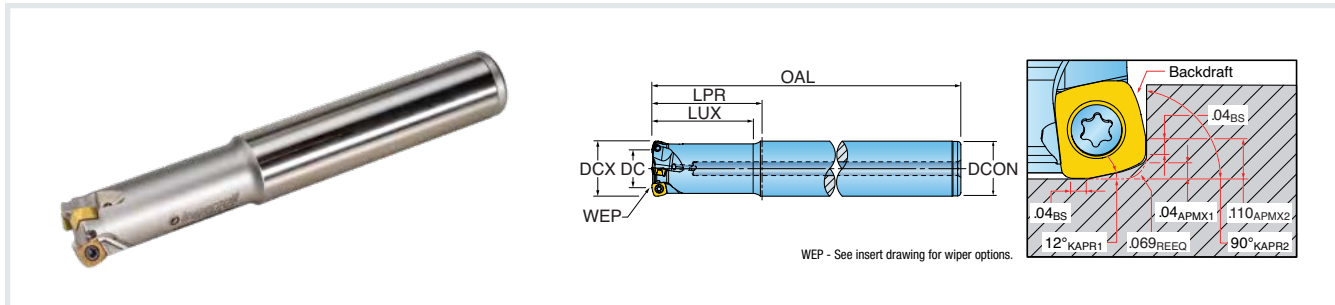

Part Number	DCX Cutting Dia. Max.	DC Cutting Dia.	LUX Usable Length Max.	LPR Protruding Length	OAL Overall Length	ZEFF Effective Teeth	REEQ Program Radius Equivalent	DCON Shank Dia.	RMPX Ramp Angle Max.
INCH									
15G1D-06015S6R01	0.625	0.314	1.500	1.500	4.000	2	0.069	0.625	2.50
15G1D-07020S7R01	0.750	0.438	2.000	2.000	5.000	3	0.069	0.750	3.50
15G1D-07030S7R01	0.750	0.438	3.000	3.000	6.000	3	0.069	0.750	3.50
15G1D-08020S8R01	0.875	0.562	2.000	2.000	7.000	4	0.069	0.875	3.00
15G1D-10020S1R01	1.000	0.686	2.000	2.000	10.000	4	0.069	1.000	2.50
15G1D-10030S1R01	1.000	0.686	3.000	3.000	7.000	4	0.069	1.000	2.50
15G1D-12030S9R01	1.250	0.936	3.000	3.000	5.500	5	0.069	1.250	2.00

Insert screw tightening torque: 10-14 in lb



6 mm • Series 15G1D

HI-FEED END MILL - TOPON (6 MM INSERT)

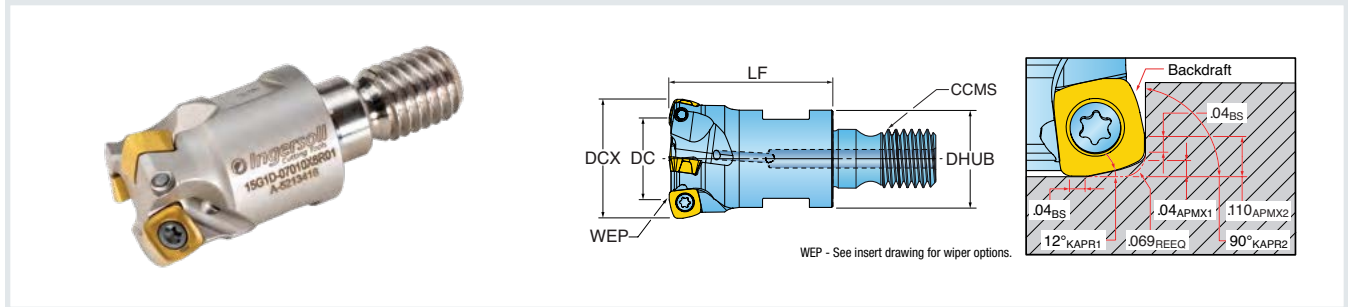

Part Number	DCX Cutting Dia. Max.	DC Cutting Dia.	LF Functional Length	ZEFF Effective Teeth	REEQ Program Radius Equivalent	DHUB Hub Dia.	CCMS Connection Code Machine Side	RMPX Ramp Angle Max.
INCH								
15G1D-06010X5R01	0.625	0.314	1.000	2	0.069	0.50	TopOn M08	2.50
15G1D-07010X6R01	0.750	0.438	1.000	3	0.069	0.70	TopOn M10	3.50
15G1D-08010X7R01	0.875	0.562	1.000	4	0.069	0.70	TopOn M12	3.00
15G1D-10013X7R01	1.000	0.686	1.380	4	0.069	0.82	TopOn M12	2.50
15G1D-12015X8R01	1.250	0.936	1.500	5	0.069	1.13	TopOn M16	2.00
15G1D-15015X8R01	1.500	1.186	1.500	6	0.069	1.13	TopOn M16	1.60
15G1D-15017X9R01	1.500	1.186	1.750	6	0.069	1.42	TopOn M20	1.60

Insert screw tightening torque: 10-14 in lb



6 mm • Series 15G1D

HI-FEED END MILL - CHIPSURFER (6 MM INSERT)

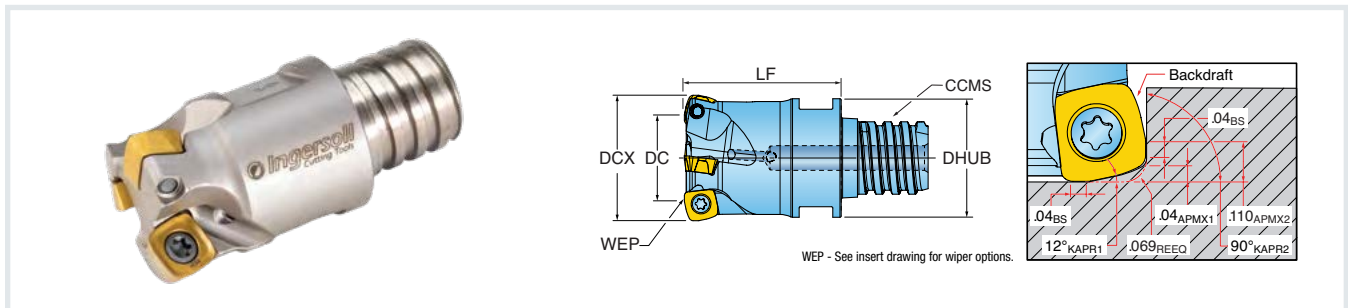

Part Number	DCX Cutting Dia. Max.	DC Cutting Dia.	LF Functional Length	ZEFF Effective Teeth	REEQ Program Radius Equivalent	DHUB Hub Dia.	CCMS Connection Code Machine Side	RMPX Ramp Angle Max.
INCH								
15G1D-06008TRR01	0.625	0.314	0.83	2	0.069	0.61	ChipSurfer T10	2.50
15G1D-07010TSR01	0.750	0.438	1.00	3	0.069	0.72	ChipSurfer T12	3.50
15G1D-10012TUR01	1.000	0.686	1.25	4	0.069	0.97	ChipSurfer T15	2.50

Insert screw tightening torque: 10-14 in lb



6 mm • Series 5G1D

HI-FEED FACE MILL (6 MM INSERT)

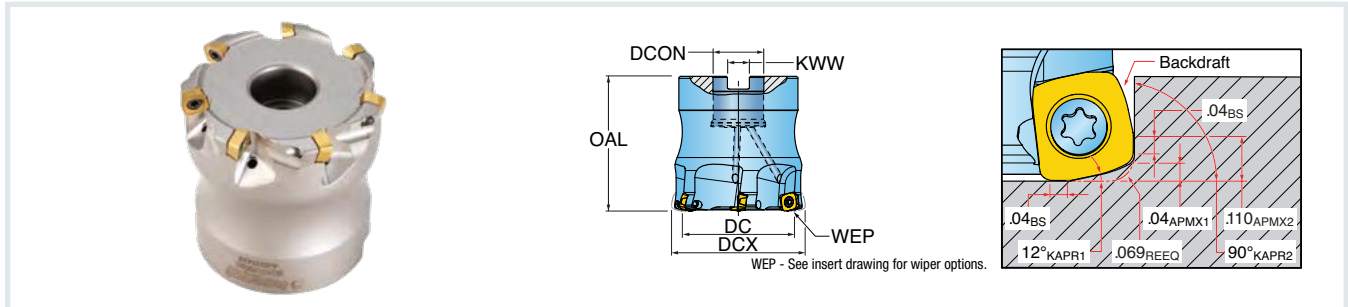

Part Number	DCX Cutting Dia. Max.	DC Cutting Dia.	OAL Overall Length	ZEFF Effective Teeth	REEQ Program Radius Equivalent	DCON Bore Dia.	KWW Keyway	RMPX Ramp Angle Max.
INCH								
5G1D-15R01	1.500	1.186	1.500	6	0.069	0.500	0.25	1.60
5G1D-20R01	2.000	1.686	2.000	6	0.069	0.750	0.31	1.00
5G1D-20R02	2.000	1.686	2.000	7	0.069	0.750	0.31	1.00

Insert screw tightening torque: 10-14 in lb

6 mm • Inserts •

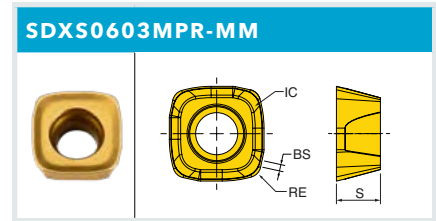
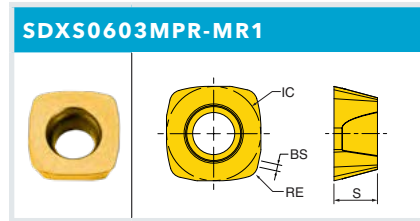
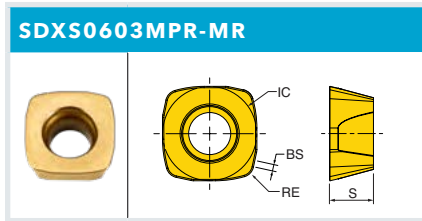
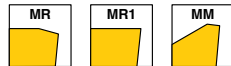

Part Number	Application	RE Corner Radius	BS Wiper Length	IC Inscribed Circle Dia.	S Thickness	NOI No. of Indexes	IH Insert Hand	Grades												
								IN2504	IN2510	IN4005	IN2505	IN4030	IN2530	IN4035	IN2535	IN7035	IN6537	IN2537		
SDXS0603MPR-MR	Hi-Feed, Heavy Duty	0.034	0.041	6 mm	0.118	4	Right	•	•	•	•	•	•	•	•	•	•	•	•	•
SDXS0603MPR-MR1	Hi-Feed, Heavy Duty Keen Edge	0.034	0.041	6 mm	0.118	4	Right				•	•	•	•	•	•				
SDXS0603MPR-MM	Hi-Feed, Positive Geometry	0.034	0.041	6 mm	0.118	4	Right			•	•	•	•	•	•	•				

6 mm • Hardware

Part Number	Optional						
	Insert Screw*	Driver	Retention Bolt	Coolant Bolt	Torque Driver Handle	Preset Torque Adapter	Torque Driver Bit
15G1D...	SM25-054-00	DS-0020	-	-	DS-A00-.25-S	DT-11-.25	DS-T08B
5G1D-15R01	SM25-054-00	DS-0020	SD-04-46	-	DS-A00-.25-S	DT-11-.25	DS-T08B
5G1D-20R01	SM25-054-00	DS-0020	SD-06-48	SD-06-A6	DS-A00-.25-S	DT-11-.25	DS-T08B
5G1D-20R02	SM25-054-00	DS-0020	SD-06-48	SD-06-A6	DS-A00-.25-S	DT-11-.25	DS-T08B

*Insert screw tightening torque: 10-14 in lb

9 mm • Series 15G1F



HI-FEED END MILL - CYLINDRICAL SHANK (9 MM INSERT)

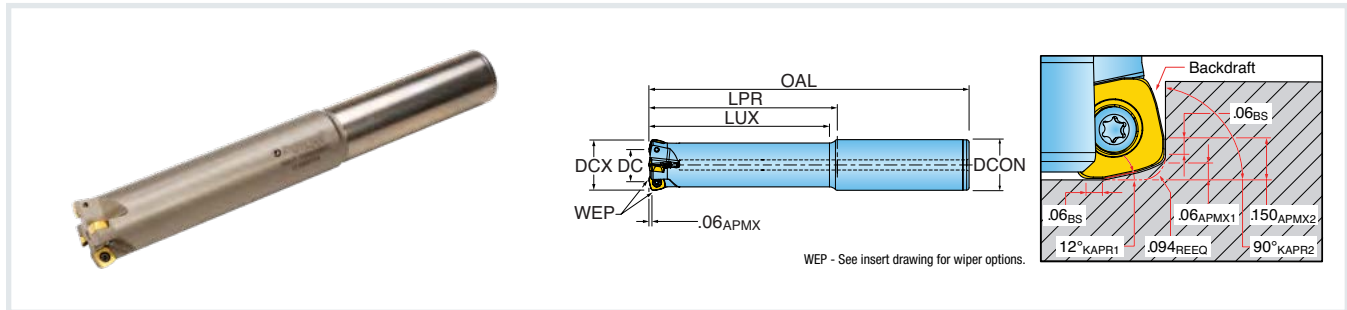

Part Number	DCX Cutting Dia. Max.	DC Cutting Dia.	LUX Usable Length Max.	LPR Protruding Length	OAL Overall Length	ZEFF Effective Teeth	REEQ Program Radius Equivalent	KAPR Cutting Edge Angle	DCON Shank Dia.	RMPX Ramp Angle Max.
INCH										
15G1F-10019S1R01	1.000	0.524	1.78	1.97	7.00	3	0.094	12°	1.000	5.5
15G1F-10020S1R01	1.000	0.524	1.81	2.00	10.00	3	0.094	12°	1.000	5.5
15G1F-12047S9R01	1.250	0.773	4.55	4.75	8.00	3	0.094	12°	1.250	3.3
15G1F-12047S9R02	1.250	0.773	4.55	4.75	8.00	4	0.094	12°	1.250	3.3
15G1F-15060S9R01	1.500	1.022	6.00	6.00	10.00	4	0.094	12°	1.250	2.3
15G1F-15060S9R02	1.500	1.022	6.00	6.00	10.00	5	0.094	12°	1.250	2.3

Insert screw tightening torque: 14-18 in lb

9 mm • Series 15G1F



HI-FEED END MILL - WELDON SHANK (9 MM INSERT)

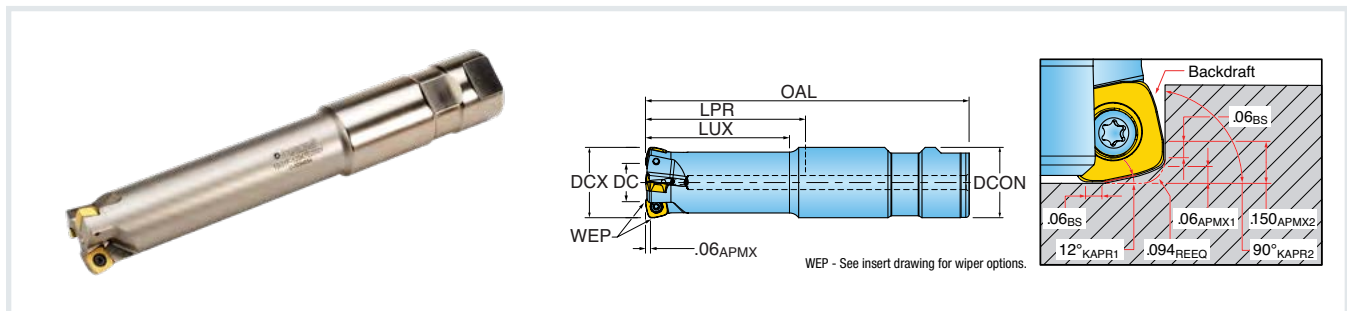

Part Number	DCX Cutting Dia. Max.	DC Cutting Dia.	LUX Usable Length Max.	LPR Protruding Length	OAL Overall Length	ZEFF Effective Teeth	REEQ Program Radius Equivalent	KAPR Cutting Edge Angle	DCON Shank Dia.	RMPX Ramp Angle Max.
INCH										
15G1F-12027E2R01	1.250	0.773	2.55	2.75	5.75	3	0.094	12°	1.250	3.3
15G1F-12027E2R02	1.250	0.773	2.55	2.75	5.75	4	0.094	12°	1.250	3.3
15G1F-12047E2R01	1.250	0.773	4.55	4.75	7.75	3	0.094	12°	1.250	3.3
15G1F-15016E2R01	1.500	1.022	1.69	1.69	6.00	4	0.094	12°	1.250	2.3
15G1F-15016E2R02	1.500	1.022	1.69	1.69	6.00	5	0.094	12°	1.250	2.3

Insert screw tightening torque: 14-18 in lb



9 mm • Series 15G1F

HI-FEED END MILL - TOPON (4 MM INSERT)

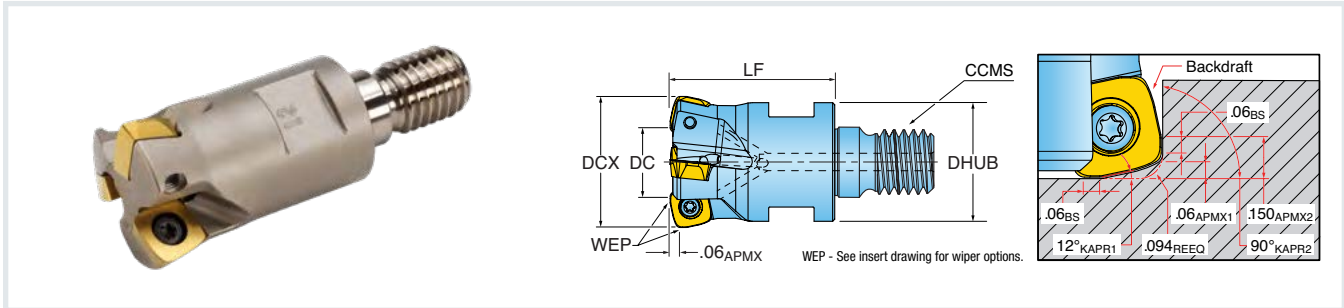

Part Number	DCX Cutting Dia. Max.	DC Cutting Dia.	LF Functional Length	ZEFF Effective Teeth	REEQ Program Radius Equivalent	KAPR Cutting Edge Angle	DHUB Hub Dia.	CCMS Connection Code Machine Side	RMPX Ramp Angle Max.
INCH									
15G1F-10015X7R01	1.000	0.524	1.57	3	0.094	12°	0.82	TopOn M12	5.5
15G1F-12015X8R02	1.250	0.773	1.57	4	0.094	12°	1.13	TopOn M16	3.3
15G1F-15017X9R01	1.500	1.022	1.57	5	0.094	12°	1.42	TopOn M20	2.3

Insert screw tightening torque: 14-18 in lb



9 mm • Series 5G5F, 5G6F

HI-FEED FACE MILL (6 MM INSERT)

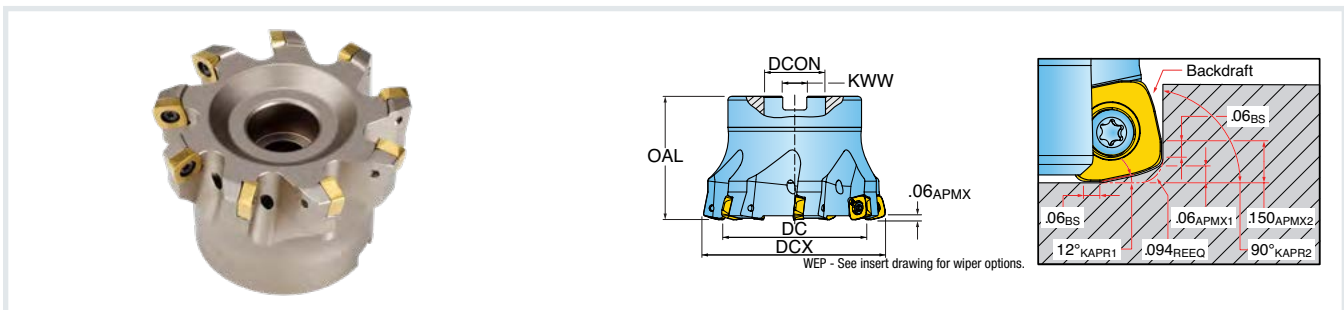

Part Number	DCX Cutting Dia. Max.	DC Cutting Dia.	OAL Overall Length	ZEFF Effective Teeth	REEQ Program Radius Equivalent	DCON Bore Dia.	KWW Keyway	RMPX Ramp Angle Max.
INCH								
5G5F-20R01	2.000	1.521	1.97	7	0.094	0.750	0.31	1.5
5G6F-20R01	2.000	1.521	1.97	6	0.094	0.750	0.31	1.5
5G5F-25R01	2.500	2.020	1.97	8	0.094	0.750	0.31	1.1
5G5F-30R01	3.000	2.520	2.00	9	0.094	1.000	0.38	0.8
5G6F-30R01	3.000	2.520	2.00	7	0.094	1.000	0.38	0.8

Insert screw tightening torque: 14-18 in lb

9 mm • Inserts •

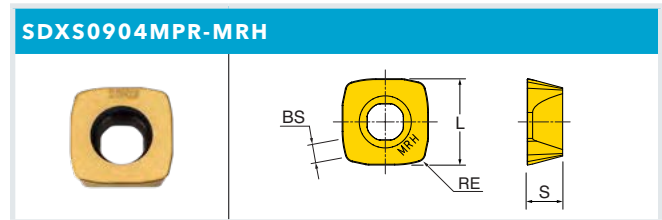
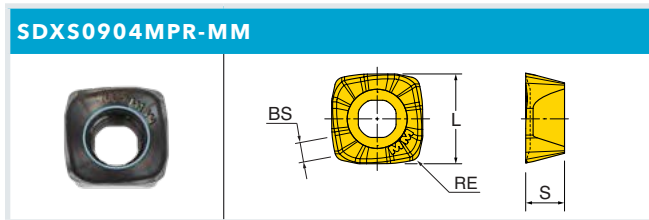
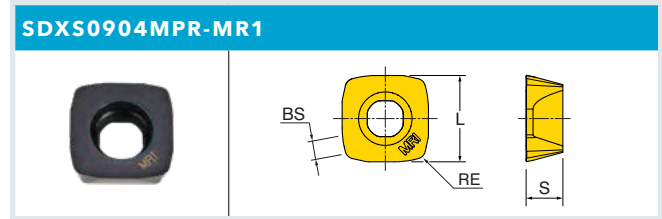
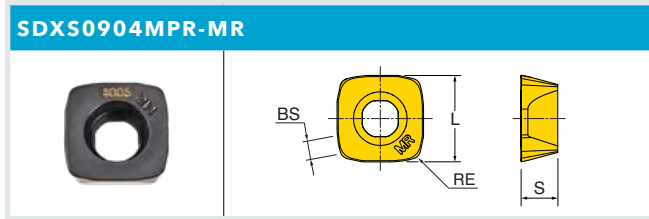

Part Number	Application	RE Corner Radius	BS Wiper Length	L Cutting Edge Length	S Thickness	Grade							
						IN2504	IN4005	IN2505	IN4030	IN2530	IN7035	IN4035	IN2535
SDXS0904MPR-MR	Heavy Duty	0.040	0.060	0.370	0.158		•	•	•	•		•	•
SDXS0904MPR-MR1	Flat-Top, Keen Edge	0.040	0.060	0.370	0.158				•	•	•	•	•
SDXS0904MPR-MM	Multi-Purpose	0.040	0.060	0.370	0.158		•	•	•	•	•	•	•
SDXS0904MPR-MRH	Hardened Steels	0.040	0.060	0.370	0.158	•							

9 mm • Hardware

Part Number	Optional			
	Insert Screw*	Driver	Retention Bolt	Coolant Bolt
15G1F...	SM30-075-R0	DS-T09W	-	-
5G5F-20R01	SM30-075-R0	DS-T09W	SD-06-48	SD06-A6
5G6F-20R01	SM30-075-R0	DS-T09W	SD-06-48	SD06-A6
5G5F-25R01	SM30-075-R0	DS-T09W	SD-06-48	SD06-A6
5G5F-30R01	SM30-075-R0	DS-T09W	SD-08-47	SD-08-C9
5G6F-30R01	SM30-075-R0	DS-T09W	SD-08-47	SD-08-C9

*Insert screw tightening torque: 14-18 in lb

13 mm • Series 15M1P



HI-FEED END MILL - WELDON SHANK (13 MM INSERT)

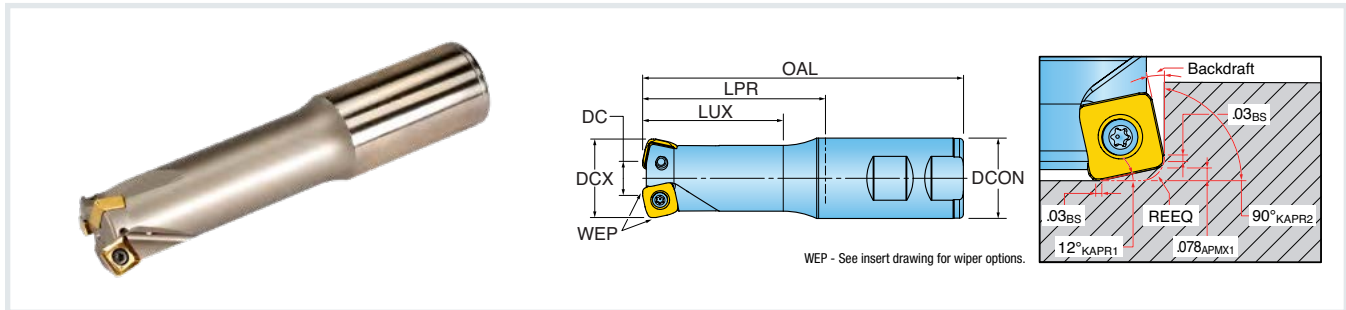

Part Number	DCX Cutting Dia. Max.	DC Cutting Dia.	LUX Usable Length Max.	LPR Protruding Length	OAL Overall Length	ZEFF Effective Teeth	REEQ Program Radius Equivalent	DCON Shank Dia.	RMPX* Ramp Angle Max.
INCH									
15M1P-1202781R01	1.250	0.423	2.00	2.75	5.00	2	0.125	1.250 Weldon	13.10
15M1P-1204759R01	1.250	0.423	4.00	4.75	8.00	2	0.125	1.250 Cylindrical	13.10
15M1P-1502786R01	1.500	0.673	2.00	2.75	5.41	3	0.125	1.500 Weldon	7.10
15M1P-1505386R01	1.500	0.673	5.00	5.34	8.00	3	0.125	1.500 Weldon	7.10

*All of the above data is with insert SDES1305MDR-MR installed. Please see Technical Literature for dimensions when using other inserts.
Insert screw tightening torque: 30-35 in lb

13 mm • Series 15M1P



HI-FEED END MILL - TOPON (13 MM INSERT)

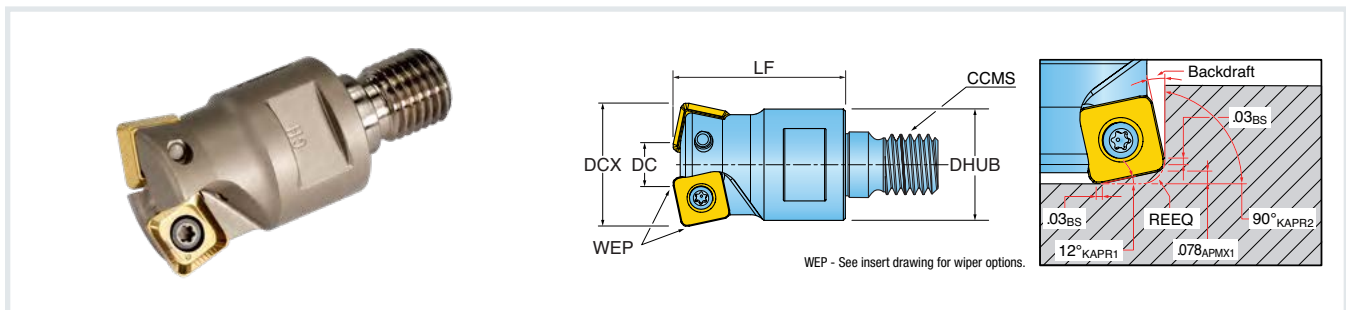

Part Number	DCX Cutting Dia. Max.	DC Cutting Dia.	APMX Depth of Cut Max.	LF Functional Length	ZEFF Effective Teeth	REEQ Program Radius Equivalent	DHUB Hub Dia.	CCMS Connection Code Machine Side	RMPX* Ramp Angle Max.
INCH									
15M1P-12017X8R01	1.250	0.423	0.088	1.75	2	0.125	1.13	TopOn M16	13.10

*All of the above data is with insert SDES1305MDR-MR installed. Please see Technical Literature for dimensions when using other inserts.
Insert screw tightening torque: 30-35 in lb

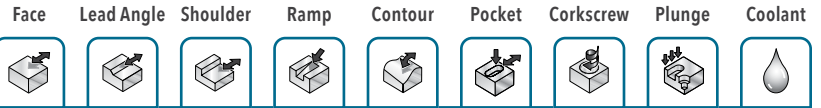

13 mm • Series 5M5P, 5M6P

HI-FEED FACE MILL (13 MM INSERT)

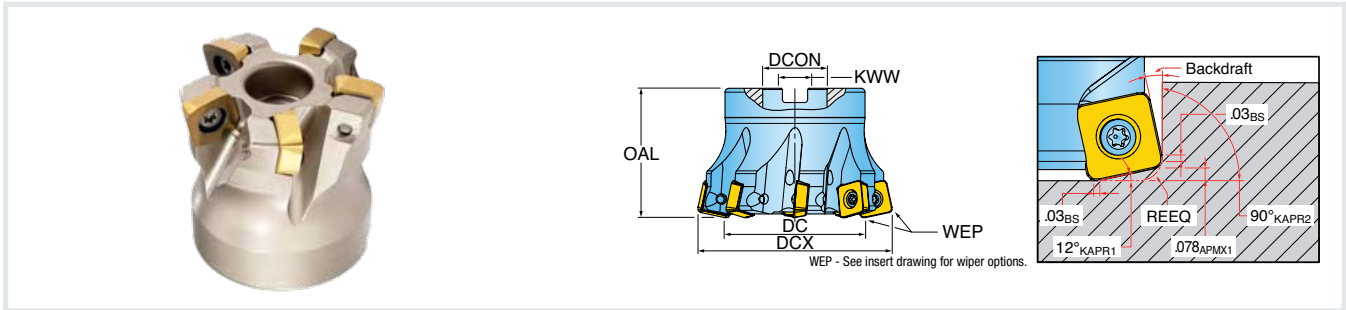

Part Number	DCX Cutting Dia. Max.	DC Cutting Dia.	OAL Overall Length	ZEFF Effective Teeth	DCON Bore Dia.	KWW Keyway	RMPX* Ramp Angle Max.	REEQ Program Radius Equivalent
INCH								
5M5P-20R01	2.000	1.170	2.000	5	0.750	0.313	3.90	0.125
5M6P-20R01	2.000	1.170	2.000	4	0.750	0.313	3.90	0.125
5M5P-25R01	2.500	1.670	2.000	6	0.750	0.313	2.70	0.125
5M6P-25R01	2.500	1.670	2.000	5	0.750	0.313	2.70	0.125
5M5P-30R01	3.000	2.170	2.000	8	1.000	0.375	1.60	0.125
5M5P-30R02	3.000	2.170	2.000	8	1.250	0.500	1.60	0.125
5M6P-30R01	3.000	2.170	2.000	6	1.000	0.375	1.60	0.125
5M6P-30R02	3.000	2.170	2.000	6	1.250	0.500	1.60	0.125
5M5P-40R01	4.000	3.170	2.500	10	1.500	0.625	1.10	0.125
5M6P-40R01	4.000	3.170	2.500	8	1.500	0.625	1.10	0.125
5M5P-50R01	5.000	4.170	2.500	11	1.500	0.625	0.80	0.125
5M6P-50R01	5.000	4.170	2.500	9	1.500	0.625	0.80	0.125

*All of the above data is with insert SDES1305MDR-MR installed. Please see Technical Literature for dimensions when using other inserts.
Insert screw tightening torque: 30-35 in lb

13 mm • Inserts •

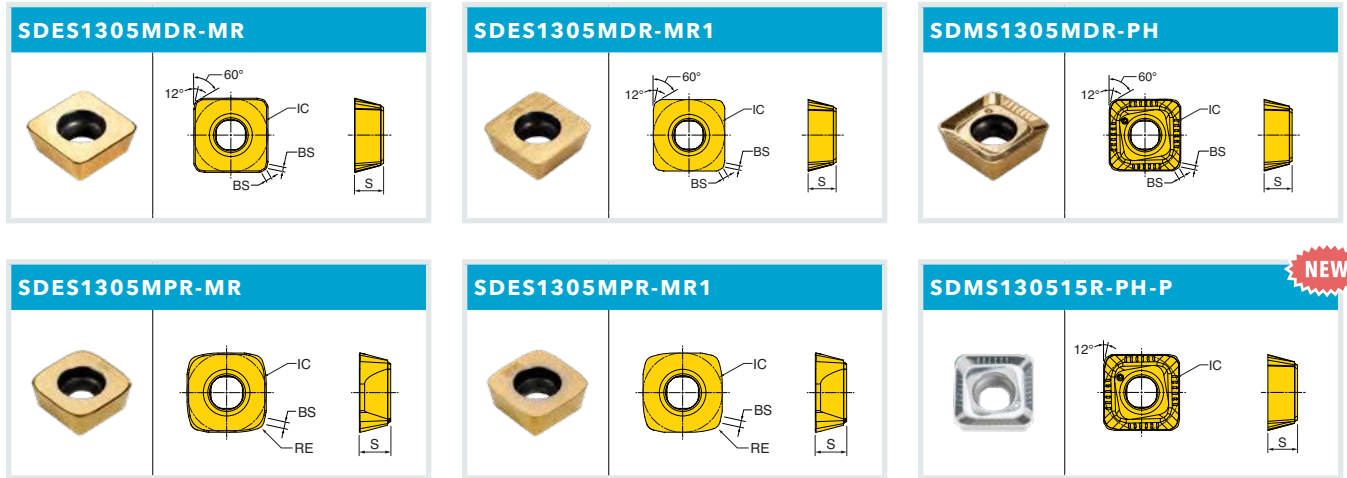
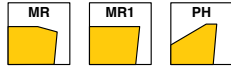

Part Number	Application	RE Corner Radius	BS Wiper Length	IC Inscribed Circle	S Thickness	Grade					
						IN2505	IN2530	IN4005	IN4030	IN4035	IN05S
SDES1305MDR-MR	Hi-Feed, Flat Face / Wiper - Facets	0.125	0.030	13 mm	.200	•	•				
SDES1305MDR-MR1	Hi-Feed, Precision Flat Face / Wiper - Facets	0.125	0.030	13 mm	.200	•	•				
SDMS1305MDR-PH	Hi-Feed, Pos Precision / Wiper - Facets	0.125	0.030	13 mm	.200	•	•	•	•	•	
SDES1305MPR-MR	Hi-Feed, Heavy Duty - Standard	0.140	0.060	13 mm	.200	•	•	•		•	
SDES1305MPR-MR1	Hi-Feed, Heavy Duty - Precision	0.140	0.060	13 mm	.200	•	•	•	•	•	
NEW SDMS130515R-PH-P	Hi-Feed, Precision - Polished	0.078	-	13 mm	.200						•

13 mm • Hardware

Part Number	Optional				
	Insert Screw*	Driver	Driver Bit	Retention Bolt	Coolant Bolt
15M1P...	SM40-100-R0	DS-A00T	BLD T15/S7	-	-
5M5P-20R01	SM40-100-R0	DS-A00T	BLD T15/S7	SD-06-48	SD06-A6
5M6P-20R01	SM40-100-R0	DS-A00T	BLD T15/S7	SD-06-48	SD06-A6
5M5P-25R01	SM40-100-R0	DS-A00T	BLD T15/S7	SD-06-48	SD06-A6
5M6P-25R01	SM40-100-R0	DS-A00T	BLD T15/S7	SD-06-48	SD06-A6
5M5P-30R01	SM40-100-R0	DS-A00T	BLD T15/S7	SD-08-47	SD-08-92
5M6P-30R01	SM40-100-R0	DS-A00T	BLD T15/S7	SD-08-47	SD-08-92
5M5P-30R02	SM40-100-R0	DS-A00T	BLD T15/S7	SD-10-47	SD-10-99
5M6P-30R02	SM40-100-R0	DS-A00T	BLD T15/S7	SD-10-47	SD-10-99
5M5P-40R01	SM40-100-R0	DS-A00T	BLD T15/S7	SD-12-82	SD-12-99
5M6P-40R01	SM40-100-R0	DS-A00T	BLD T15/S7	SD-12-82	SD-12-99
5M5P-50R01	SM40-100-R0	DS-A00T	BLD T15/S7	SD-12-82	SD-12-99
5M6P-50R01	SM40-100-R0	DS-A00T	BLD T15/S7	SD-12-82	SD-12-99

*Insert screw tightening torque: 30-35 in lb

16 mm • Series 5G5Q, 5G6Q

Face Lead Angle Shoulder Ramp Contour Pocket Corkscrew Plunge Coolant

HI-FEED FACE MILL (16 MM INSERT)

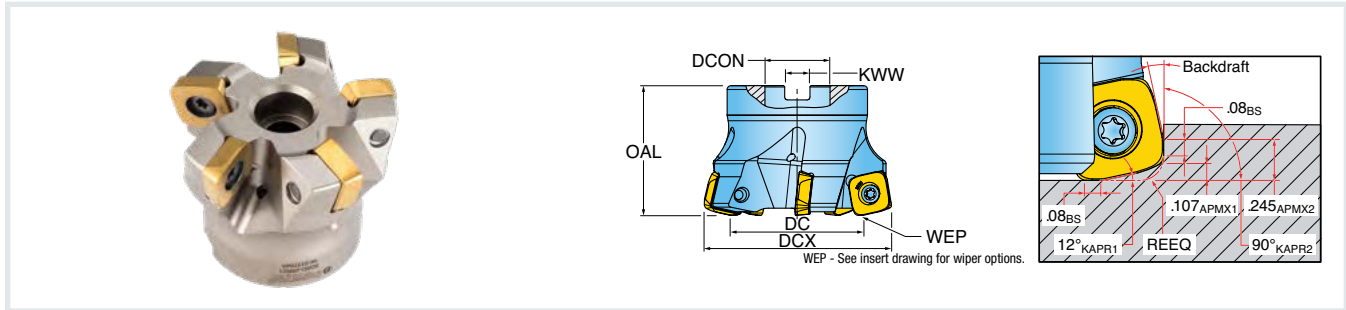

Part Number	DCX Cutting Dia. Max.	DC Cutting Dia.	APMX Depth of Cut Max.	OAL Overall Length	ZEFF Effective Teeth	REEQ Program Radius Equivalent	DCON Bore Dia.	KWW Keyway	RMPX* Ramp Angle Max.
INCH									
5G5Q-25R01	2.500	1.645	0.107	2.000	5	0.167	0.750	0.31	3.3
5G5Q-25R02	2.500	1.645	0.107	2.000	5	0.167	1.000	0.38	3.3
5G5Q-30R01	3.000	2.144	0.107	2.000	6	0.167	1.000	0.38	2.4
5G6Q-30R01	3.000	2.144	0.107	2.000	5	0.167	1.000	0.38	2.4
5G5Q-30R02	3.000	2.144	0.107	2.000	6	0.167	1.250	0.50	2.4
5G5Q-40R01	4.000	3.144	0.107	2.500	8	0.166	1.500	0.63	1.6
5G6Q-40R01	4.000	3.144	0.106	2.500	6	0.166	1.500	0.63	1.6
5G6Q-50R01	5.000	4.144	0.106	2.500	8	0.166	1.500	0.63	1.2
5G6Q-60R01	6.000	5.144	0.106	2.500	9	0.166	1.500	0.63	0.9



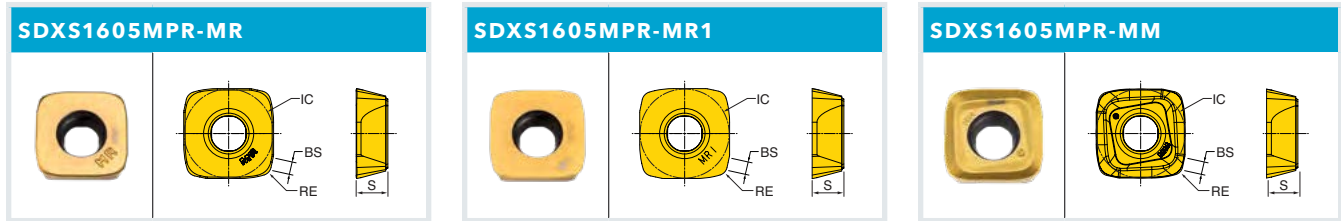
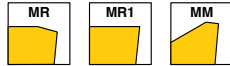

Insert screw tightening torque: 40-45 in lb

16 mm • Inserts •



Part Number	Application	RE Corner Radius	BS Wiper Length	IC Inscribed Circle	S Thickness	NOI Number of Indexes	IH Insert Hand	Grade										
								IN2505	IN2515	IN2530	IN2535	IN4005	IN4015	IN4030	IN4035	IN7035		
SDXS1605MPR-MR	Utility Insert - Heavy Duty	0.210	0.079	16 mm	0.220	4	Right	•		•	•	•					•	
SDXS1605MPR-MR1	Utility Insert - Heavy Duty Keen Edge	0.210	0.079	16 mm	0.220	4	Right	•	•	•	•	•	•				•	•
SDXS1605MPR-MM	Positive Geometry	0.210	0.079	16 mm	0.220	4	Right	•	•	•	•	•	•	•	•	•	•	•

16 mm • Hardware

Part Number	 Insert Screw*	 Retention Bolt	 Driver Handle	 Torx Driver Blade
5G5Q-25R01	SM50-130-R0	SD-06-48	DS-A00T	DS-T206B
5G5Q-25R02	SM50-130-R0	SD-08-48	DS-A00T	DS-T206B
5G5Q-30R01	SM50-130-R0	SD-08-47	DS-A00T	DS-T206B
5G6Q-30R01	SM50-130-R0	SD-08-47	DS-A00T	DS-T206B
5G5Q-30R02	SM50-130-R0	SD-10-47	DS-A00T	DS-T206B
5G5Q-40R01	SM50-130-R0	SD-12-82	DS-A00T	DS-T206B
5G6Q-40R01	SM50-130-R0	SD-12-82	DS-A00T	DS-T206B
5G6Q-50R01	SM50-130-R0	SD-12-82	DS-A00T	DS-T206B
5G6Q-60R01	SM50-130-R0	SD-12-82	DS-A00T	DS-T206B

*Insert screw tightening torque: 40-45 in lb

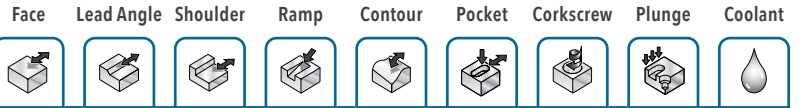

19 mm • Series 5G5M, 5G6M

HI-FEED FACE MILL (19 MM INSERT)

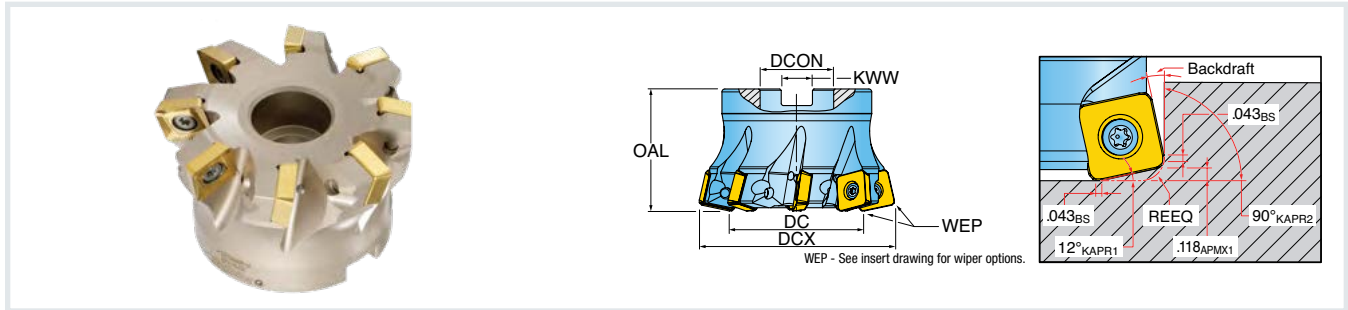

Part Number	DCX Cutting Dia. Max.	DC Cutting Dia.	OAL Overall Length	ZEFF Effective Teeth	DCON Bore Dia.	KWW Keyway	RMPX* Ramp Angle Max.	REEQ Program Radius Equivalent
INCH								
5G5M-30R01	3.000	1.755	2.000	6	1.000	0.375	2.70	0.180
5G6M-30R01	3.000	1.755	2.000	5	1.000	0.375	4.40	0.180
5G5M-40R01	4.000	2.755	2.500	8	1.500	0.625	1.70	0.180
5G6M-40R01	4.000	2.755	2.500	6	1.500	0.625	2.60	0.180
5G5M-50R01	5.000	3.755	2.500	9	1.500	0.625	1.70	0.180
5G6M-50R01	5.000	3.755	2.500	7	1.500	0.625	1.90	0.180
5G5M-60R01	6.000	4.755	2.500	10	1.500	0.625	1.30	0.180
5G6M-60R01	6.000	4.755	2.500	8	1.500	0.625	1.50	0.180
5G6M-70R01	7.000	5.755	2.500	8	1.500	0.625	1.23	0.180

*All of the above data is with insert SDES1906MDR-MR installed. Please see Technical Literature for dimensions when using other inserts.
Insert screw tightening torque: 72-77 in lb

19 mm • Inserts •

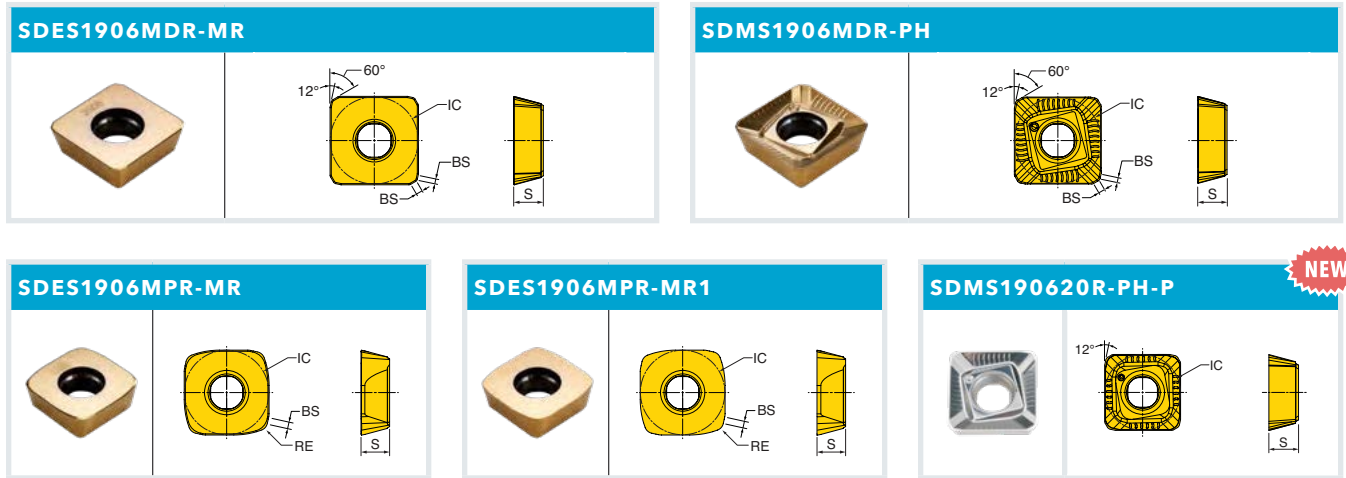
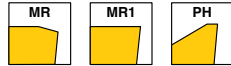

NEW

Part Number	Application	RE Corner Radius	BS Wiper Length	IC Inscribed Circle	S Thickness	Grade					
						IN2505	IN2530	IN4005	IN4030	IN4035	IN05S
SDES1906MDR-MR	Hi-Feed, Flat Face / Wiper - Facets	0.180	0.043	19 mm	.250	•	•				
SDMS1906MDR-PH	Hi-Feed, Pos Precision / Wiper - Facets	0.180	0.043	19 mm	.250	•	•	•	•	•	
SDES1906MPR-MR	Hi-Feed, Heavy Duty - Standard	0.212	0.061	19 mm	.250	•	•	•		•	
SDES1906MPR-MR1	Hi-Feed, Heavy Duty - Precision	0.212	0.061	19 mm	.250	•	•	•	•	•	
NEW SDMS190620R-PH-P	Hi-Feed, Precision - Polished	0.250	-	19 mm	.250						•

19 mm • Hardware

Part Number	Optional			
	Insert Screw*	Driver	Retention Bolt	Coolant Bolt
5G5M-30R01	SM60-135-R0	DS-T25T	SD-08-47	SD-08-92
5G6M-30R01	SM60-135-R0	DS-T25T	SD-08-47	SD-08-92
5G5M-40R01	SM60-135-R0	DS-T25T	SD-12-82	SD-12-99
5G6M-40R01	SM60-135-R0	DS-T25T	SD-12-82	SD-12-99
5G5M-50R01	SM60-135-R0	DS-T25T	SD-12-82	SD-12-99
5G6M-50R01	SM60-135-R0	DS-T25T	SD-12-82	SD-12-99
5G5M-60R01	SM60-135-R0	DS-T25T	SD-12-82	SD-12-99
5G6M-60R01	SM60-135-R0	DS-T25T	SD-12-82	SD-12-99
5G6M-70R01	SM60-135-R0	DS-T25T	SD-12-82	SD-12-99

*Insert screw tightening torque: 72-77 in lb

4 mm • Operating Guidelines

AXIAL CHIP THINNING

NOTE: The operating guidelines table below includes a column for feed-per-tooth (fz). That column accounts for the axial chip thinning that's generated by the cutting-edge angle (lead angle). All GoldSFeed high-feed cutters have a 12° cutting edge angle resulting in an fz that is approximately 5x the recommended chip thickness (hex).

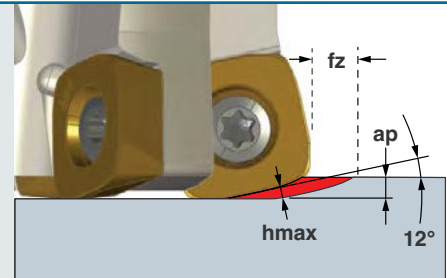

ISO	Materials			Vc Cutting Speed SFM	Hex Max. Chip Thickness (inch)	fz* Feed/Tooth (inch)	Harder «----» Tougher		Coolant	Geometry		
	Mat'l Group #VDI 3323	Type	Examples				IN2505	IN2530		MR	MR1	MM
P	1-5	Non-alloy steel	1018, A36, 1045, A572, 1070	600-1000	.002-.008	.010-.040	1	2	No	1	2	3
	6-9	Low-alloy steel	4140, 4340, P20, 8620, 300M	500-800	.002-.006	.010-.030	1	2	No	1	2	3
	10, 11	High-alloy steel	H13, A2, D2, M2, T1	400-700	.002-.004	.010-.020	1	2	No	1	2	3
M	12, 13	Stainless steel (ferritic & martensitic)	410, 416, 440	400-700	.002-.004	.010-.020	2	1	Yes	-	1	2
	14	Stainless steel (austenitic)	303, 304, 316, 15-5, 17-4	500-800	.002-.006	.010-.030	2	1	Yes	-	2	1
K	15, 16	Gray cast iron	CLS. 20, 30, 45	600-1000	.002-.008	.010-.040	1	2	No	3	1	2
	17-20	Nodular cast iron	60-40-18, 100-70-03	500-800	.002-.006	.010-.030	1	2	No	3	1	2
N	21-30	Aluminum	7075, 6061	1000+	.004-.008	.020-.040	1	2	Yes	-	2	1
S	31-35	High-temp alloys	Inconel, Hastelloy, Nimonic, Monel	80-140	.001-.003	.005-.015	2	1	Yes	-	1	2
	36, 37	Titanium alloys	6Al-4V, 5Al-5Mo-5V-3Cr	100-200	.002-.005	.010-.025	2	1	Yes	-	1	2
H	38, 39	Hardened steel >48	A2, O1, D2	100-200	.001-.004	.005-.020	1	2	No	1	-	-

Note: Feed and speed recommendations are starting operating parameters. They are only guidelines from which further optimization should take place. Operating parameters are influenced by many machining variables. These variables may cause for reductions in feeds and speed or dramatic increases. Additionally, DOC and WOC may need to be revised to optimize the tools performance.

4 mm • Programming Data

DEFINITIONS

- » **DCX:** maximum cutting diameter
- » **DC:** effective cutter diameter
- » **KAPR:** cutting edge angle
- » **APMX:** maximum depth of cut
- » **REEQ:** program radius
- » **BS:** axial wiper length
- » **BS2:** radial wiper length

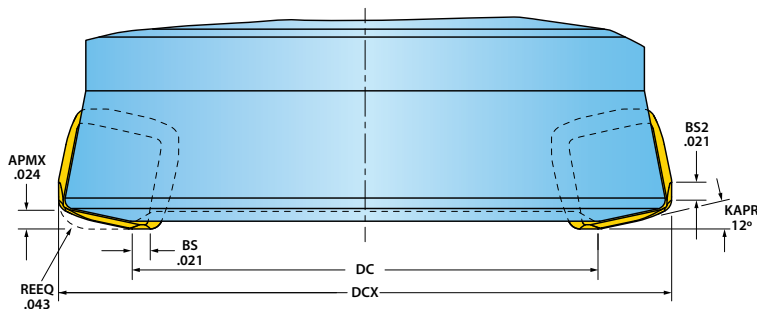

Part Number	DCX Cutting Dia. Max.	DC Cutting Dia.
15G1B-03006T6R01	0.375	0.167
15G1B-03015R8R01	0.375	0.167
15G1B-05007T8R01	0.500	0.291
15G1B-05007X4R01	0.500	0.291
15G1B-05015S4R01	0.500	0.291
15G1B-06008TRR01	0.625	0.415
15G1B-06010X5R01	0.625	0.415
15G1B-06015S6R01	0.625	0.415
15G1B-07010TSR01	0.750	0.540
15G1B-07010X6R01	0.750	0.540
15G1B-07015S7R01	0.750	0.540

4 mm • Programming Tips

- » The shape of the insert nose can be approximated by programming as-if the insert had a **.042"** corner radius (REEQ). The difference will result in an unmachined area that's approximately **.013"** deep.
- » The recommendations for cutting speed, chip-thickness grade, and insert geometry are starting recommendations and should be optimized based on the type and rate of edge failure.
- » The **Machining Calculator App**, on Ingersoll's website, is another resource for estimating and optimizing parameters. There are additional inputs like the radial width of cut and the effective rake angle can be included into the estimates.

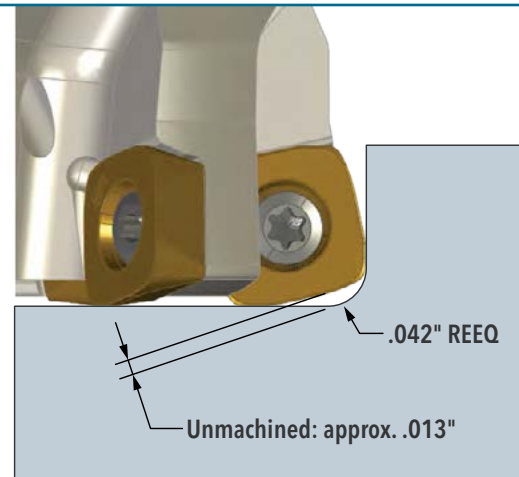

4 mm • Straight Ramping

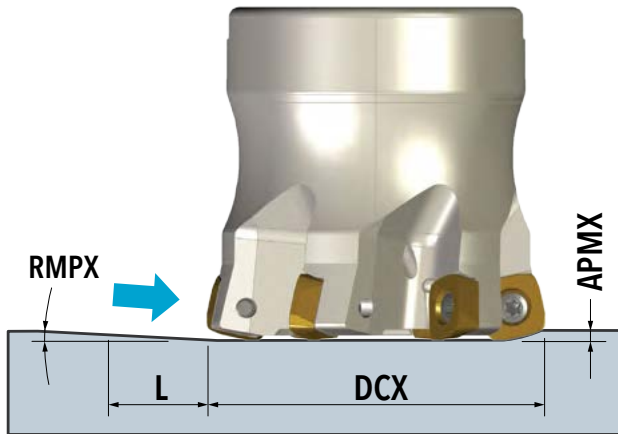

DCX Cutting Dia. Max.	RMPX Ramp Angle Max.	L*	APMX Depth of Cut Max.
0.375	1.80	0.763	0.024
0.500	4.70	0.279	0.024
0.625	3.00	0.438	0.024
0.750	2.20	0.598	0.024

* L in this table is the length the cutter travels to reach the maximum depth of cut (.024") while traveling at the maximum ramp angle listed for the cutter.

4 mm • Helical Ramping

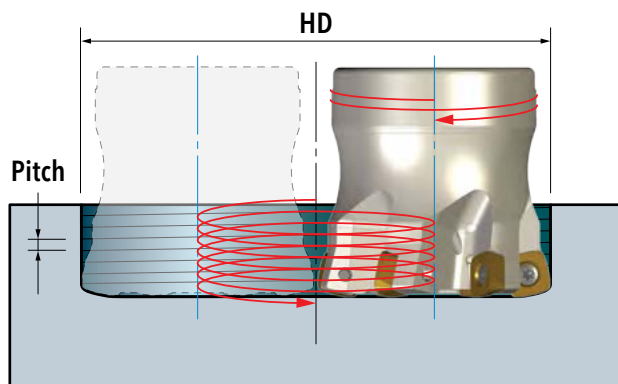

PITCH

The maximum pitch is determined to not exceed the maximum depth of cut (APMX) and to not exceed the maximum ramp angle (RMPX).

DCX Cutting Dia. Max.	HD Hole Dia. Min.	HD Hole Dia. Max.	HD Hole Dia. Max. w/o Cusp	Max. Pitch Per Revolution
0.375	0.476	0.750	0.542	0.024
0.500	0.704	1.000	0.791	0.024
0.625	0.952	1.250	1.040	0.024
0.750	1.202	1.500	1.290	0.024

EXAMPLE

- » The minimum hole diameter that the **.375"** diameter cutter can interpolate from solid is **.476"** (leaving a raised cusp).
- » The maximum hole diameter that the **.375"** diameter cutter can interpolate from solid is **.750"**.
- » The maximum hole diameter that the **.375"** diameter cutter can interpolate from solid while leaving a flat-bottom is **.542"** (leaving no raised cusp).
- » The maximum pitch for this series matches the insert's radial wiper length of **.024"**.

6 mm • Operating Guidelines

AXIAL CHIP THINNING

NOTE: The operating guidelines table below includes a column for feed-per-tooth (fz). That column accounts for the axial chip thinning that's generated by the cutting-edge angle (lead angle). All GoldSFeed high-feed cutters have a 12° cutting edge angle resulting in an fz that is approximately 5x the recommended chip thickness (hex).

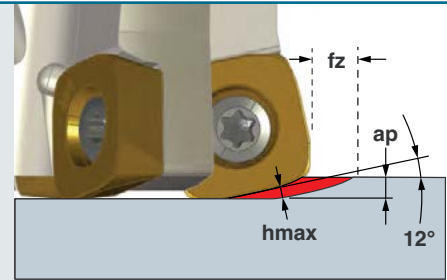

ISO	Materials			Vc Cutting Speed SFM	Hex Max. Chip Thickness (inch)	fz* Feed/ Tooth (inch)	Harder «-----» Tougher										Coolant	Geometry		
	Mat'l Group #VDI 3323	Type	Examples				IN2504	IN2510	IN4005	IN2505	IN4030	IN2530	IN6537	IN7035	IN4035	IN2535		MR	MR1	MM
P	1-5	Non-alloy steel	1018, A36, 1045, A572, 1070	500-900	.004-.010	.020-.050	-	-	-	1	4	2	3	-	-	-	No	1	2	3
	6-9	Low-alloy steel	4140, 4340, P20, 8620, 300M	400-600	.003-.008	.015-.040	-	-	-	1	4	2	3	-	-	-	No	1	2	3
	10, 11	High-alloy steel	H13, A2, D2, M2, T1	300-500	.003-.008	.015-.040	-	-	-	1	4	2	3	-	-	-	No	1	2	3
M	12, 13	Stainless steel (ferritic & martensitic)	410, 416, 440	400-700	.003-.008	.015-.040	-	-	-	-	2	1	-	-	4	3	Yes	-	1	2
	14	Stainless steel (austenitic)	303, 304, 316, 15-5, 17-4	300-600	.003-.008	.015-.040	-	-	-	-	2	1	-	-	4	3	Yes	-	2	1
K	15, 16	Gray cast iron	CLS. 20, 30, 45	500-900	.004-.010	.020-.050	-	1	2	3	4	-	-	-	-	-	No	3	1	2
	17, 18	Ductile cast iron	60-40-18, 100-70-03	400-600	.003-.008	.015-.040	-	-	1	2	3	4	-	-	-	-	No	3	1	2
N	21-30	Aluminum	7075, 6061	1000+	.004-.010	.020-.050	-	-	1	2	3	4	-	-	-	-	Yes	-	2	1
S	31-35	High-temp alloys	Inconel, Hastelloy, Monel	80-140	.002-.004	.010-.020	-	-	-	-	-	-	-	2	3	1	Yes	-	1	2
	36, 37	Titanium alloys	6Al-4V, 5Al-5Mo-5V-3Cr	100-200	.004-.006	.020-.030	-	-	-	-	-	-	-	3	2	1	Yes	-	1	2
H	38, 39	Hardened steel >48	A2, O1, D2	100-200	.002-.004	.010-.020	1	-	3	2	-	-	-	-	-	-	No	1	-	-

Note: Feed and speed recommendations are starting operating parameters. They are only guidelines from which further optimization should take place. Operating parameters are influenced by many machining variables. These variables may cause for reductions in feeds and speed or dramatic increases. Additionally, DOC and WOC may need to be revised to optimize the tools performance.

6 mm • Programming Data

DEFINITIONS

- » **DCX:** maximum cutting diameter
- » **DC:** effective cutter diameter
- » **KAPR:** cutting edge angle
- » **APMX:** maximum depth of cut
- » **REEQ:** program radius
- » **BS:** axial wiper length
- » **BS2:** radial wiper length

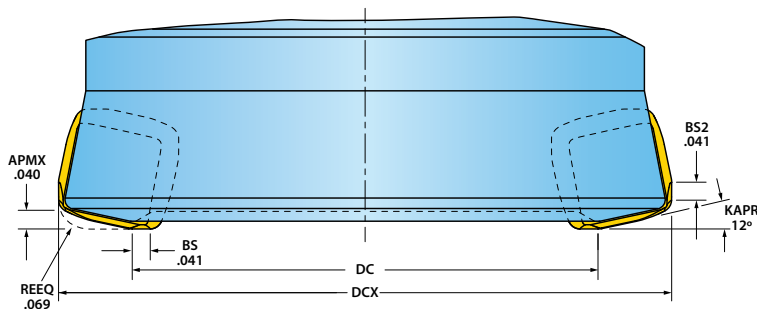

Part Number	DCX Cutting Dia. Max.	DC Cutting Dia.
15G1D-06015S6R01	0.625	0.314
15G1D-07020S7R01	0.750	0.438
15G1D-07030S7R01	0.750	0.438
15G1D-08020S8R01	0.875	0.562
15G1D-10020S1R01	1.000	0.686
15G1D-10030S1R01	1.000	0.686
15G1D-12030S9R01	1.250	0.936
15G1D-06010X5R01	0.625	0.314
15G1D-07010X6R01	0.750	0.438
15G1D-08010X7R01	0.875	0.562
15G1D-10013X7R01	1.000	0.686
15G1D-12015X8R01	1.250	0.936
15G1D-15015X8R01	1.500	1.186
15G1D-15017X9R01	1.500	1.186
15G1D-06008TRR01	0.625	0.314
15G1D-07010TSR01	0.750	0.438
15G1D-10012TUR01	1.000	0.686
5G1D-15R01	1.500	1.186
5G1D-20R01	2.000	1.686
5G1D-20R02	2.000	1.686

6 mm • Programming Tips

- » The shape of the insert nose can be approximated by programming as-if the insert had a **.069"** corner radius (REEQ). The difference will result in an unmachined area that's approximately **.0186"** deep.
- » The recommendations for cutting speed, chip-thickness grade, and insert geometry are starting recommendations and should be optimized based on the type and rate of edge failure.
- » The [Machining Calculator App](#), on Ingersoll's website, is another resource for estimating and optimizing parameters. There are additional inputs like the radial width of cut and the effective rake angle can be included into the estimates.

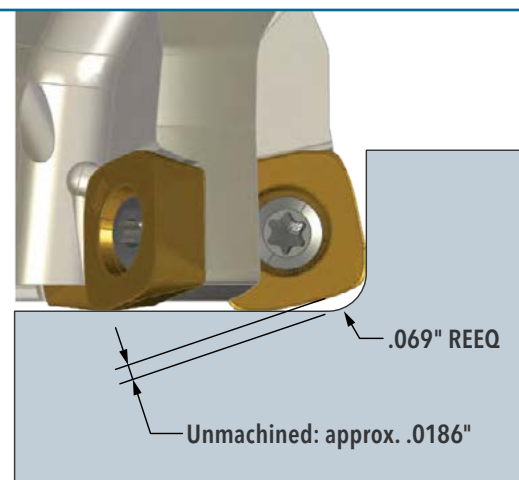

6 mm • Straight Ramping

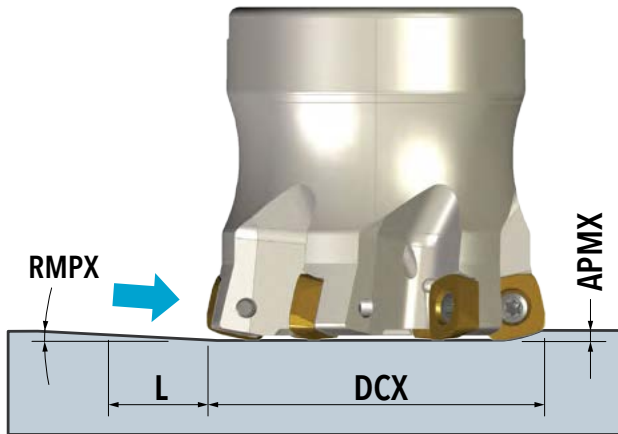

DCX Cutting Dia. Max.	RMPX Ramp Angle Max.	L*	APMX Depth of Cut Max.
0.625	2.500	0.916	0.040
0.750	3.500	0.653	0.040
0.875	3.000	0.763	0.040
1.000	2.500	0.916	0.040
1.250	2.000	1.145	0.040
1.500	1.600	1.432	0.040
2.000	1.000	2.291	0.040

* L in this table is the length the cutter travels to reach the maximum depth of cut (.040") while traveling at the maximum ramp angle listed for the cutter.

6 mm • Helical Ramping

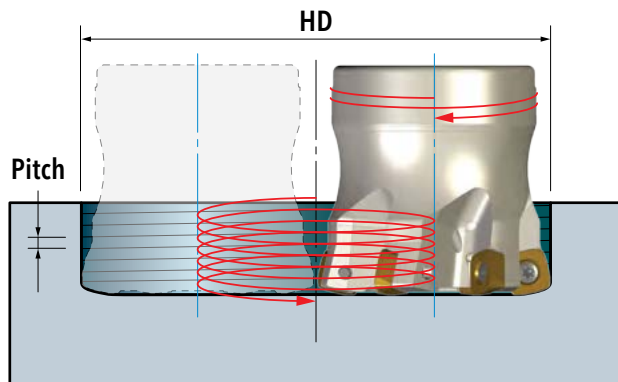

DCX Cutting Dia. Max.	HD Hole Dia. Min.	HD Hole Dia. Max.	HD Hole Dia. Max. w/o Cusp	Max. Pitch Per Revolution
0.625	0.812	1.250	0.939	0.040
0.750	1.044	1.500	1.188	0.040
0.875	1.288	1.750	1.437	0.040
1.000	1.538	2.000	1.686	0.040
1.250	2.032	2.500	2.186	0.040
1.500	2.534	3.000	2.686	0.040
2.000	3.534	4.000	3.686	0.040

PITCH

The maximum pitch is determined to not exceed the maximum depth of cut (APMX) and to not exceed the maximum ramp angle (RMPX).

EXAMPLE

- » The minimum hole diameter that the **.625"** diameter cutter can interpolate from solid is **.812"** (leaving a raised cusp).
- » The maximum hole diameter that the **.625"** diameter cutter can interpolate from solid is **1.250"**.
- » The maximum hole diameter that the **.625"** diameter cutter can interpolate from solid while leaving a flat-bottom is **.939"** (leaving no raised cusp).
- » The maximum pitch for this series matches the insert's radial wiper length of **.040"**.

9 mm • Operating Guidelines

AXIAL CHIP THINNING

NOTE: The operating guidelines table below includes a column for feed-per-tooth (fz). That column accounts for the axial chip thinning that's generated by the cutting-edge angle (lead angle). All GoldSFeed high-feed cutters have a 12° cutting edge angle resulting in an fz that is approximately 5x the recommended chip thickness (hex).

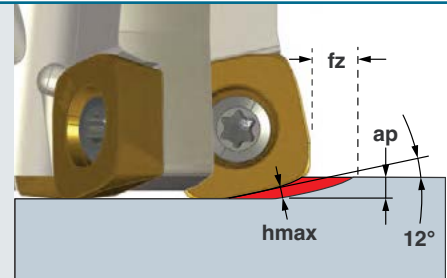

ISO	Materials			Vc Cutting Speed SFM	Hex Max. Chip Thickness (inch)	fz* Feed/ Tooth (inch)	Harder «-----» Tougher								Coolant	Geometry			
	Mat'l Group #VDI 3323	Type	Examples				IN2504	IN4005	IN2505	IN4030	IN2530	IN7035	IN4035	IN2535		MR	MR1	MM	MRH
P	1-5	Non-alloy steel	1018, A36, 1045, A572, 1070	500-900	.006-.014	.030-.070	-	1	2	3	4	-	-	-	No	1	2	3	-
	6-9	Low-alloy steel	4140, 4340, P20, 8620, 300M	400-600	.005-.012	.025-.060	-	1	2	3	4	-	-	-	No	1	2	3	-
	10, 11	High-alloy steel	H13, A2, D2, M2, T1	300-500	.004-.010	.020-.050	-	1	2	3	4	-	-	-	No	1	2	3	-
M	12, 13	Stainless steel (ferritic & martensitic)	410, 416, 440	400-700	.004-.010	.020-.050	-	-	-	2	1	-	4	3	Yes	-	1	2	-
	14	Stainless steel (austenitic)	303, 304, 316, 15-5, 17-4	300-600	.004-.010	.020-.050	-	-	-	2	1	-	4	3	Yes	-	2	1	-
K	15, 16	Gray cast iron	CLS. 20, 30, 45	500-900	.006-.015	.030-.075	-	1	2	3	4	-	-	-	No	3	1	2	-
	17-20	Nodular cast iron	60-40-18, 100-70-03	400-600	.005-.012	.025-.060	-	1	2	3	4	-	-	-	No	3	1	2	-
N	21-30	Aluminum	7075, 6061	1000+	.004-.015	.020-.075	-	1	2	3	4	-	-	Yes	-	2	1	-	
S	31-35	High-temp alloys	Inconel, Hastelloy, Nimonic, Monel	80-140	.002-.005	.010-.025	-	-	-	-	-	2	3	1	Yes	-	1	2	-
	36, 37	Titanium alloys	6Al-4V, 5Al-5Mo-5V-3Cr	100-200	.005-.008	.025-.040	-	-	-	-	-	3	1	2	Yes	-	1	2	-
H	38, 39	Hardened steel >48	A2, O1, D2	100-200	.002-.004	.010-.020	1	2	3	-	-	-	-	-	No	2	-	-	1

Note: Feed and speed recommendations are starting operating parameters. They are only guidelines from which further optimization should take place. Operating parameters are influenced by many machining variables. These variables may cause for reductions in feeds and speed or dramatic increases. Additionally, DOC and WOC may need to be revised to optimize the tools performance.

9 mm • Programming Data

DEFINITIONS

- » **DCX:** maximum cutting diameter
- » **DC:** effective cutter diameter
- » **KAPR:** cutting edge angle
- » **APMX:** maximum depth of cut
- » **REEQ:** program radius
- » **BS:** axial wiper length
- » **BS2:** radial wiper length

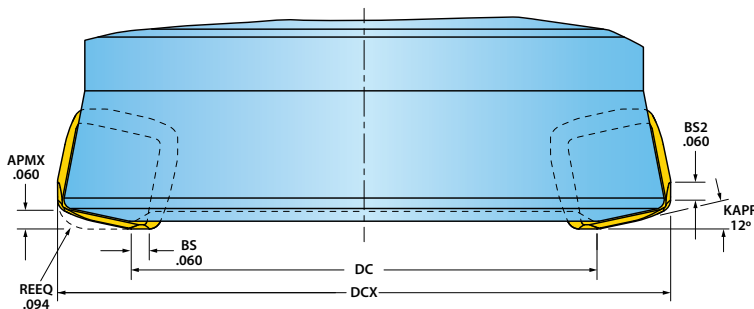

Part Number	DCX Cutting Dia. Max.	DC Cutting Dia.
15G1F-10019S1R01	1.000	0.524
15G1F-10020S1R01	1.000	0.524
15G1F-10015X7R01	1.000	0.524
15G1F-12047S9R02	1.250	0.773
15G1F-12047S9R01	1.250	0.773
15G1F-12027E2R02	1.250	0.773
15G1F-12027E2R01	1.250	0.773
15G1F-12047E2R01	1.250	0.773
15G1F-12015X8R02	1.250	0.773
15G1F-15060S9R02	1.500	1.022
15G1F-15060S9R01	1.500	1.022
15G1F-15016E2R02	1.500	1.022
15G1F-15016E2R01	1.500	1.022
15G1F-15017X9R01	1.500	1.022
5G5F-20R01	2.000	1.521
5G6F-20R01	2.000	1.521
5G5F-25R01	2.500	2.020
5G5F-30R01	3.000	2.520
5G6F-30R01	3.000	2.520

9 mm • Programming Tips

- » The shape of the insert nose can be approximated by programming as-if the insert had a **.094"** corner radius (REEQ). The difference will result in an unmachined area that's approximately **.030"** deep.
- » The recommendations for cutting speed, chip-thickness grade, and insert geometry are starting recommendations and should be optimized based on the type and rate of edge failure.
- » The [Machining Calculator App](#), on Ingersoll's website, is another resource for estimating and optimizing parameters. There are additional inputs like the radial width of cut and the effective rake angle can be included into the estimates.

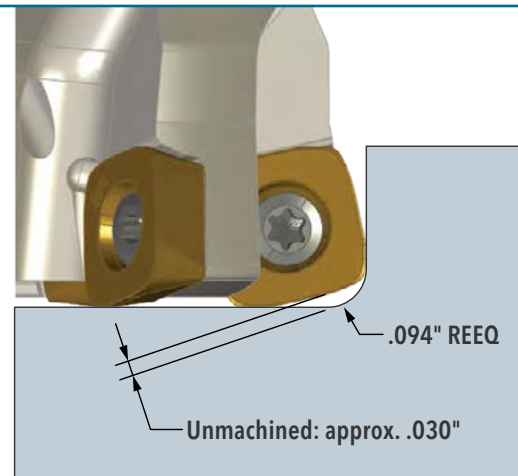

9 mm • Straight Ramping

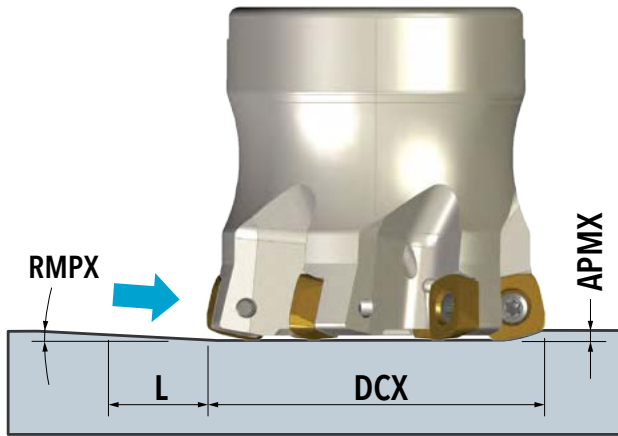

DCX Cutting Dia. Max.	RMPX Ramp Angle Max.	L*	APMX Depth of Cut Max.
1.000	5.5	0.623	0.060
1.250	3.3	1.041	0.060
1.500	2.3	1.494	0.060
2.000	1.5	2.291	0.060
2.500	1.1	3.125	0.060
3.000	0.8	4.297	0.060

* L in this table is the length the cutter travels to reach the maximum depth of cut (.060") while traveling at the maximum ramp angle listed for the cutter.

9 mm • Helical Ramping

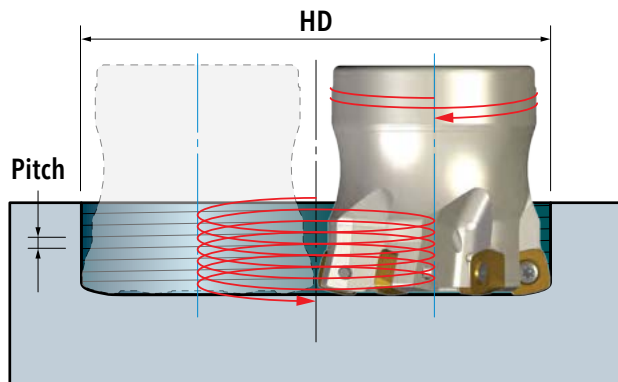

PITCH

The maximum pitch is determined to not exceed the maximum depth of cut (APMX) and to not exceed the maximum ramp angle (RMPX).

DCX Cutting Dia. Max.	HD Hole Dia. Min.	HD Hole Dia. Max.	HD Hole Dia. Max. w/o Cusp	Max. Pitch Per Revolution
1.000	1.324	2.000	1.524	0.060
1.250	1.822	2.500	2.023	0.060
1.500	2.320	3.000	2.522	0.060
2.000	3.320	4.000	3.520	0.060
2.500	4.330	5.000	4.520	0.060
3.000	5.330	6.000	5.520	0.060

EXAMPLE

- » The minimum hole diameter that the **1.000"** diameter cutter can interpolate from solid is **1.324"** (leaving a raised cusp).
- » The maximum hole diameter that the **1.000"** diameter cutter can interpolate from solid is **2.000"**.
- » The maximum hole diameter that the **1.000"** diameter cutter can interpolate from solid while leaving a flat-bottom is **1.542"** (leaving no raised cusp).
- » The maximum pitch for this series matches the insert's radial wiper length of **.060"**.

13 mm • Operating Guidelines

AXIAL CHIP THINNING

NOTE: The operating guidelines table below includes a column for feed-per-tooth (fz). That column accounts for the axial chip thinning that's generated by the cutting-edge angle (lead angle). All GoldSFeed high-feed cutters have a 12° cutting edge angle resulting in an fz that is approximately 5x the recommended chip thickness (hex).

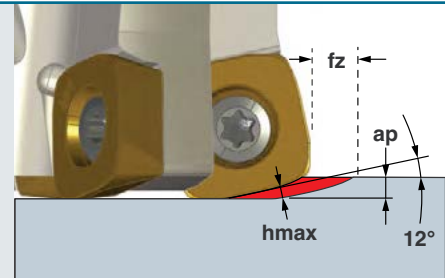

ISO	Materials			Vc Cutting Speed SFM	Hex Max. Chip Thickness (inch)	fz* Feed/ Tooth (inch)	Harder «-----» Tougher								Coolant	Geometry		
	Mat'l Group #VDI 3323	Type	Examples				IN4005	IN2505	IN4030	IN2530	IN7035	IN4035	IN2535	IN055		MR	MR1	PH
P	1-5	Non-alloy steel	1018, A36, 1045, A572, 1070	450-750	.006-.018	.030-.090	1	2	3	4	-	-	-	-	No	1	2	3
	6-9	Low-alloy steel	4140, 4340, P20, 8620, 300M	350-550	.005-.015	.025-.075	1	2	3	4	-	-	-	-	No	1	2	3
	10, 11	High-alloy steel	H13, A2, D2, M2, T1	250-450	.004-.012	.020-.060	1	2	3	4	-	-	-	-	No	1	2	3
M	12, 13	Stainless steel (ferritic & martensitic)	410, 416, 440	350-550	.004-.010	.020-.050	-	-	2	1	-	4	3	-	Yes	-	1	2
	14	Stainless steel (austenitic)	303, 304, 316, 15-5, 17-4	250-500	.004-.008	.020-.040	-	-	2	1	-	4	3	-	Yes	-	2	1
K	15, 16	Gray cast iron	CLS. 20, 30, 45	500-900	.006-.020	.030-.100	1	2	3	4	-	-	-	-	No	3	1	2
	17-20	Nodular cast iron	60-40-18, 100-70-03	350-650	.005-.015	.025-.075	1	2	3	4	-	-	-	-	No	3	1	2
N	21-30	Aluminum	7075, 6061	1000+	.005-.025	.005-.125	2	3	4	5	-	-	-	1	Yes	-	2	1
S	31-35	High-temp alloys	Inconel, Hastelloy, Nimonic, Monel	60-110	.002-.005	.010-.025	-	-	-	-	2	3	1	-	Yes	-	1	2
	36, 37	Titanium alloys	6Al-4V, 5Al-5Mo-5V-3Cr	100-170	.004-.008	.020-.040	-	-	-	-	3	1	2	-	Yes	-	1	2
H	38, 39	Hardened steel >48	A2, O1, D2	100-200	.002-.005	.010-.025	2	1	-	-	-	-	-	-	No	1	2	-

Note: Feed and speed recommendations are starting operating parameters. They are only guidelines from which further optimization should take place. Operating parameters are influenced by many machining variables. These variables may cause for reductions in feeds and speed or dramatic increases. Additionally, DOC and WOC may need to be revised to optimize the tools performance.

13 mm (MDR Inserts) • Programming Data

DEFINITIONS

- » **DCX:** maximum cutting diameter
- » **DC:** effective cutter diameter
- » **KAPR:** cutting edge angle
- » **APMX:** maximum depth of cut
- » **REEQ:** program radius
- » **BS:** axial wiper length
- » **BS2:** radial wiper length
- » **OAL:** overall length
- » **LPR:** protruding length
- » **LF:** functional length

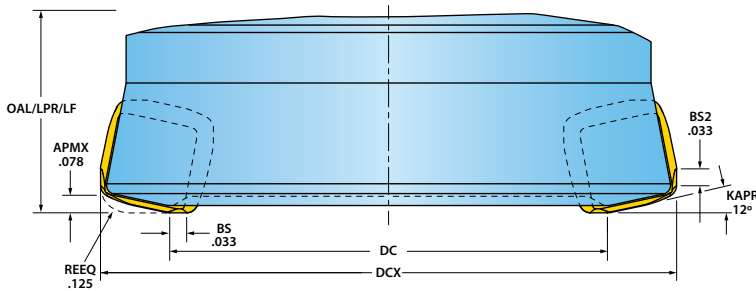

Using inserts SDES1305MDR-MR, SDES1305MDR-MR1, SDMS1305MDR-PH, & SDXS1305MDR-PH

Part Number	DCX Cutting Dia. Max.	DC Cutting Dia.	OAL Overall Length
15M1P-1202781R01	1.250	0.423	2.750
15M1P-1204759R01	1.250	0.423	4.750
15M1P-1502786R01	1.500	0.673	2.750
15M1P-1505386R01	1.500	0.673	5.340
15M1P-12017X8R01	1.250	0.423	1.750
5M5P-20R01	2.000	1.170	2.000
5M6P-20R01	2.000	1.170	2.000
5M5P-25R01	2.500	1.170	2.000
5M6P-25R01	2.500	1.170	2.000
5M5P-30R01	3.000	2.170	2.000
5M6P-30R01	3.000	2.170	2.000
5M5P-30R02	3.000	2.170	2.000
5M6P-30R02	3.000	2.170	2.000
5M5P-40R01	4.000	3.170	2.500
5M6P-40R01	4.000	3.170	2.500
5M5P-50R01	5.000	4.170	2.500
5M6P-50R01	5.000	4.170	2.500

13 mm (MDR Inserts) • Programming Tips

Using inserts SDES1305MDR-MR, SDES1305MDR-MR1, SDMS1305MDR-PH, & SDXS1305MDR-PH

- » The shape of the insert nose can be approximated by programming as-if the insert had a **.094"** corner radius (REEQ). The difference will result in an unmachined area that's approximately **.060"** deep.
- » The recommendations for cutting speed, chip-thickness grade, and insert geometry are starting recommendations and should be optimized based on the type and rate of edge failure.
- » The [Machining Calculator App](#), on Ingersoll's website, is another resource for estimating and optimizing parameters. There are additional inputs like the radial width of cut and the effective rake angle can be included into the estimates.

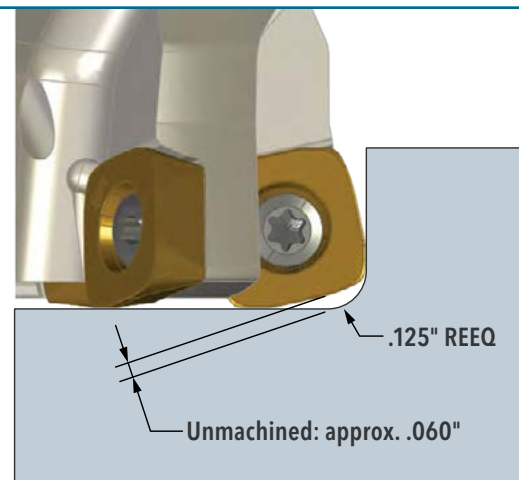

13 mm (MDR Inserts) • Straight Ramping

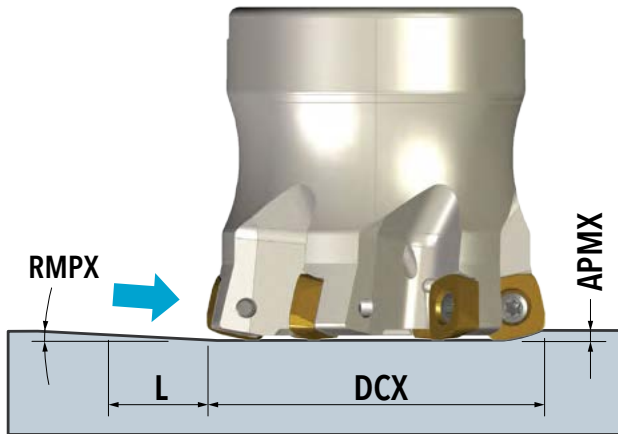

Using Inserts SDES1305MDR-MR, SDES1305MDR-MR1, SDMS1305MDR-PH, & SDXS1305MDR-PH

DCX Cutting Dia. Max.	RMPX Ramp Angle Max.	L*	APMX Depth of Cut Max.
1.250	13.10	0.344	0.078
1.500	7.10	0.631	0.078
2.000	3.90	1.147	0.078
2.500	2.70	1.656	0.078
3.000	1.60	2.794	0.078
4.000	1.10	4.063	0.078
5.000	0.80	5.587	0.078

* L in this table is the length the cutter travels to reach the maximum depth of cut (.078") while traveling at the maximum ramp angle listed for the cutter.

13 mm (MDR Inserts) • Helical Ramping

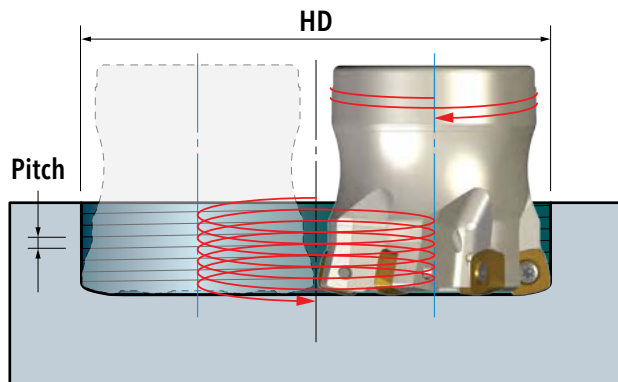

PITCH

The maximum pitch is determined to not exceed the maximum depth of cut (APMX) and to not exceed the maximum ramp angle (RMPX).

Using Inserts SDES1305MDR-MR, SDES1305MDR-MR1, SDMS1305MDR-PH, & SDXS1305MDR-PH

DCX Cutting Dia. Max.	HD Hole Dia. Min.	HD Hole Dia. Max.	HD Hole Dia. Min. w/o Cusp	HD Hole Dia. Max. w/o Cusp	Max. Pitch Per Revolution
1.250	1.502	2.500	1.607	1.673	0.078
1.500	2.000	3.000	2.107	2.173	0.078
2.000	2.996	4.000	3.104	3.170	0.078
2.500	3.996	5.000	4.102	4.170	0.078
3.000	5.002	6.000	5.105	5.171	0.078
4.000	7.002	8.000	7.102	7.170	0.078
5.000	9.002	10.000	9.104	9.170	0.078

» The table lists the maximum and minimum hole diameters (HD) for helical interpolating a hole from solid stock. For holes where a flat-bottom is required, the table includes maximum and minimum hole diameters such that no cusp is remaining at the bottom of the hole.

» The figure shows that the maximum pitch (advance for every 360° of machine travel) should not exceed .078".

13 mm (MPR Inserts) • Programming Data

DEFINITIONS

- » **DCX:** maximum cutting diameter
- » **DC:** effective cutter diameter
- » **KAPR:** cutting edge angle
- » **APMX:** maximum depth of cut
- » **REEQ:** program radius
- » **BS:** axial wiper length
- » **BS2:** radial wiper length
- » **OAL:** overall length
- » **LPR:** protruding length
- » **LF:** functional length

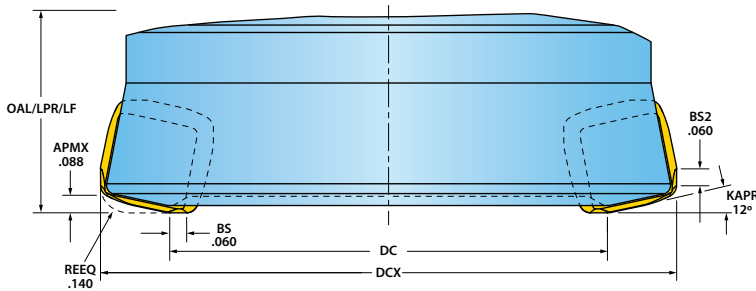

Using Inserts SDES1305MPR-MR, SDES1305MPR-MR1, SDXS1305MPR-MR, & SDXS1305MPR-MR1

Part Number	DCX Cutting Dia. Max.	DC Cutting Dia.	OAL Overall Length
15M1P-1202781R01	2.220	0.533	2.735
15M1P-1204759R01	1.220	0.533	4.735
15M1P-1502786R01	1.470	0.784	2.735
15M1P-1505386R01	1.470	0.784	5.325
15M1P-12017X8R01	1.220	0.533	1.735
5M5P-20R01	1.970	1.281	1.985
5M6P-20R01	1.970	1.281	1.985
5M5P-25R01	2.470	1.781	1.985
5M6P-25R01	2.470	1.781	1.985
5M5P-30R01	2.970	2.281	1.985
5M6P-30R01	2.970	2.281	1.985
5M5P-30R02	2.970	2.281	1.985
5M6P-30R02	2.970	2.281	1.985
5M5P-40R01	3.970	3.281	2.485
5M6P-40R01	3.970	3.281	2.485
5M5P-50R01	4.970	4.281	2.485
5M6P-50R01	4.970	4.281	2.485

13 mm (MPR Inserts) • Programming Tips

Using Inserts SDES1305MPR-MR, SDES1305MPR-MR1, SDXS1305MPR-MR, & SDXS1305MPR-MR1

- » The shape of the insert nose can be approximated by programming as-if the insert had a **.140"** corner radius (REEQ). The difference will result in an unmachined area that's approximately **.060"** deep.
- » The recommendations for cutting speed, chip-thickness grade, and insert geometry are starting recommendations and should be optimized based on the type and rate of edge failure.
- » The [Machining Calculator App](#), on Ingersoll's website, is another resource for estimating and optimizing parameters. There are additional inputs like the radial width of cut and the effective rake angle can be included into the estimates.

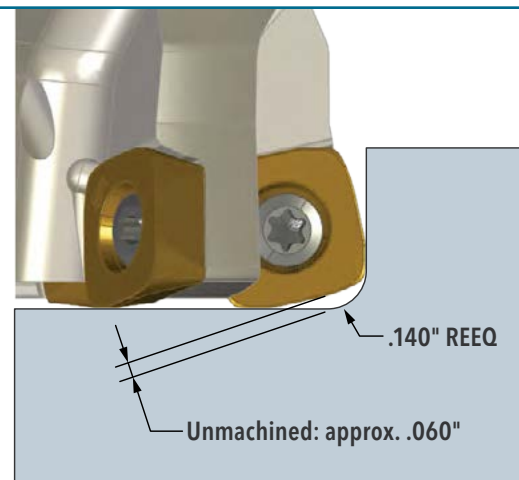

13 mm (MPR Inserts) • Straight Ramping

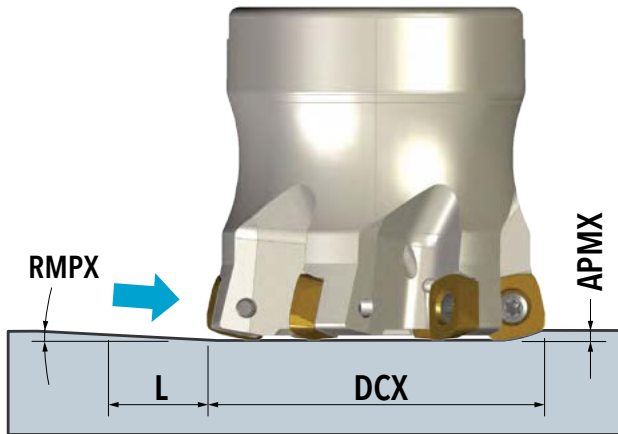

Using Inserts SDES1305MPR-MR, SDES1305MPR-MR1, SDXS1305MPR-MR, & SDXS1305MPR-MR1

DCX Cutting Dia. Max.	RMPX Ramp Angle Max.	L*	APMX Depth of Cut Max.
1.220	9.10	0.556	0.088
1.470	5.20	0.971	0.088
2.960	2.90	1.739	0.088
3.960	2.10	2.402	0.088
4.961	1.20	4.202	0.088
5.961	0.80	6.303	0.088
6.961	0.60	8.404	0.088

* L in this table is the length the cutter travels to reach the maximum depth of cut (.088") while traveling at the maximum ramp angle listed for the cutter.

13 mm (MPR Inserts) • Helical Ramping

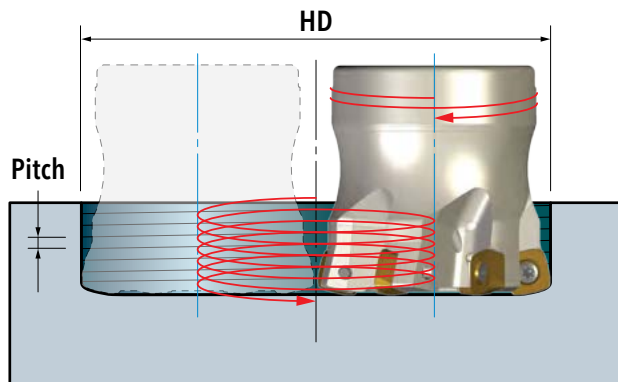

PITCH

The maximum pitch is determined to not exceed the maximum depth of cut (APMX) and to not exceed the maximum ramp angle (RMPX).

Using Inserts SDES1305MPR-MR, SDES1305MPR-MR1, SDXS1305MPR-MR, & SDXS1305MPR-MR1

DCX Cutting Dia. Max.	HD Hole Dia. Min.	HD Hole Dia. Max.	HD Hole Dia. Min. w/o Cusp	HD Hole Dia. Max. w/o Cusp	Max. Pitch Per Revolution
1.220	1.504	2.440	1.635	1.753	0.088
1.470	2.004	2.940	2.136	2.254	0.088
1.970	3.000	3.940	3.133	3.251	0.088
2.470	3.998	4.940	4.133	4.251	0.088
2.970	5.014	5.940	5.134	5.252	0.088
3.970	7.012	7.940	7.131	7.251	0.088
4.970	9.012	9.940	9.133	9.251	0.088

- » The table lists the maximum and minimum hole diameters (HD) for helical interpolating a hole from solid stock. For holes where a flat-bottom is required, the table includes maximum and minimum hole diameters such that no cusp is remaining at the bottom of the hole.
- » The figure shows that the maximum pitch (advance for every 360° of machine travel) should not exceed .088".

16 mm • Operating Guidelines

AXIAL CHIP THINNING

NOTE: The operating guidelines table below includes a column for feed-per-tooth (fz). That column accounts for the axial chip thinning that's generated by the cutting-edge angle (lead angle). All GoldSFeed high-feed cutters have a 12° cutting edge angle resulting in an fz that is approximately 5x the recommended chip thickness (hex).

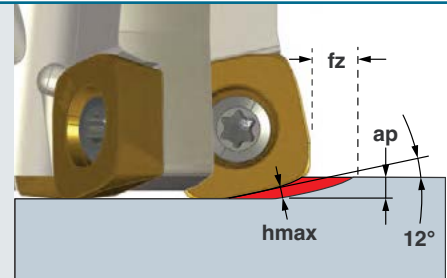

ISO	Materials			Vc Cutting Speed SFM	Hex Max. Chip Thickness (inch)	fz* Feed/ Tooth (inch)	Harder «-----» Tougher								Coolant	Geometry			
	Mat'l Group #VDI 3323	Type	Examples				IN4015	IN2515	IN4005	IN2505	IN4030	IN2530	IN7035	IN4035		IN2535	MR	MR1	MM
P	1-5	Non-alloy steel	1018, A36, 1045, A572, 1070	400-600	.008-.022	.040-.110	-	-	1	2	3	4	-	-	-	No	1	2	3
	6-9	Low-alloy steel	4140, 4340, P20, 8620, 300M	300-500	.008-.018	.040-.090	-	-	1	2	3	4	-	-	-	No	1	2	3
	10, 11	High-alloy steel	H13, A2, D2, M2, T1	200-400	.008-.015	.040-.075	-	-	1	2	3	4	-	-	-	No	1	2	3
M	12, 13	Stainless steel (ferritic & martensitic)	410, 416, 440	200-400	.006-.012	.030-.060	-	-	-	-	4	3	-	2	1	Yes	-	1	2
	14	Stainless steel (austenitic)	303, 304, 316, 15-5, 17-4	300-500	.004-.008	.020-.040	-	-	-	-	4	3	-	2	1	Yes	-	2	1
K	15, 16	Gray cast iron	CLS. 20, 30, 45	500-900	.004-.025	.020-.125	1	2	3	4	-	-	-	-	-	No	3	1	2
	17-20	Nodular cast iron	60-40-18, 100-70-03	300-700	.004-.020	.020-.100	1	2	3	4	-	-	-	-	-	No	3	1	2
N	21-30	Aluminum	7075, 6061	1000+	.004-.025	.020-.125	1	2	3	4	-	-	-	-	-	Yes	-	2	1
S	31-35	High-temp alloys	Inconel, Hastelloy, Nimonic, Monel	50-100	.002-.005	.010-.025	-	-	-	-	-	4	3	2	1	Yes	-	1	2
	36, 37	Titanium alloys	6Al-4V, 5Al-5Mo-5V-3Cr	90-150	.004-.008	.020-.040	-	-	-	-	-	4	3	2	1	Yes	-	1	2
H	38, 39	Hardened steel >48	A2, O1, D2	100-200	.003-.005	.015-.025	-	-	1	2	-	-	-	-	-	No	1	-	-

Note: Feed and speed recommendations are starting operating parameters. They are only guidelines from which further optimization should take place. Operating parameters are influenced by many machining variables. These variables may cause for reductions in feeds and speed or dramatic increases. Additionally, DOC and WOC may need to be revised to optimize the tools performance.

16 mm • Programming Data

DEFINITIONS

- » **DCX:** maximum cutting diameter
- » **DC:** effective cutter diameter
- » **KAPR:** cutting edge angle
- » **APMX:** maximum depth of cut
- » **REEQ:** program radius
- » **BS:** axial wiper length
- » **BS2:** radial wiper length

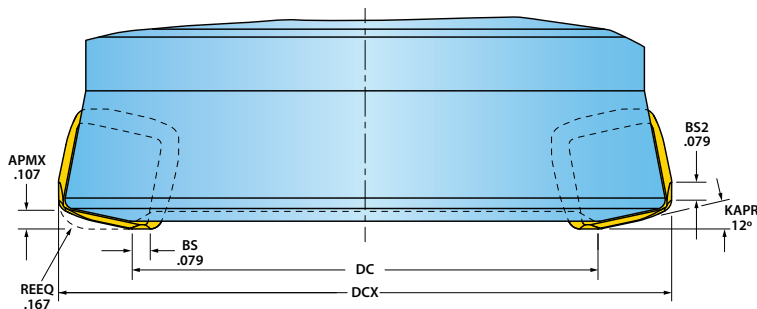

Part Number	DCX Cutting Dia. Max.	DC Cutting Dia.
5G5Q-25R01	2.500	1.645
5G5Q-25R02	2.500	1.645
5G5Q-30R01	3.000	2.144
5G6Q-30R01	3.000	2.144
5G5Q-30R02	3.000	2.144
5G5Q-40R01	4.000	3.144
5G6Q-40R01	4.000	3.144
5G6Q-50R01	5.000	4.144
5G6Q-60R01	6.000	5.144

16 mm • Programming Tips

- » The shape of the insert nose can be approximated by programming as-if the insert had a **.167"** corner radius (REEQ). The difference will result in an unmachined area that's approximately **.056"** deep.
- » The recommendations for cutting speed, chip-thickness grade, and insert geometry are starting recommendations and should be optimized based on the type and rate of edge failure.
- » The [Machining Calculator App](#), on Ingersoll's website, is another resource for estimating and optimizing parameters. There are additional inputs like the radial width of cut and the effective rake angle can be included into the estimates.

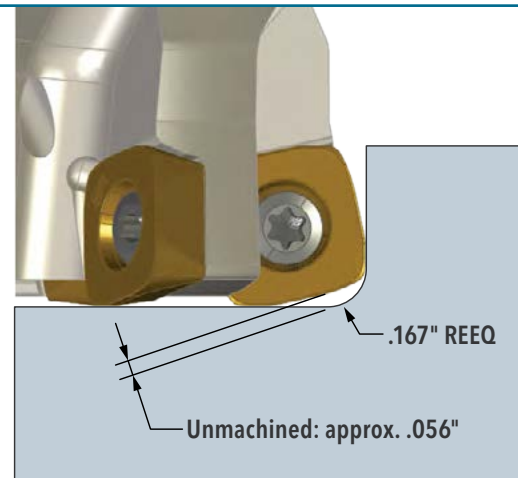

16 mm • Straight Ramping

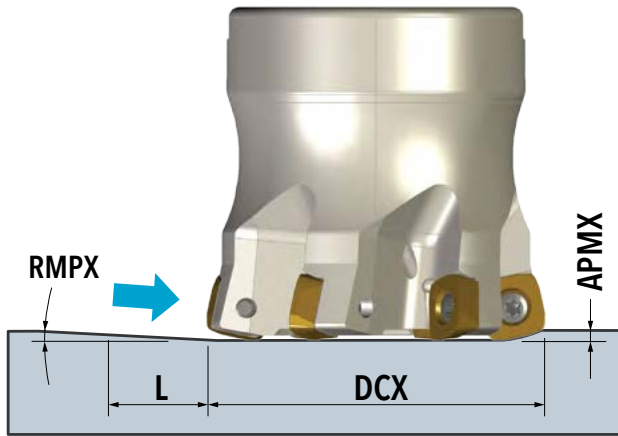

DCX Cutting Dia. Max.	RMPX Ramp Angle Max.	L*	APMX Depth of Cut Max.
2.500	3.3	1.856	0.107
3.000	2.4	2.553	0.107
4.000	1.6	3.831	0.107
5.000	1.2	5.108	0.107
6.000	0.9	6.811	0.107

* L in this table is the length the cutter travels to reach the maximum depth of cut (.107") while traveling at the maximum ramp angle listed for the cutter.

16 mm • Helical Ramping

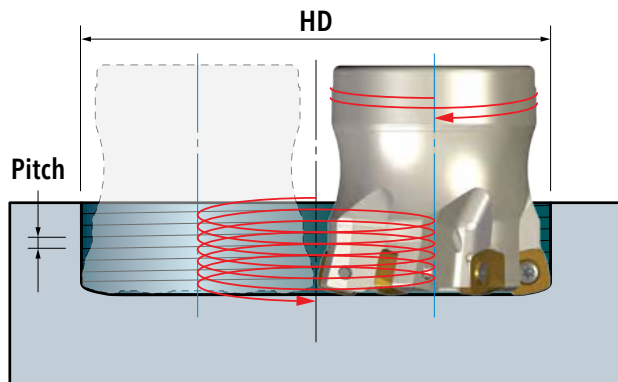

PITCH

The maximum pitch is determined to not exceed the maximum depth of cut (APMX) and to not exceed the maximum ramp angle (RMPX).

DCX Cutting Dia. Max.	HD Hole Dia. Min.	HD Hole Dia. Max.	HD Hole Dia. Max. w/o Cusp	Max. Pitch Per Revolution
2.500	3.822	5.000	4.145	0.107
3.000	4.822	6.000	5.144	0.107
4.000	6.822	8.000	7.144	0.107
5.000	8.824	10.000	9.144	0.107
6.000	10.824	12.000	11.144	0.107

EXAMPLE

- » The minimum hole diameter that the **2.500"** diameter cutter can interpolate from solid is **3.822"** (leaving a raised cusp).
- » The maximum hole diameter that the **2.500"** diameter cutter can interpolate from solid is **5.000"**.
- » The maximum hole diameter that the **2.500"** diameter cutter can interpolate from solid while leaving a flat-bottom is **4.145"** (leaving no raised cusp).
- » The maximum pitch for this series matches the insert's radial wiper length of **.107"**.

19 mm • Operating Guidelines

AXIAL CHIP THINNING

NOTE: The operating guidelines table below includes a column for feed-per-tooth (fz). That column accounts for the axial chip thinning that's generated by the cutting-edge angle (lead angle). All GoldSFeed high-feed cutters have a 12° cutting edge angle resulting in an fz that is approximately 5x the recommended chip thickness (hex).

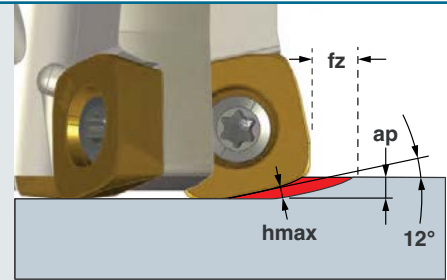

ISO	Materials			Vc Cutting Speed SFM	Hex Max. Chip Thickness (inch)	fz* Feed/ Tooth (inch)	Harder «----» Tougher								Coolant	Geometry		
	Mat'l Group #VDI 3323	Type	Examples				IN4005	IN2505	IN4030	IN2530	IN4035	IN2535	IN05S	MR		MR1	PH	
P	1-5	Non-alloy steel	1018, A36, 1045, A572, 1070	300-600	.008-.025	.040-.125	1	2	3	4	-	-	-	No	1	2	3	
	6-9	Low-alloy steel	4140, 4340, P20, 8620, 300M	250-500	.008-.020	.040-.100	1	2	3	4	-	-	-	No	1	2	3	
	10, 11	High-alloy steel	H13, A2, D2, M2, T1	200-400	.008-.016	.040-.080	1	2	3	4	-	-	-	No	1	2	3	
M	12, 13	Stainless steel (ferritic & martensitic)	410, 416, 440	200-400	.006-.014	.030-.070	-	-	4	3	2	1	-	Yes	-	1	2	
	14	Stainless steel (austenitic)	303, 304, 316, 15-5, 17-4	300-500	.004-.008	.020-.040	-	-	4	3	2	1	-	Yes	-	2	1	
K	15, 16	Gray cast iron	CLS. 20, 30, 45	500-900	.004-.025	.020-.125	1	2	3	4	-	-	-	No	3	1	2	
	17-20	Nodular cast iron	60-40-18, 100-70-03	300-700	.004-.020	.020-.100	1	2	3	4	-	-	-	No	3	1	2	
N	21-30	Aluminum	7075, 6061	1000+	.004-.025	.020-.125	2	3	4	5	-	-	1	Yes	-	2	1	
S	31-35	High-temp alloys	Inconel, Hastelloy, Nimonic, Monel	50-100	.002-.005	.010-.025	-	-	4	3	2	1	-	Yes	-	1	2	
	36, 37	Titanium alloys	6Al-4V, 5Al-5Mo-5V-3Cr	90-150	.004-.008	.020-.040	-	-	4	3	2	1	-	Yes	-	1	2	
H	38, 39	Hardened steel >48	A2, O1, D2	100-200	.003-.005	.015-.025	2	1	-	-	-	-	-	No	1	-	-	

Note: Feed and speed recommendations are starting operating parameters. They are only guidelines from which further optimization should take place. Operating parameters are influenced by many machining variables. These variables may cause for reductions in feeds and speed or dramatic increases. Additionally, DOC and WOC may need to be revised to optimize the tools performance.

19 mm (MDR Inserts) • Programming Data

DEFINITIONS

- » **DCX:** maximum cutting diameter
- » **DC:** effective cutter diameter
- » **KAPR:** cutting edge angle
- » **APMX:** maximum depth of cut
- » **REEQ:** program radius
- » **BS:** axial wiper length
- » **BS2:** radial wiper length
- » **OAL:** overall length

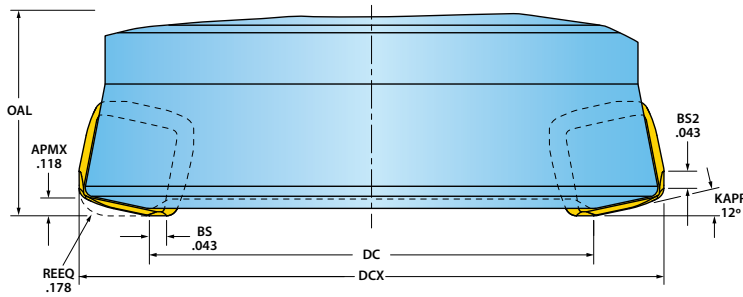

Using Inserts SDES1906MDR-MR, SDMS1906MDR-PH

Part Number	DCX Cutting Dia. Max.	DC Cutting Dia.	OAL Overall Length
5G5M-30R01	3.000	1.766	2.000
5G6M-30R01	3.000	1.755	2.000
5G5M-40R01	4.000	2.769	2.500
5G6M-40R01	4.000	2.755	2.500
5G5M-50R01	5.000	3.759	2.500
5G6M-50R01	5.000	3.755	2.500
5G5M-60R01	6.000	4.757	2.500
5G6M-60R01	6.000	4.755	2.500
5G6M-70R01	7.000	5.755	2.500

19 mm (MDR Inserts) • Programming Tips

Using Inserts SDES1906MDR-MR, SDMS1906MDR-PH

- » The shape of the insert nose can be approximated by programming as-if the insert had a **.178"** corner radius (REEQ). The difference will result in an unmachined area that's approximately **.094"** deep.
- » The recommendations for cutting speed, chip-thickness grade, and insert geometry are starting recommendations and should be optimized based on the type and rate of edge failure.
- » The **Machining Calculator App**, on Ingersoll's website, is another resource for estimating and optimizing parameters. There are additional inputs like the radial width of cut and the effective rake angle can be included into the estimates.

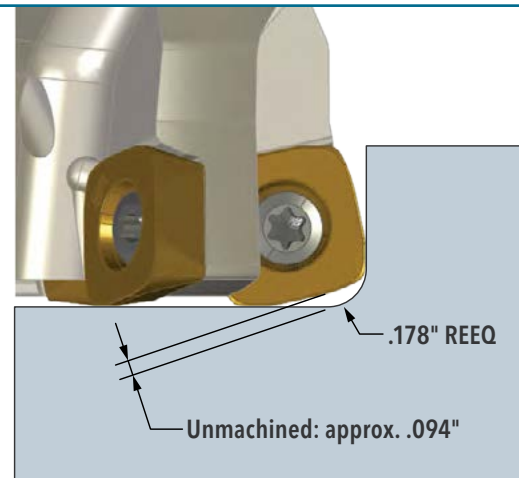

19 mm (MDR Inserts) • Straight Ramping

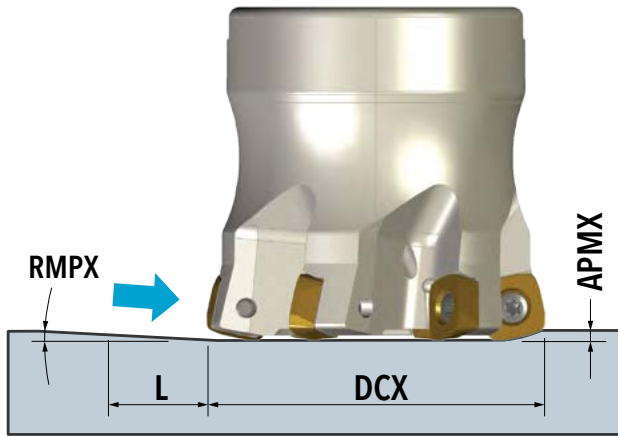

Using Inserts SDES1906MDR-MR, SDMS1906MDR-PH

DCX Cutting Dia. Max.	RMPX Ramp Angle Max.	L*	APMX Depth of Cut Max.
3.000	2.70	2.505	0.118
4.000	1.70	3.978	0.118
5.000	1.70	3.978	0.118
6.000	1.30	5.201	0.118
7.000	1.02	6.629	0.118

* L in this table is the length the cutter travels to reach the maximum depth of cut (.118") while traveling at the maximum ramp angle listed for the cutter.

19 mm (MDR Inserts) • Helical Ramping

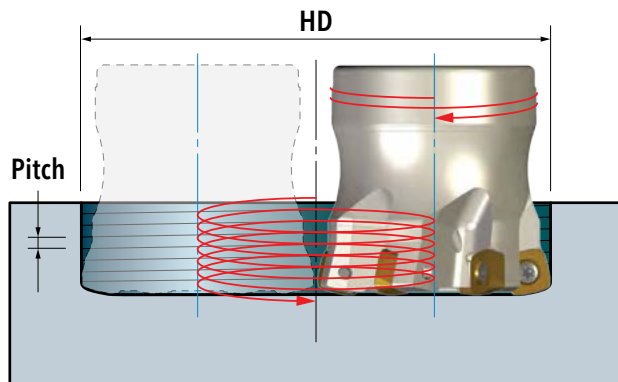

Using Inserts SDES1906MDR-MR, SDMS1906MDR-PH

DCX Cutting Dia. Max.	HD Hole Dia. Min.	HD Hole Dia. Max.	HD Hole Dia. Max. w/o Cusp	Max. Pitch Per Revolution
3.000	4.518	6.000	4.766	0.118
4.000	6.520	8.000	6.769	0.118
5.000	8.520	10.000	8.759	0.118
6.000	10.520	12.000	10.757	0.118
7.000	12.521	14.000	12.755	0.118

PITCH

The maximum pitch is determined to not exceed the maximum depth of cut (APMX) and to not exceed the maximum ramp angle (RMPX).

EXAMPLE

- » The minimum hole diameter that the **3.000"** diameter cutter can interpolate from solid is **4.518"** (leaving a raised cusp).
- » The maximum hole diameter that the **3.000"** diameter cutter can interpolate from solid is **6.000"** (leaving a raised cusp).
- » The maximum hole diameter that the **3.000"** diameter cutter can interpolate from solid while leaving a flat-bottom is **4.766"** (leaving no raised cusp).

19 mm (MPR Inserts) • Programming Data

DEFINITIONS

- » **DCX:** maximum cutting diameter
- » **DC:** effective cutter diameter
- » **KAPR:** cutting edge angle
- » **APMX:** maximum depth of cut
- » **REEQ:** program radius
- » **BS:** axial wiper length
- » **BS2:** radial wiper length
- » **OAL:** overall length

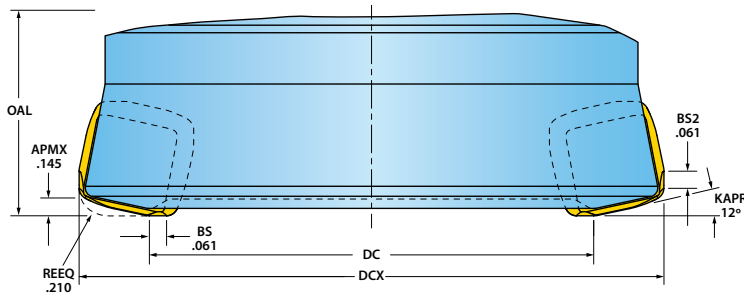

Using Inserts SDES1906MPR-MR, SDES1906MPR-MR1, SDXS1906MPR-MR, & SDXS1906MPR-MR1

Part Number	DCX Cutting Dia. Max.	DC Cutting Dia.	OAL Overall Length
5G5M-30R01	2.960	1.903	1.981
5G6M-30R01	2.960	1.894	1.981
5G5M-40R01	3.960	2.906	2.481
5G6M-40R01	3.960	2.894	2.481
5G5M-50R01	4.961	3.897	2.481
5G6M-50R01	4.961	3.894	2.481
5G5M-60R01	5.961	4.896	2.481
5G6M-60R01	5.961	4.894	2.481
5G6M-70R01	6.961	5.894	2.481

19 mm (MPR Inserts) • Programming Tips

Using Inserts SDES1906MPR-MR, SDES1906MPR-MR1, SDXS1906MPR-MR, & SDXS1906MPR-MR1

- » The shape of the insert nose can be approximated by programming as-if the insert had a **.212"** corner radius (REEQ). The difference will result in an unmachined area that's approximately **.068"** deep.
- » The recommendations for cutting speed, chip-thickness grade, and insert geometry are starting recommendations and should be optimized based on the type and rate of edge failure.
- » The [Machining Calculator App](#), on Ingersoll's website, is another resource for estimating and optimizing parameters. There are additional inputs like the radial width of cut and the effective rake angle can be included into the estimates.

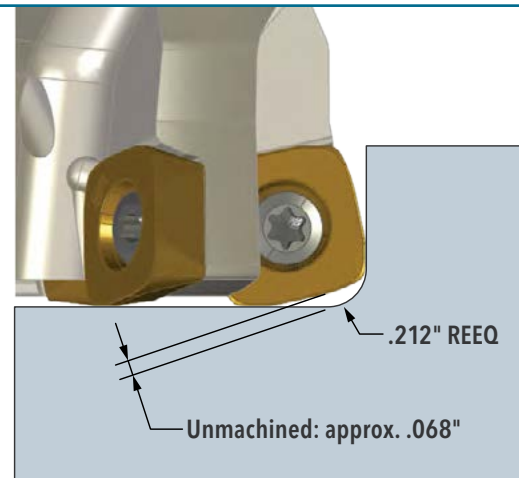

19 mm (MPR Inserts) • Straight Ramping

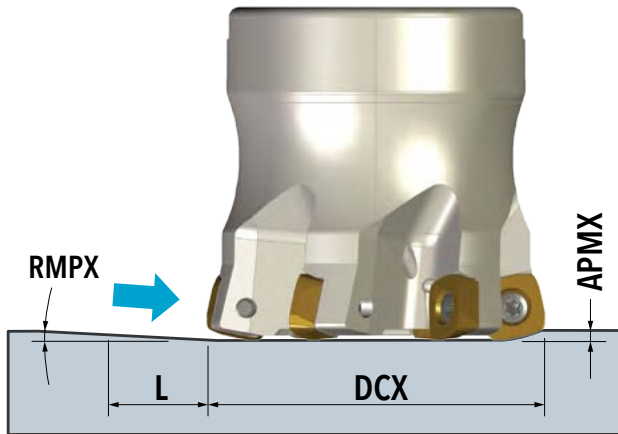

Using Inserts SDES1906MPR-MR, SDES1906MPR-MR1, SDXS1906MPR-MR, & SDXS1906MPR-MR1

DCX Cutting Dia. Max.	RMPX Ramp Angle Max.	L*	APMX Depth of Cut Max.
2.960	1.90	4.373	0.145
3.960	1.20	6.924	0.145
4.961	1.40	5.935	0.145
5.961	1.10	7.553	0.145
6.961	1.02	8.145	0.145

* L in this table is the length the cutter travels to reach the maximum depth of cut (.145") while traveling at the maximum ramp angle listed for the cutter.

19 mm (MPR Inserts) • Helical Ramping

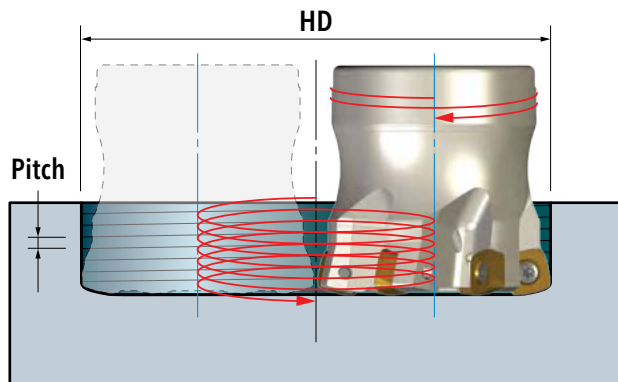

Using Inserts SDES1906MPR-MR, SDES1906MPR-MR1, SDXS1906MPR-MR, & SDXS1906MPR-MR1

DCX Cutting Dia. Max.	HD Hole Dia. Min.	HD Hole Dia. Max.	HD Hole Dia. Max. w/o Cusp	Max. Pitch Per Revolution
2.960	4.526	5.920	4.863	0.145
3.960	6.528	7.920	6.866	0.145
4.961	8.528	9.922	8.858	0.145
5.961	10.528	11.922	10.857	0.145
6.961	12.530	13.922	12.895	0.145

PITCH

The maximum pitch is determined to not exceed the maximum depth of cut (APMX) and to not exceed the maximum ramp angle (RMPX).

EXAMPLE

- » The minimum hole diameter that the **2.960"** diameter cutter can interpolate from solid is **4.526"** (leaving a raised cusp).
- » The maximum hole diameter that the **2.960"** diameter cutter can interpolate from solid is **5.920"** (leaving a raised cusp).
- » The maximum hole diameter that the **2.960"** diameter cutter can interpolate from solid while leaving a flat-bottom is **4.863"** (leaving no raised cusp).