

13 mm (MDR Inserts) • Programming Data

DEFINITIONS

- » **DCX:** maximum cutting diameter
- » **DC:** effective cutter diameter
- » **KAPR:** cutting edge angle
- » **APMX:** maximum depth of cut
- » **REEQ:** program radius
- » **BS:** axial wiper length
- » **BS2:** radial wiper length
- » **OAL:** overall length
- » **LPR:** protruding length
- » **LF:** functional length

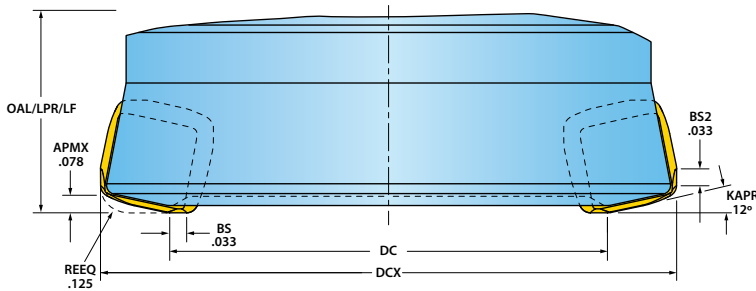

Using inserts SDES1305MDR-MR, SDES1305MDR-MR1, SDMS1305MDR-PH, & SDXS1305MDR-PH

Part Number	DCX Cutting Dia. Max.	DC Cutting Dia.	OAL Overall Length
15M1P-1202781R01	1.250	0.423	2.750
15M1P-1204759R01	1.250	0.423	4.750
15M1P-1502786R01	1.500	0.673	2.750
15M1P-1505386R01	1.500	0.673	5.340
15M1P-12017X8R01	1.250	0.423	1.750
5M5P-20R01	2.000	1.170	2.000
5M6P-20R01	2.000	1.170	2.000
5M5P-25R01	2.500	1.170	2.000
5M6P-25R01	2.500	1.170	2.000
5M5P-30R01	3.000	2.170	2.000
5M6P-30R01	3.000	2.170	2.000
5M5P-30R02	3.000	2.170	2.000
5M6P-30R02	3.000	2.170	2.000
5M5P-40R01	4.000	3.170	2.500
5M6P-40R01	4.000	3.170	2.500
5M5P-50R01	5.000	4.170	2.500
5M6P-50R01	5.000	4.170	2.500

13 mm (MDR Inserts) • Programming Tips

Using inserts SDES1305MDR-MR, SDES1305MDR-MR1, SDMS1305MDR-PH, & SDXS1305MDR-PH

- » The shape of the insert nose can be approximated by programming as-if the insert had a **.094"** corner radius (REEQ). The difference will result in an unmachined area that's approximately **.060"** deep.
- » The recommendations for cutting speed, chip-thickness grade, and insert geometry are starting recommendations and should be optimized based on the type and rate of edge failure.
- » The [Machining Calculator App](#), on Ingersoll's website, is another resource for estimating and optimizing parameters. There are additional inputs like the radial width of cut and the effective rake angle can be included into the estimates.

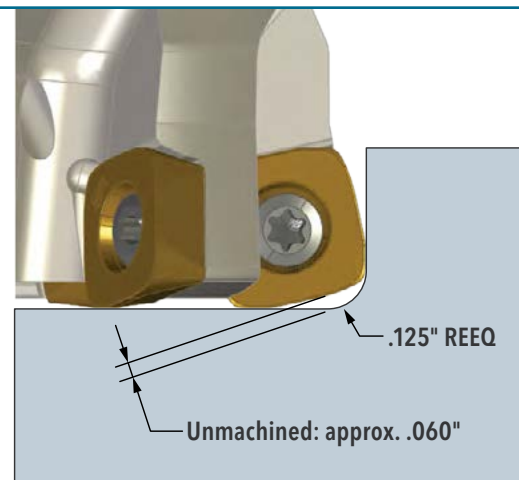

13 mm (MPR Inserts) • Programming Data

DEFINITIONS

- » **DCX:** maximum cutting diameter
- » **DC:** effective cutter diameter
- » **KAPR:** cutting edge angle
- » **APMX:** maximum depth of cut
- » **REEQ:** program radius
- » **BS:** axial wiper length
- » **BS2:** radial wiper length
- » **OAL:** overall length
- » **LPR:** protruding length
- » **LF:** functional length

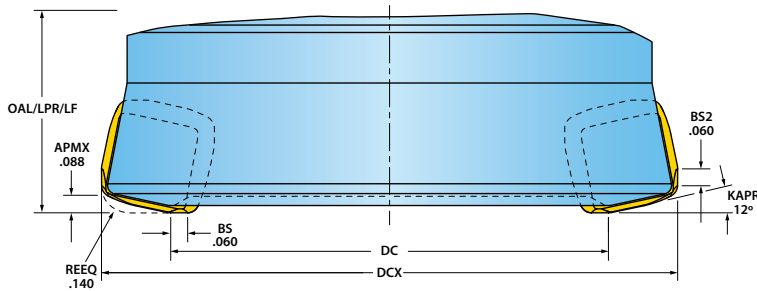

Using Inserts SDES1305MPR-MR, SDES1305MPR-MR1, SDXS1305MPR-MR, & SDXS1305MPR-MR1

Part Number	DCX Cutting Dia. Max.	DC Cutting Dia.	OAL Overall Length
15M1P-1202781R01	2.220	0.533	2.735
15M1P-1204759R01	1.220	0.533	4.735
15M1P-1502786R01	1.470	0.784	2.735
15M1P-1505386R01	1.470	0.784	5.325
15M1P-12017X8R01	1.220	0.533	1.735
5M5P-20R01	1.970	1.281	1.985
5M6P-20R01	1.970	1.281	1.985
5M5P-25R01	2.470	1.781	1.985
5M6P-25R01	2.470	1.781	1.985
5M5P-30R01	2.970	2.281	1.985
5M6P-30R01	2.970	2.281	1.985
5M5P-30R02	2.970	2.281	1.985
5M6P-30R02	2.970	2.281	1.985
5M5P-40R01	3.970	3.281	2.485
5M6P-40R01	3.970	3.281	2.485
5M5P-50R01	4.970	4.281	2.485
5M6P-50R01	4.970	4.281	2.485

13 mm (MPR Inserts) • Programming Tips

Using Inserts SDES1305MPR-MR, SDES1305MPR-MR1, SDXS1305MPR-MR, & SDXS1305MPR-MR1

- » The shape of the insert nose can be approximated by programming as-if the insert had a **.140"** corner radius (REEQ). The difference will result in an unmachined area that's approximately **.060"** deep.
- » The recommendations for cutting speed, chip-thickness grade, and insert geometry are starting recommendations and should be optimized based on the type and rate of edge failure.
- » The [Machining Calculator App](#), on Ingersoll's website, is another resource for estimating and optimizing parameters. There are additional inputs like the radial width of cut and the effective rake angle can be included into the estimates.

