

19 mm (MDR Inserts) • Programming Data

DEFINITIONS

- » **DCX:** maximum cutting diameter
- » **DC:** effective cutter diameter
- » **KAPR:** cutting edge angle
- » **APMX:** maximum depth of cut
- » **REEQ:** program radius
- » **BS:** axial wiper length
- » **BS2:** radial wiper length
- » **OAL:** overall length

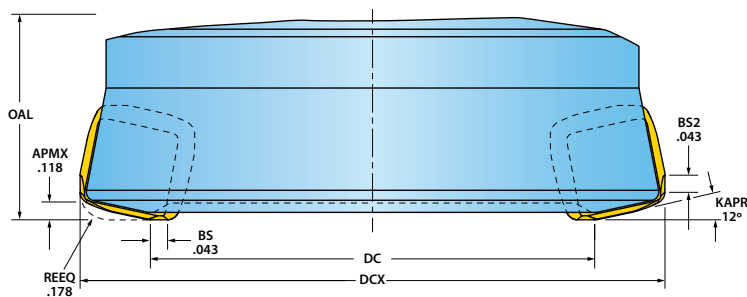

Using Inserts SDES1906MDR-MR, SDMS1906MDR-PH

Part Number	DCX Cutting Dia. Max.	DC Cutting Dia.	OAL Overall Length
5G5M-30R01	3.000	1.766	2.000
5G6M-30R01	3.000	1.755	2.000
5G5M-40R01	4.000	2.769	2.500
5G6M-40R01	4.000	2.755	2.500
5G5M-50R01	5.000	3.759	2.500
5G6M-50R01	5.000	3.755	2.500
5G5M-60R01	6.000	4.757	2.500
5G6M-60R01	6.000	4.755	2.500
5G6M-70R01	7.000	5.755	2.500

19 mm (MDR Inserts) • Programming Tips

Using Inserts SDES1906MDR-MR, SDMS1906MDR-PH

- » The shape of the insert nose can be approximated by programming as-if the insert had a **.178"** corner radius (REEQ). The difference will result in an unmachined area that's approximately **.094"** deep.
- » The recommendations for cutting speed, chip-thickness grade, and insert geometry are starting recommendations and should be optimized based on the type and rate of edge failure.
- » The **Machining Calculator App**, on Ingersoll's website, is another resource for estimating and optimizing parameters. There are additional inputs like the radial width of cut and the effective rake angle can be included into the estimates.

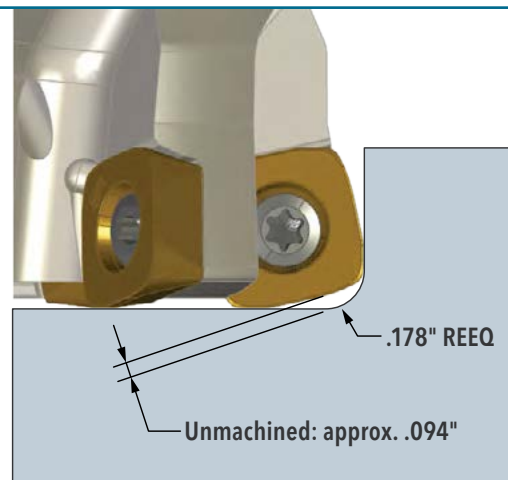

19 mm (MPR Inserts) • Programming Data

DEFINITIONS

- » **DCX:** maximum cutting diameter
- » **DC:** effective cutter diameter
- » **KAPR:** cutting edge angle
- » **APMX:** maximum depth of cut
- » **REEQ:** program radius
- » **BS:** axial wiper length
- » **BS2:** radial wiper length
- » **OAL:** overall length

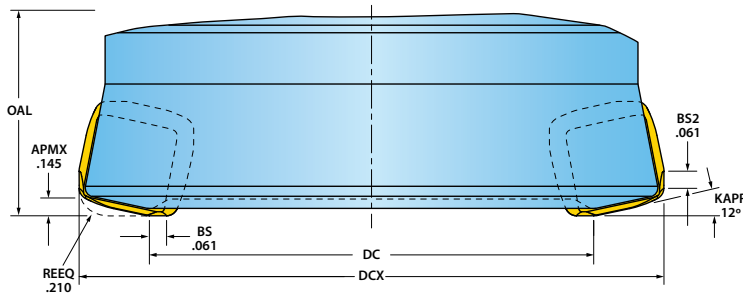

Using Inserts SDES1906MPR-MR, SDES1906MPR-MR1, SDXS1906MPR-MR, & SDXS1906MPR-MR1

Part Number	DCX Cutting Dia. Max.	DC Cutting Dia.	OAL Overall Length
5G5M-30R01	2.960	1.903	1.981
5G6M-30R01	2.960	1.894	1.981
5G5M-40R01	3.960	2.906	2.481
5G6M-40R01	3.960	2.894	2.481
5G5M-50R01	4.961	3.897	2.481
5G6M-50R01	4.961	3.894	2.481
5G5M-60R01	5.961	4.896	2.481
5G6M-60R01	5.961	4.894	2.481
5G6M-70R01	6.961	5.894	2.481

19 mm (MPR Inserts) • Programming Tips

Using Inserts SDES1906MPR-MR, SDES1906MPR-MR1, SDXS1906MPR-MR, & SDXS1906MPR-MR1

- » The shape of the insert nose can be approximated by programming as-if the insert had a **.212"** corner radius (REEQ). The difference will result in an unmachined area that's approximately **.068"** deep.
- » The recommendations for cutting speed, chip-thickness grade, and insert geometry are starting recommendations and should be optimized based on the type and rate of edge failure.
- » The [Machining Calculator App](#), on Ingersoll's website, is another resource for estimating and optimizing parameters. There are additional inputs like the radial width of cut and the effective rake angle can be included into the estimates.

