

DIPOSTRIO™ 04 RAMPING DATA

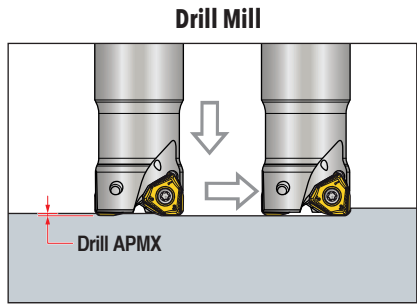
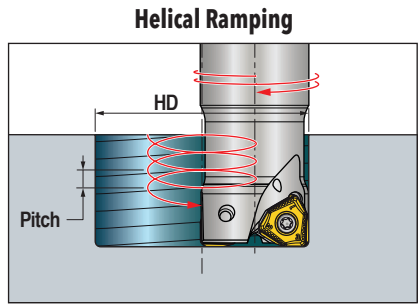
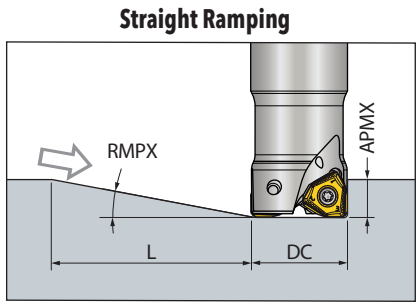

DC Cutter Diameter	Straight Ramp			Helical Ramp			Drill Mill
	RMPX Ramp Angle Max.	APMX Depth of Cut Max.	L Ramp Length Min.	HD Hole Dia. Min.	HD Hole Dia. Max.	Pitch Max.	Drill APMX Depth of Cut Max.
16	3.0	5.80	110.7	24.10		1.300	0.50
					31.20	2.500	
20	2.4	5.80	138.4	31.70		1.500	0.50
					39.20	2.500	
25	1.9	5.80	174.8	41.40		1.700	0.60
					49.20	2.500	
32	1.5	5.80	221.5	55.20		1.900	0.60
					63.20	2.600	
35	1.7	5.80	195.4	60.50		2.400	0.80
					69.20	3.200	
40	2.1	5.80	158.2	69.30		3.400	1.20
					79.20	3.800	
50	2.5	5.80	132.8	87.20		3.800	1.90
					99.20	3.800	
63	2.4	5.80	138.4	111.5		3.8	2.30
					125.2	3.8	