

DIPOSTRIO™ 06 RAMPING DATA

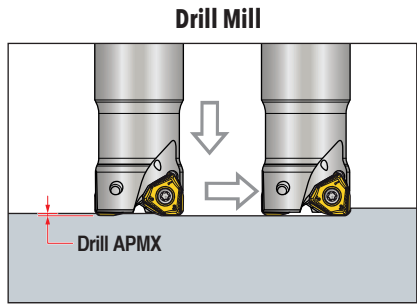
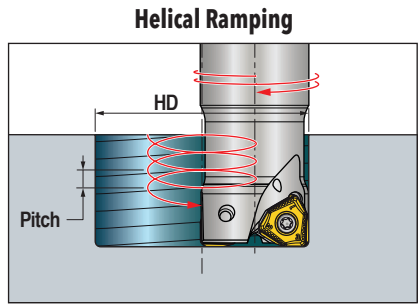
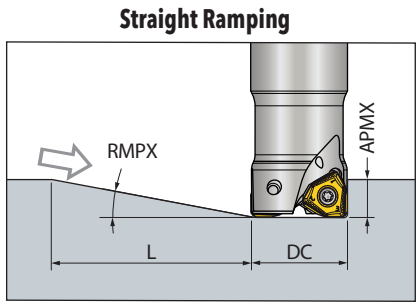

| DC Cutter Diameter | Straight Ramp | | | Helical Ramp | | | Drill Mill |
|--------------------------|-------------------------|---------------------------|-----------------------|----------------------|----------------------|---------------|---------------------------------|
| | RMPX Ramp Angle Max. | APMX Depth of Cut Max. | L Ramp Length Min. | HD Hole Dia. Min. | HD Hole Dia. Max. | Pitch Max. | Drill APMX Depth of Cut Max. |
| 1.000 | 2.7 | 0.23 | 4.8 | 1.54 | | 0.079 | 0.035 |
| | | | | | 2.00 | 0.148 | |
| 1.250 | 2.0 | 0.23 | 6.5 | 2.04 | | 0.086 | 0.035 |
| | | | | | 2.50 | 0.136 | |
| 1.500 | 1.6 | 0.23 | 8.2 | 2.54 | | 0.090 | 0.034 |
| | | | | | 3.00 | 0.131 | |
| 2.000 | 1.4 | 0.23 | 9.4 | 3.48 | | 0.113 | 0.044 |
| | | | | | 4.00 | 0.153 | |
| 2.500 | 1.8 | 0.23 | 7.3 | 4.40 | | 0.188 | 0.068 |
| | | | | | 5.00 | 0.230 | |
| 3.000 | 2.1 | 0.23 | 6.2 | 5.30 | | 0.230 | 0.100 |
| | | | | | 6.00 | 0.230 | |
| 4.000 | 2.2 | 0.23 | 5.9 | 7.15 | | 0.230 | 0.137 |
| | | | | | 8.00 | 0.230 | |
| 5.000 | 1.3 | 0.23 | 10.1 | 9.09 | | 0.230 | 0.110 |
| | | | | | 10.00 | 0.230 | |