

HI-POS HI-FEED OPERATING GUIDELINES

Radius (Lead Angle) Chip Thinning

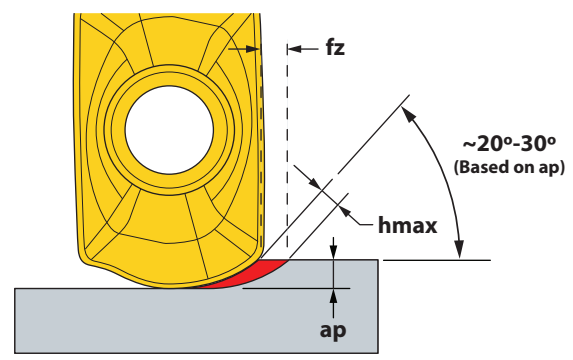

ISO	Materials			Vc Cutting Speed SFM	fz Feed/Tooth (inch)	ap Recom- mended (inch)	hmax* Max. Chip Thickness (inch)	Harder <--> Tougher				Coolant
	Mat'l Group #VDI 3323	Type	Examples					IN2504	IN2505	IN2530	IN2036	
P	1 - 5	Non-alloy Steel	1018, A36, 1045, A572, 1070	400-1000	.012-.030	.008-.019	.003-.010	3	2	1		No
	6 - 9	Low-alloy Steel	4140, 4340, P20, 8620, 300M	350-700								
	10 - 11	High-alloy Steel	H13, A2, D2, M2, T1	300-600								
M	12 - 13	Stainless Steel (Fer- ritic & Martensitic)	410, 416, 440	350-600	.012-.030	.008-.019	.003-.010		3	2	1	Yes May not be required at high speeds
	14	Stainless Steel (Austenitic)	303, 304, 316, 15-5, 17-4	300-550								
K	15 - 16	Gray Cast Iron	CLS. 20, 30, 45	500-1000	.015-.030	.008-.019	.003-.012	1	2			No
	17 - 20	Nodular Cast Iron	60-40-18, 100-70-03	400-800								
S	31 - 35	High-Temp Alloys	Inconel, Hastelloy, Nimonic, Monel	65-150	.012-.025	.008-.019	.003-.009		2	3	1	Yes
	36 - 37	Titanium Alloys	6Al-4V, 5Al-5Mo-5V-3Cr	85-200								
H	38 - 39	Hardened Steel >48	A2, O1, D2	130-250	.012-.025	.008-.015	.003-.009	1	2			No

Note: Feed and speed recommendations are starting operating parameters. They are only guidelines from which further optimization should take place. Operating parameters are influenced by many machining variables. These variables may cause for reductions in feeds and speed or dramatic increases. Additionally, DOC and WOC may need to be revised to optimize the tools performance.