

CHIPSURFER™ OPERATING GUIDELINES: 45D • DRILL MILL

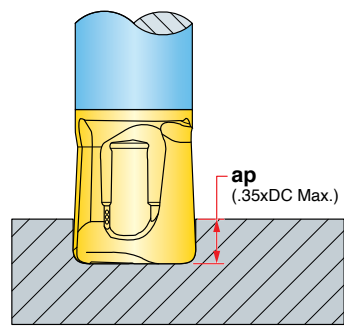

When drilling, depth of cut (ap) should not exceed .35 x DC.

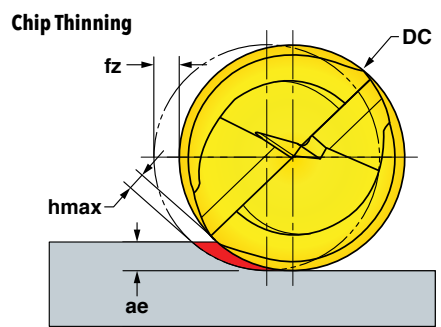

When ae is less than 25% DC, recommend use of Chip Thinning Calculator to ensure hmax is within fz range.

ISO	Materials			Mill Vc Cutting Speed SFM	Drill Vc Cutting Speed SFM	DC Cutting Dia. (inch)	fz* Feed/Tooth (inch)	Coolant
	Mat'l Group #VDI 3323	Type	Examples					
P	1 - 5	Non-alloy Steel	1018, A36, 1045, A572, 1070	450-700	170-450	0.312	.0020-.0040	No
						0.375	.0020-.0045	
						0.500	.0020-.0050	
						0.625	.0020-.0060	
	6 - 9	Low-alloy Steel	4140, 4340, P20, 8620, 300M	400-650	140-350	0.312	.0020-.0040	
						0.375	.0020-.0045	
						0.500	.0020-.0050	
						0.625	.0020-.0060	
	10 - 11	High-alloy Steel	H13, A2, D2, M2, T1	400-600	130-300	0.312	.0020-.0035	
						0.375	.0020-.0040	
						0.500	.0020-.0045	
						0.625	.0020-.0050	
M	12 - 14	Stainless Steel	410, 416, 440, 303, 304, 316, 15-5, 17-4	200-450	100-230	0.312	.0020-.0030	May be required at high speeds
0.375	.0025-.0035							
0.500	.0020-.0040							
0.625	.0020-.0045							
K	15 - 18	Iron	CLS. 20, 30, 45, 60-40-18, 100-70-03	500-800	265-550	0.312	.0020-.0050	No
						0.375	.0020-.0055	
						0.500	.0020-.0060	
						0.625	.0020-.0065	
S	31 - 37	High-Temp, Ti	Inconel, Hastelloy, 6Al-4V, 5Al-5Mo-5V-3Cr	65-250	65-165	0.312	.0010-.0020	Yes
						0.375	.0015-.0025	
						0.500	.0020-.0030	
						0.625	.0020-.0035	
H	38 - 39	Hardened Steel > 48	A2, O1, D2	150-300	65-165	0.312	.0010-.0020	Yes
						0.375	.0015-.0025	
						0.500	.0020-.0030	
						0.625	.0020-.0035	

Note: Feed and speed recommendations are starting operating parameters. They are only guidelines from which further optimization should take place. Operating parameters are influenced by many machining variables. These variables may cause for reductions in feeds and speed or dramatic increases. Additionally, DOC and WOC may need to be revised to optimize the tools performance.