



ISOPLUS™

MILLING PRODUCTS

Cutter Series (Style)

- DJ5T/DJ6T (90°)
- DQ5T/DQ6T (88°)
- DL5T/DL6T (85° screw-held)
- DK1G (85° wedge-held)
- DN5H/DN6H (45°)
- DL5H/DL6H (75°)
- 1DD1H/DD6H (Hi-Feed 12°)

Diameter Range

1.50" - 8.00"
40-315mm

Corners

.015" .031" .047" & .062" R
.031 x 45° Chamfer

Materials

Iron, CGI, Steel, Stainless Steel,
Hi-Temps, Titanium &
Aluminum



8-Index Mills That Tackle Difficult Applications

Features & Benefits:

- 3 popular Quad Insert sizes oriented at different angles for facing, shouldering and contouring
- Indexable designs with screw-held & wedge-held insert options
- Inserts equipped with pressed rake face geometry (positive geometry) on 2 sides; 8-Edge-Economy!
- Carbide and ceramic insert grade options
- Wiper insert options for improved surface finishes





ISOPPLUS™ 13 SERIES DJ5T/DJ6T

90° QUAD ROUGH & FINISH FACE MILL (13MM INSERT)

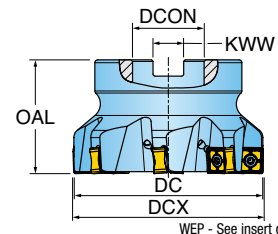
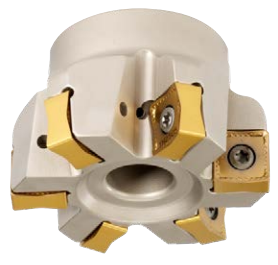
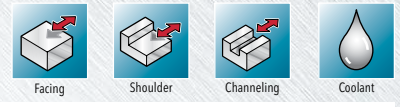

WEP - See insert drawing for wiper options.

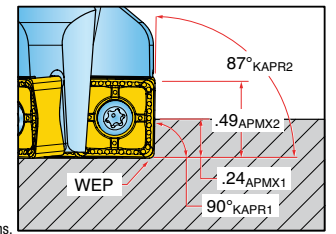

Part Number	DC Cutting Dia.	DCX Cutting Dia. Max.	OAL Overall Length	ZEFF Effective Teeth	DCON Bore Dia.	KWW Keyway	DBC Bolt Circle	CSP Coolant
DJ6T-20R01	2.000	2.025	1.570	5	0.750	0.312	NA	Yes
DJ6T-25R01	2.500	2.523	1.570	6	0.750	0.312	NA	Yes
DJ5T-30R01	3.000	3.021	1.750	8	1.000	0.375	NA	Yes
DJ6T-30R01	3.000	3.021	1.750	7	1.000	0.375	NA	Yes
DJ5T-40R01	4.000	4.020	2.375	10	1.500	0.625	NA	Yes
DJ6T-40R01	4.000	4.020	2.375	8	1.500	0.625	NA	Yes
DJ6T-50R01	5.000	5.018	2.375	10	1.500	0.625	NA	Yes
DJ5T-60R01	6.000	6.016	2.375	17	1.500	0.625	NA	No
DJ6T-60R01	6.000	6.016	2.375	12	1.500	0.625	NA	No
DJ5T-80R01	8.000	8.016	2.375	21	2.500	1.000	4.00	No
DJ6T-80R01	8.000	8.016	2.375	14	2.500	1.000	4.00	No

NOTE: Carbide insert screw torque is 35 in lbs. SiN insert screw torque is 30 in lbs.



ISOPPLUS™ 13 SERIES DQ5T/DQ6T - 88° FACE MILL (METRIC)

88° ROUGH & FINISH FACE MILL (13MM INSERT)

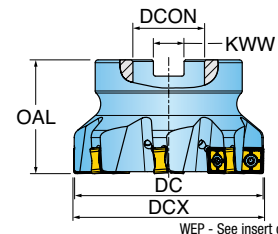

WEP - See insert drawing for wiper options.

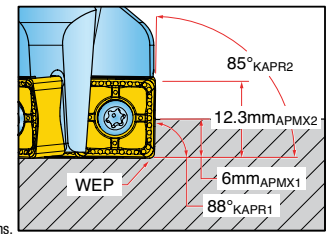

Part Number	DC Cutting Dia.	DCX Cutting Dia. Max.	OAL Overall Length	ZEFF Effective Teeth	DCON Bore Dia.	KWW Keyway	DBC Bolt Circle	CSP Coolant
DQ6T050R00	50.00 mm	51.20 mm	40.00 mm	5	22.00 mm	10.40 mm	NA	Yes
DQ6T063R00	63.00 mm	64.20 mm	40.00 mm	6	22.00 mm	10.40 mm	NA	Yes
DQ5T080R00	80.00 mm	81.20 mm	50.00 mm	9	27.00 mm	12.40 mm	NA	Yes
DQ6T080R00	80.00 mm	81.20 mm	50.00 mm	7	27.00 mm	12.40 mm	NA	Yes
DQ5T100R00	100.00 mm	101.20 mm	50.00 mm	11	32.00 mm	14.40 mm	NA	Yes
DQ6T100R00	100.00 mm	101.20 mm	50.00 mm	8	32.00 mm	14.40 mm	NA	Yes
DQ5T125R00	125.00 mm	126.20 mm	63.00 mm	14	40.00 mm	16.00 mm	NA	Yes
DQ6T125R00	125.00 mm	126.20 mm	63.00 mm	10	40.00 mm	16.00 mm	NA	Yes
DQ5T160R00	160.00 mm	161.10 mm	63.00 mm	18	40.00 mm	16.40 mm	NA	No
DQ6T160R00	160.00 mm	161.10 mm	63.00 mm	12	40.00 mm	16.40 mm	NA	No
DQ5T200R00	200.00 mm	201.10 mm	63.00 mm	22	60.00 mm	25.70 mm	101.6 mm	No
DQ6T200R00	200.00 mm	201.10 mm	63.00 mm	14	60.00 mm	25.70 mm	101.6 mm	No

NOTE: Carbide insert screw torque is 35 in lbs. SiN insert screw torque is 30 in lbs.



ISOPPLUS™ SERIES DJ5T/DJ6T & DQ5T/DQ6T INSERTS

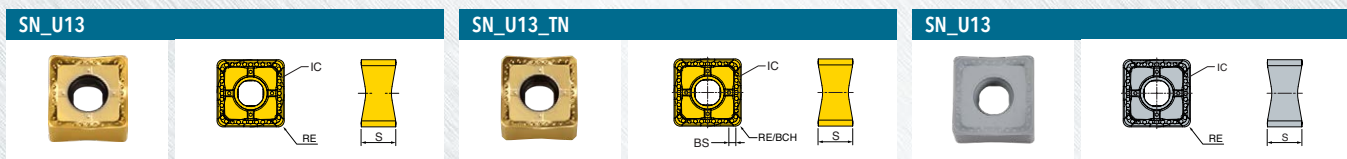

Part Number	Application	RE/BCH Corner Radius/ Chamfer	BS Wiper Length	IC Inscribed Circle Dia.	S Thickness (To Cutting Edge)	NOI Number of Indexes	IH Insert Hand	Grade									
									IN2505	IN2510	IN2530	IN2540	IN4015	IN4030	IN6515	IN71N	
SNGU130604N	Multi-Purpose	0.015 R	-	0.530	0.268	8	Neutral		•	•	•						•
SNMU130604N-M	Utility	0.015 R	-	0.530	0.272	8	Neutral			•							
SNGU130608N	Multi-Purpose	0.031 R	-	0.530	0.268	8	Neutral		•	•							•
SNGU130608TN	Multi-Purpose - Integrated Wiper	0.031 R	0.047	0.530	0.268	8	Neutral		•	•	•	•	•	•	•	•	•
SNGU1306ANTN	Multi-Purpose - Integrated Wiper	0.031 Chamfer	0.047	0.530	0.268	8	Neutral		•	•		•	•		•	•	
SNMU130608N-M	Utility	0.031 R	-	0.530	0.276	8	Neutral		•	•							
SNMU130608TN-M	Utility - Integrated Wiper	0.031 R	0.047	0.530	0.276	8	Neutral		•	•							•
SNMU1306ANTN-M	Utility - Integrated Wiper	0.031 Chamfer	0.047	0.530	0.272	8	Neutral										•
SNMU130608N-ML	Utility - Keen Edge	0.031 R	-	0.530	0.28	8	Neutral			•							
SNMU130608N	Utility - SiN for Iron	0.031 R	-	0.530	0.268	8	Neutral										•
SNGU130612N	Multi-Purpose	0.047 R	-	0.530	0.268	8	Neutral		•	•							
SNMU130612N-M	Utility	0.047 R	-	0.530	0.272	8	Neutral			•							
SNGU130616N	Multi-Purpose	0.062 R	-	0.530	0.268	8	Neutral		•		•	•	•		•	•	
SNGU130620TN	Multi-Purpose	0.079 R	-	0.530	0.268	8	Neutral		•	•							
SNMU130620N-M	Utility	0.079 R	-	0.530	0.268	8	Neutral		•	•							•



ISOPLUS™ 13 SERIES DL5T/DL6T

85° QUAD ROUGH FACE MILL (13MM INSERT)

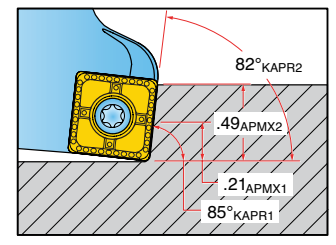
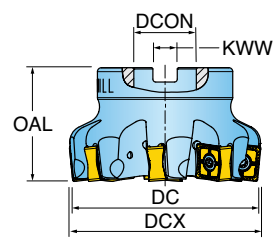
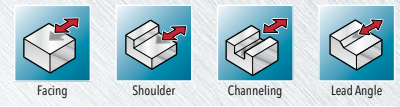

Part Number	DC Cutting Dia.	DCX Cutting Dia. Max.	OAL Overall Length	ZEFF Effective Teeth	DCON Bore Dia.	KWW Keyway
DL6T-20R01	2.000	2.11	1.570	5	0.750	0.312
DL6T-25R01	2.500	2.61	1.570	6	0.750	0.312
DL5T-30R01	3.000	3.11	1.750	8	1.000	0.375
DL5T-40R01	4.000	4.11	2.375	10	1.500	0.625
DL5T-50R01	5.000	5.11	2.375	13	1.500	0.625
DL5T-60R01	6.000	6.11	2.375	17	1.500	0.625

NOTE: Carbide insert screw torque is 35 in lbs. SiN insert screw torque is 30 in lbs.





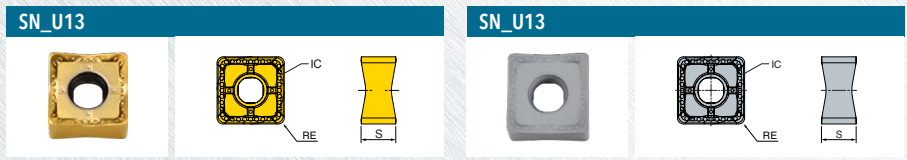





ISOPLUS™ SERIES DL5T/DL6T INSERTS



Part Number	Application	RE/BCH Corner Radius/ Chamfer	IC Inscribed Circle Dia.	S Thickness (To Cutting Edge)	NOI Number of Indexes	IH Insert Hand	Grade							
							IN2505	IN2510	IN2530	IN2540	IN4015	IN4030	IN6515	IN71N
SNGU130604N	Multi-Purpose	0.015 R	0.530	0.268	8	Neutral	•	•	•					•
SNMU130604N-M	Utility	0.015 R	0.530	0.272	8	Neutral		•						
SNGU130608N	Multi-Purpose	0.031 R	0.530	0.268	8	Neutral	•	•						•
SNMU130608N-M	Utility	0.031 R	0.530	0.276	8	Neutral	•	•						
SNMU130608N-ML	Utility - Keen Edge	0.031 R	0.530	0.28	8	Neutral			•					
SNMU130608N	Utility - SiN for Iron	0.031 R	0.530	0.268	8	Neutral								•
SNGU130612N	Multi-Purpose	0.047 R	0.530	0.268	8	Neutral	•	•						
SNMU130612N-M	Utility	0.047 R	0.530	0.272	8	Neutral			•					
SNGU130616N	Multi-Purpose	0.062 R	0.530	0.268	8	Neutral	•		•	•	•		•	•
SNGU130620TN	Multi-Purpose	0.079 R	0.530	0.268	8	Neutral	•	•						
SNMU130620N-M	Utility	0.079 R	0.530	0.268	8	Neutral	•	•						•



ISOPLUS™ SERIES DJ5T/DJ6T, DQ5T/DQ6T & DL5T/DL6T HARDWARE

Part Number	 Retention Bolt	 Insert Screw	 Driver Handle	 Driver Blade	 **OPTIONAL** Coolant Bolt	 **OPTIONAL** Torque Driver Handle	 **OPTIONAL** Preset Torque Bit for SiN	 **OPTIONAL** Preset Torque Bit for Carbide	 **OPTIONAL** Torque Driver Bit
DJ6T-20R01	SD-06-46	SM40-100-R0	DS-A00T	DS-T156B	SD-06-89	DS-A00-.25-T	DT-30-.25	DT-35-.25	DS-T15B1
DJ6T-25R01	SD-06-46	SM40-100-R0	DS-A00T	DS-T156B	SD-06-89	DS-A00-.25-T	DT-30-.25	DT-35-.25	DS-T15B1
DJ5T-30R01	SD-08-46	SM40-100-R0	DS-A00T	DS-T156B	SD-08-92	DS-A00-.25-T	DT-30-.25	DT-35-.25	DS-T15B1
DJ6T-30R01	SD-08-46	SM40-100-R0	DS-A00T	DS-T156B	SD-08-92	DS-A00-.25-T	DT-30-.25	DT-35-.25	DS-T15B1
DJ5T-40R01	SD-12-82	SM40-100-R0	DS-A00T	DS-T156B	SD-12-99	DS-A00-.25-T	DT-30-.25	DT-35-.25	DS-T15B1
DJ6T-40R01	SD-12-82	SM40-100-R0	DS-A00T	DS-T156B	SD-12-99	DS-A00-.25-T	DT-30-.25	DT-35-.25	DS-T15B1
DJ6T-50R01	SD-12-82	SM40-100-R0	DS-A00T	DS-T156B	SD-12-99	DS-A00-.25-T	DT-30-.25	DT-35-.25	DS-T15B1
DJ5T-60R01	-	SM40-100-R0	DS-A00T	DS-T156B	-	DS-A00-.25-T	DT-30-.25	DT-35-.25	DS-T15B1
DJ6T-60R01	-	SM40-100-R0	DS-A00T	DS-T156B	-	DS-A00-.25-T	DT-30-.25	DT-35-.25	DS-T15B1
DJ5T-80R01	-	SM40-100-R0	DS-A00T	DS-T156B	-	DS-A00-.25-T	DT-30-.25	DT-35-.25	DS-T15B1
DJ6T-80R01	-	SM40-100-R0	DS-A00T	DS-T156B	-	DS-A00-.25-T	DT-30-.25	DT-35-.25	DS-T15B1
DQ6T050R00	DIN912M12X30-12.9	SM40-100-R0	DS-A00T	DS-T156B	-	DS-A00-.25-T	DT-30-.25	DT-35-.25	DS-T15B1
DQ6T063R00	DIN912M12X30-12.9	SM40-100-R0	DS-A00T	DS-T156B	-	DS-A00-.25-T	DT-30-.25	DT-35-.25	DS-T15B1
DQ5T080R00	DIN912M12X35-12.9	SM40-100-R0	DS-A00T	DS-T156B	-	DS-A00-.25-T	DT-30-.25	DT-35-.25	DS-T15B1
DQ6T080R00	DIN912M12X35-12.9	SM40-100-R0	DS-A00T	DS-T156B	-	DS-A00-.25-T	DT-30-.25	DT-35-.25	DS-T15B1
DQ5T100R00	DIN912M16X30-12.9	SM40-100-R0	DS-A00T	DS-T156B	-	DS-A00-.25-T	DT-30-.25	DT-35-.25	DS-T15B1
DQ6T100R00	DIN912M16X30-12.9	SM40-100-R0	DS-A00T	DS-T156B	-	DS-A00-.25-T	DT-30-.25	DT-35-.25	DS-T15B1
DQ5T125R00	DIN 7984 M20X40-10.9	SM40-100-R0	DS-A00T	DS-T156B	-	DS-A00-.25-T	DT-30-.25	DT-35-.25	DS-T15B1
DQ6T125R00	DIN 7984 M20X40-10.9	SM40-100-R0	DS-A00T	DS-T156B	-	DS-A00-.25-T	DT-30-.25	DT-35-.25	DS-T15B1
DQ5T160R00	-	SM40-100-R0	DS-A00T	DS-T156B	-	DS-A00-.25-T	DT-30-.25	DT-35-.25	DS-T15B1
DQ6T160R00	-	SM40-100-R0	DS-A00T	DS-T156B	-	DS-A00-.25-T	DT-30-.25	DT-35-.25	DS-T15B1
DQ5T200R00	-	SM40-100-R0	DS-A00T	DS-T156B	-	DS-A00-.25-T	DT-30-.25	DT-35-.25	DS-T15B1
DQ6T200R00	-	SM40-100-R0	DS-A00T	DS-T156B	-	DS-A00-.25-T	DT-30-.25	DT-35-.25	DS-T15B1
DL6T-20R01	SD-06-46	SM40-100-R0	DS-A00T	DS-T156B	-	DS-A00-.25-T	DT-30-.25	DT-35-.25	DS-T15B1
DL6T-25R01	SD-06-46	SM40-100-R0	DS-A00T	DS-T156B	-	DS-A00-.25-T	DT-30-.25	DT-35-.25	DS-T15B1
DL5T-30R01	SD-08-46	SM40-100-R0	DS-A00T	DS-T156B	-	DS-A00-.25-T	DT-30-.25	DT-35-.25	DS-T15B1
DL5T-40R01	SD-12-82	SM40-100-R0	DS-A00T	DS-T156B	-	DS-A00-.25-T	DT-30-.25	DT-35-.25	DS-T15B1
DL5T-50R01	SD-12-82	SM40-100-R0	DS-A00T	DS-T156B	-	DS-A00-.25-T	DT-30-.25	DT-35-.25	DS-T15B1
DL5T-60R01	-	SM40-100-R0	DS-A00T	DS-T156B	-	DS-A00-.25-T	DT-30-.25	DT-35-.25	DS-T15B1



ISOPLUS™ 11 SERIES DK1G METRIC

85° ROUGH & FINISH FACE MILL (11MM INSERT)

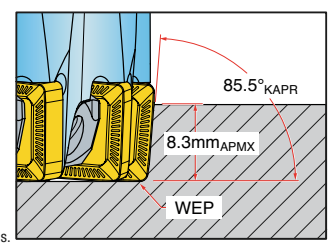
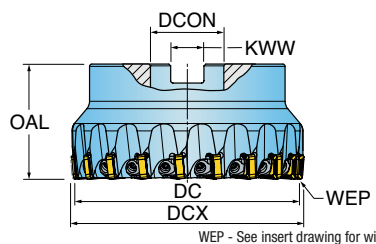

WEP - See insert drawing for wiper options.

Part Number	DC Cutting Dia.	DCX Cutting Dia. Max.	OAL Overall Length	ZEFF Effective Teeth	DCON Bore Dia.	KWW Keyway	DBC Bolt Circle	CSP Coolant
DK1G040R00	40.00 mm	41.4 mm	40.00 mm	6	16.00 mm	8.40 mm	NA	Yes
DK1G050R00	50.00 mm	51.4 mm	40.00 mm	8	22.00 mm	10.40 mm	NA	Yes
DK1G063R00	63.00 mm	64.4 mm	40.00 mm	11	22.00 mm	10.40 mm	NA	Yes
DK1G080R00	80.00 mm	81.4 mm	50.00 mm	15	27.00 mm	12.40 mm	NA	Yes
DK1G100R00	100.00 mm	101.4 mm	50.00 mm	19	32.00 mm	14.40 mm	NA	Yes



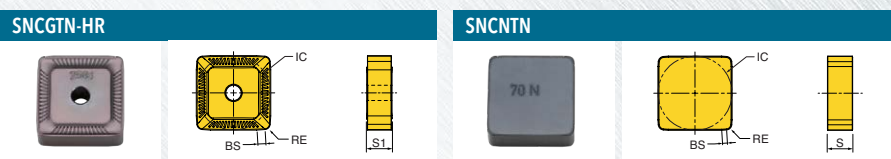





ISOPLUS™ SERIES DK1G INSERTS



Part Number	Application	RE Corner Radius	BS Wiper Length	IC Inscribed Circle Dia.	S Thickness (To Cutting Edge)	NOI Number of Indexes	IH Insert Hand	Grade	IN2504	IN4005	IN4030	IN70N
SNCG11T308TN-HR	Multi-Purpose	0.80 mm	1.20 mm	11 mm	3.60 mm	8	Neutral		•	•	•	
SNCN11T308TN	SiN for Iron	0.80 mm	0.70 mm	11 mm	3.60 mm	8	Neutral					•



ISOPPLUS™ SERIES DK1G HARDWARE

Part Number	 Differential Screw	 Wedge	 Coolant Wedge **OPTIONAL**	 Torx Driver	 Torque Driver Bit **OPTIONAL**	 Torque Driver Handle **OPTIONAL**	 Preset Torque Bit **OPTIONAL**	 Retention Bolt
DK1G040R00	SB040-03	2M0408R02	2M0408R01	DS-T09W	DS-T09B	DS-A00-.25-S	DT-18-.25	SB080-04
DK1G050R00	SB040-03	2M0408R02	2M0408R01	DS-T09W	DS-T09B	DS-A00-.25-S	DT-18-.25	ISO4762M10X25-12.9
DK1G063R00	SB040-03	2M0408R02	2M0408R01	DS-T09W	DS-T09B	DS-A00-.25-S	DT-18-.25	ISO4762M10X25-12.9
DK1G080R00	SB040-03	2M0408R02	2M0408R01	DS-T09W	DS-T09B	DS-A00-.25-S	DT-18-.25	ISO4762M12X35-12.9
DK1G100R00	SB040-03	2M0408R02	2M0408R01	DS-T09W	DS-T09B	DS-A00-.25-S	DT-18-.25	ISO4762M16X30-12.9



ISOPLUS™ 12 SERIES DN5H/DN6H

45° ROUGH & FINISH FACE MILL (12MM INSERT)

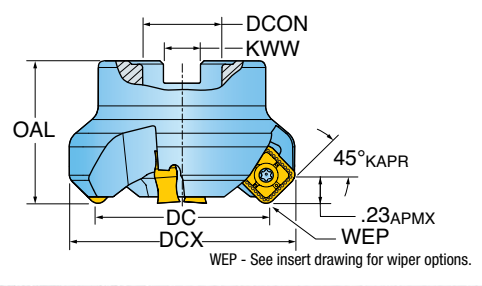
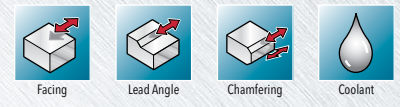

Part Number	DC Cutting Dia.	DCX Cutting Dia. Max.	OAL Overall Length	ZEFF Effective Teeth	DCON Bore Dia.	KWW Keyway	CSP Coolant
DN6H-20R01	2.000	2.57	1.750	4	.750	.312	Yes
DN5H-20R01	2.000	2.57	1.750	6	.750	.312	Yes
DN6H-25R01	2.500	3.07	1.750	6	1.000	.375	Yes
DN6H-30R01	3.000	3.57	1.750	7	1.000	.375	Yes
DN5H-30R01	3.000	3.57	1.750	10	1.000	.375	Yes
DN6H-40R01	4.000	4.57	2.375	8	1.500	.625	Yes
DN5H-40R01	4.000	4.57	2.375	12	1.500	.625	Yes
DN6H-50R01	5.000	5.57	2.375	9	1.500	.625	Yes
DN6H-60R01	6.000	6.57	2.000	12	1.500	.625	No
DN5H-60R01	6.000	6.57	2.000	20	1.500	.625	No

NOTE: Carbide insert screw torque is 35 in lbs. SiN insert screw torque is 30 in lbs.



ISOPPLUS™ 12 SERIES DN5H/DN6H METRIC

45° ROUGH & FINISH FACE MILL (12MM INSERT)

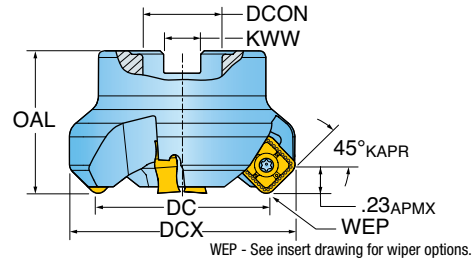
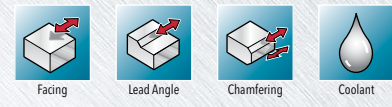

Part Number	DC Cutting Dia.	DCX Cutting Dia. Max.	OAL Overall Length	ZEFF Effective Teeth	DCON Bore Dia.	KWW Keyway	DBC Bolt Circle Dia.	CSP Coolant	HAND Hand
DN5H050R00	50.00 mm	64.5 mm	40.00 mm	6	22.00 mm	10.40 mm	-	Yes	Right
DN6H050R00	50.00 mm	64.5 mm	40.00 mm	4	22.00 mm	10.40 mm	-	Yes	Right
DN5H063R00	63.00 mm	77.5 mm	40.00 mm	8	22.00 mm	10.40 mm	-	Yes	Right
DN6H063R00	63.00 mm	77.5 mm	40.00 mm	6	22.00 mm	10.40 mm	-	Yes	Right
DN5H080R00	80.00 mm	94.5 mm	50.00 mm	10	27.00 mm	12.40 mm	-	Yes	Right
DN6H080R00	80.00 mm	94.5 mm	50.00 mm	7	27.00 mm	12.40 mm	-	Yes	Right
DN5H100R00	100.00 mm	114.5 mm	50.00 mm	12	32.00 mm	14.40 mm	-	Yes	Right
DN6H100R00	100.00 mm	114.5 mm	50.00 mm	8	32.00 mm	14.40 mm	-	Yes	Right
DN5H125R00	125.00 mm	139.5 mm	63.00 mm	16	40.00 mm	16.00 mm	-	Yes	Right
DN6H125R00	125.00 mm	139.5 mm	63.00 mm	10	40.00 mm	16.00 mm	-	Yes	Right
DN6H160R00	160.00 mm	174.5 mm	63.00 mm	12	40.00 mm	16.40 mm	66.7 mm	No	Right
DN5H200R00	200.00 mm	214.6 mm	63.00 mm	26	60.00 mm	25.70 mm	101.6 mm	No	Right
DN6H200R00	200.00 mm	214.6 mm	63.00 mm	18	60.00 mm	25.70 mm	101.6 mm	No	Right
DN6H250R00	250.00 mm	264.6 mm	63.00 mm	20	60.00 mm	25.70 mm	101.6 mm	No	NA

NOTE: Carbide insert screw torque is 35 in lbs. SiN insert screw torque is 30 in lbs.



ISOPLUS™ SERIES DN5H/DN6H INSERTS

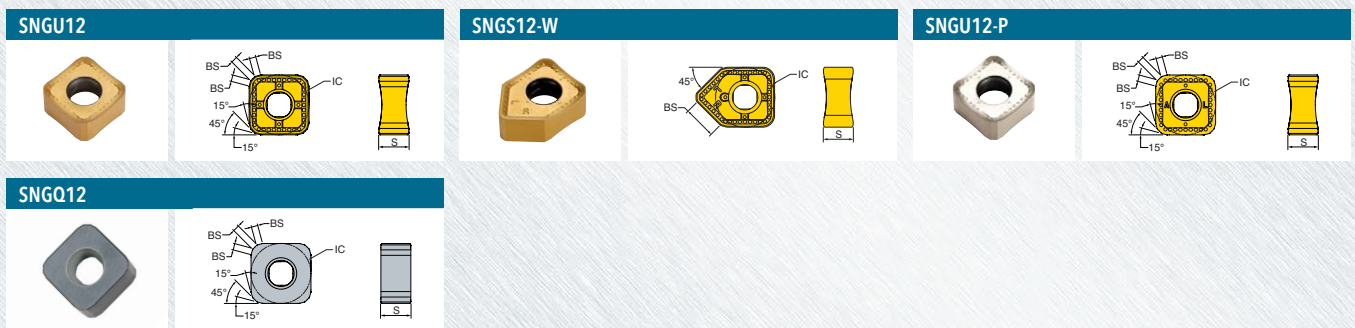









Part Number	Application	BCH Corner Chamfer	BS Wiper Length	IC Inscribed Circle Dia.	S Thickness (To Cutting Edge)	NOI Number of Indexes	IH Insert Hand	Grade	IN10K	IN2036	IN2505	IN2510	IN2530	IN2540	IN4015	IN4030	IN6515	IN7TN
SNGU1205ENN	Multi-Purpose	0.040	0.040	0.500	0.250	8	Neutral		•	•	•	•	•	•	•	•	•	
SNGS1205ANN-W	Wiper	0.040	0.275	0.500	0.250	2	Neutral				•	•						
SNGU1205EFN-P	Grd/Pol for Al	0.040	0.040	0.500	0.250	8	Neutral	•										
SNGQ1205ENN	SiN for Iron	0.040	0.040	0.500	0.251	8	Neutral											•

** Faceted corner simulates R.093.



ISOPLUS™ SERIES DN6H/DN5H HARDWARE

Part Number									
	Retention Bolt	**OPTIONAL** Coolant Bolt	Insert Screw	Driver Handle	Driver Blade	**OPTIONAL** Torque Driver Handle	**OPTIONAL** Preset Torque Bit for SIN	**OPTIONAL** Preset Torque Bit for Carbide	**OPTIONAL** Torque Driver Bit
DN6H-20R01	SD-06-46	SD-06-89	SM40-100-R0	DS-A00T	DS-T156B	DS-A00-.25-T	DT-30-.25	DT-35-.25	DS-T15B1
DN5H-20R01	SD-06-46	SD-06-89	SM40-100-R0	DS-A00T	DS-T156B	DS-A00-.25-T	DT-30-.25	DT-35-.25	DS-T15B1
DN6H-25R01	SD-08-46	SD-08-92	SM40-100-R0	DS-A00T	DS-T156B	DS-A00-.25-T	DT-30-.25	DT-35-.25	DS-T15B1
DN6H-30R01	SD-08-46	SD-08-92	SM40-100-R0	DS-A00T	DS-T156B	DS-A00-.25-T	DT-30-.25	DT-35-.25	DS-T15B1
DN5H-30R01	SD-08-46	SD-08-92	SM40-100-R0	DS-A00T	DS-T156B	DS-A00-.25-T	DT-30-.25	DT-35-.25	DS-T15B1
DN6H-40R01	SD-12-82	SD-12-99	SM40-100-R0	DS-A00T	DS-T156B	DS-A00-.25-T	DT-30-.25	DT-35-.25	DS-T15B1
DN5H-40R01	SD-12-82	SD-12-99	SM40-100-R0	DS-A00T	DS-T156B	DS-A00-.25-T	DT-30-.25	DT-35-.25	DS-T15B1
DN6H-50R01	SD-12-82	SD-12-99	SM40-100-R0	DS-A00T	DS-T156B	DS-A00-.25-T	DT-30-.25	DT-35-.25	DS-T15B1
DN6H-60R01	-	-	SM40-100-R0	DS-A00T	DS-T156B	DS-A00-.25-T	DT-30-.25	DT-35-.25	DS-T15B1
DN5H-60R01	-	-	SM40-100-R0	DS-A00T	DS-T156B	DS-A00-.25-T	DT-30-.25	DT-35-.25	DS-T15B1
DN5H050R00	DIN 7984 M10X25-10.9	-	SM40-100-R0	DS-A00T	DS-T156B	DS-A00-.25-T	DT-30-.25	DT-35-.25	DS-T15B1
DN6H050R00	DIN 7984 M10X25-10.9	-	SM40-100-R0	DS-A00T	DS-T156B	DS-A00-.25-T	DT-30-.25	DT-35-.25	DS-T15B1
DN5H063R00	DIN 7984 M10X25-10.9	-	SM40-100-R0	DS-A00T	DS-T156B	DS-A00-.25-T	DT-30-.25	DT-35-.25	DS-T15B1
DN6H063R00	DIN 7984 M10X25-10.9	-	SM40-100-R0	DS-A00T	DS-T156B	DS-A00-.25-T	DT-30-.25	DT-35-.25	DS-T15B1
DN5H080R00	DIN 7984 M12X30-10.9	-	SM40-100-R0	DS-A00T	DS-T156B	DS-A00-.25-T	DT-30-.25	DT-35-.25	DS-T15B1
DN6H080R00	DIN 7984 M12X30-10.9	-	SM40-100-R0	DS-A00T	DS-T156B	DS-A00-.25-T	DT-30-.25	DT-35-.25	DS-T15B1
DN5H100R00	DIN 7984 M16X35-10.9	-	SM40-100-R0	DS-A00T	DS-T156B	DS-A00-.25-T	DT-30-.25	DT-35-.25	DS-T15B1
DN6H100R00	DIN 7984 M16X35-10.9	-	SM40-100-R0	DS-A00T	DS-T156B	DS-A00-.25-T	DT-30-.25	DT-35-.25	DS-T15B1
DN5H125R00	DIN 7984 M20X40-10.9	-	SM40-100-R0	DS-A00T	DS-T156B	DS-A00-.25-T	DT-30-.25	DT-35-.25	DS-T15B1
DN6H125R00	DIN 7984 M20X40-10.9	-	SM40-100-R0	DS-A00T	DS-T156B	DS-A00-.25-T	DT-30-.25	DT-35-.25	DS-T15B1
DN6H160R00	-	-	SM40-100-R0	DS-A00T	DS-T156B	DS-A00-.25-T	DT-30-.25	DT-35-.25	DS-T15B1
DN5H200R00	-	-	SM40-100-R0	DS-A00T	DS-T156B	DS-A00-.25-T	DT-30-.25	DT-35-.25	DS-T15B1
DN6H200R00	-	-	SM40-100-R0	DS-A00T	DS-T156B	DS-A00-.25-T	DT-30-.25	DT-35-.25	DS-T15B1
DN6H250R00	-	-	SM40-100-R0	DS-A00T	DS-T156B	DS-A00-.25-T	DT-30-.25	DT-35-.25	DS-T15B1

ISOPLUS™ 12 SERIES DL5H/DL6H

75° ROUGH & FINISH FACE MILL (12MM INSERT)

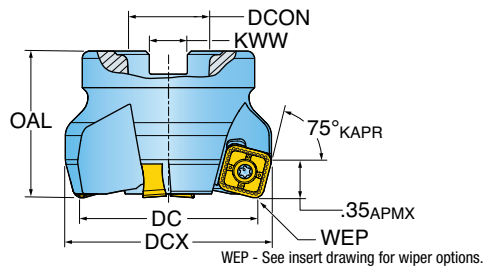
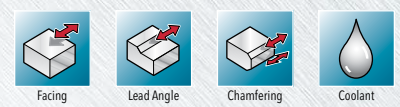

Part Number	DC Cutting Dia.	DCX Cutting Dia. Max.	OAL Overall Length	ZEFF Effective Teeth	DCON Bore Dia.	KWW Keyway	CSP Coolant
DL5H-20R01	2.000	2.300	1.750	6	0.750	0.312	Yes
DL6H-20R01	2.000	2.300	1.750	4	0.750	0.312	Yes
DL6H-25R01	2.500	2.800	1.750	6	1.000	0.375	Yes
DL6H-30R01	3.000	3.300	1.750	7	1.000	0.375	No
DL6H-40R01	4.000	4.300	2.000	8	1.500	0.625	No
DL6H-60R01	6.000	6.300	2.000	12	1.500	0.625	No

NOTE: Carbide insert screw torque is 35 in lbs. SiN insert screw torque is 30 in lbs.

ISOPLUS™ 12 SERIES 1DD1H

HI-FEED END MILL (12MM INSERT)

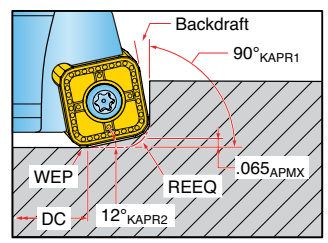
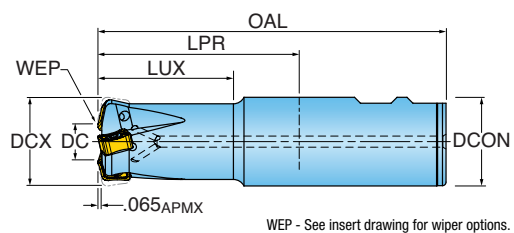

Part Number	DCX Cutting Dia. Max	DC Cutting Diameter	LUX Usable Length Max.	LPR Protruding Length	OAL Overall Length	ZEFF Effective Teeth	REEQ Program Radius Equivalent	DCON Shank Diameter	CSP Coolant
1DD1H-1502586R01	1.500	0.773	2.50	3.75	6.00	3	0.155	1.500	Yes

NOTE: Carbide insert screw torque is 35 in lbs. SiN insert screw torque is 30 in lbs. * Program as square bottom endmill with noted corner radius (REEQ).

ISOPLUS™ 12 SERIES 1DD1H

HI-FEED MODULAR END MILL (12MM INSERT)

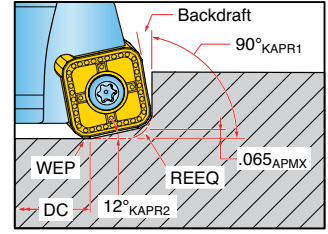
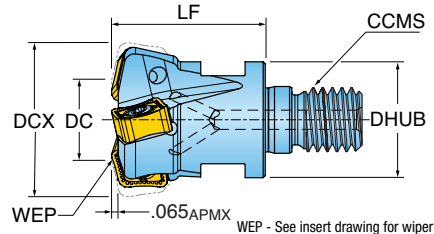

Part Number	DCX Cutting Dia. Max	DC Cutting Diameter	LF Functional Length	ZEFF Effective Teeth	REEQ Program Radius Equivalent	DHUB Hub Diameter	CCMS Connection Code	CSP Coolant
1DD1H-15015X8R01	1.500	0.773	2.45	3	0.155	1.13	TopOn M16	Yes

* Program as square bottom endmill with noted corner radius (REEQ).
NOTE: Carbide insert screw torque is 35 in lbs. SiN insert screw torque is 30 in lbs.

ISOPLUS™ 12 SERIES DD6H

HI-FEED FACE MILL (12MM INSERT)

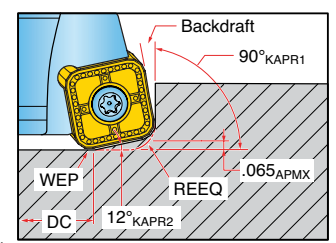
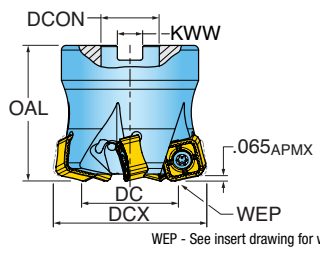

Part Number	DCX Cutting Dia. Max	DC Cutting Diameter	OAL Overall Length	ZEFF Effective Teeth	REEQ Program Radius Equivalent	DCON Bore Diameter	KWW Keyway	CSP Coolant
DD6H-20R01	2.000	1.252	1.65	5	0.155	0.750	0.31	Yes
DD6H-25R01	2.500	1.749	1.65	6	0.155	0.750	0.31	Yes
DD6H-30R01	3.000	2.252	1.75	7	0.155	1.000	0.38	Yes
DD6H-40R01	4.000	3.252	2.38	9	0.155	1.500	0.63	Yes
DD6H-50R01	5.000	4.254	2.38	11	0.155	1.500	0.63	Yes
DD6H-60R01	6.000	5.253	2.38	13	0.155	1.500	0.63	No

* Program as square bottom endmill with noted corner radius (REEQ).
NOTE: Carbide insert screw torque is 35 in lbs. SiN insert screw torque is 30 in lbs.



ISOPLUS™ SERIES DL5H/DL6H, 1DD1H, DD6H INSERTS

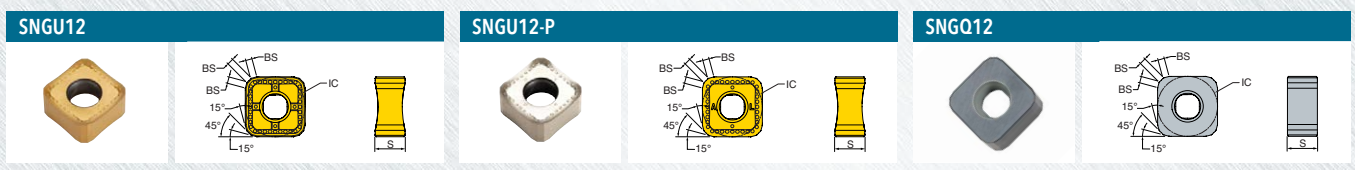

Part Number	Application	BCH/BS Corner Chamfer/ Wiper Length	IC Inscribed Circle Dia.	S Thickness (To Cutting Edge)	NOI Number of Indexes	IH Insert Hand	Grade	IN10K	IN2036	IN2505	IN2510	IN2530	IN2540	IN4015	IN4030	IN6515	IN71N
SNGU1205ENN	Multi-Purpose	0.040	0.500	0.250	8	Neutral		•	•	•	•	•	•	•	•	•	
SNGU1205EFN-P	Grd/Pol for Al	0.040	0.500	0.250	8	Neutral	•										
SNGQ1205ENN	SiN for Iron	0.040	0.500	0.251	8	Neutral											•

** Faceted corner simulates R.093.

ISOPLUS™ SERIES DL5H/DL6H, 1DD1H, DD6H HARDWARE

Part Number										
	Retention Bolt	**OPTIONAL** Coolant Bolt	Insert Screw	Driver Handle	Driver Blade	**OPTIONAL** Torque Driver Handle	**OPTIONAL** Preset Torque Bit for SiN	**OPTIONAL** Preset Torque Bit for Carbide	**OPTIONAL** Torque Driver Bit	**OPTIONAL** Wrench
DL5H-20R01	SD-06-46	SD-06-89	SM40-100-R0	DS-A00T	DS-T156B	DS-A00-.25-T	DT-30-.25	DT-35-.25	DS-T15B1	-
DL6H-20R01	SD-06-46	SD-06-89	SM40-100-R0	DS-A00T	DS-T156B	DS-A00-.25-T	DT-30-.25	DT-35-.25	DS-T15B1	-
DL6H-25R01	SD-08-46	SD-08-92	SM40-100-R0	DS-A00T	DS-T156B	DS-A00-.25-T	DT-30-.25	DT-35-.25	DS-T15B1	-
DL6H-30R01	-	-	SM40-100-R0	DS-A00T	DS-T156B	DS-A00-.25-T	DT-30-.25	DT-35-.25	DS-T15B1	-
DL6H-40R01	-	-	SM40-100-R0	DS-A00T	DS-T156B	DS-A00-.25-T	DT-30-.25	DT-35-.25	DS-T15B1	-
DL6H-60R01	-	-	SM40-100-R0	DS-A00T	DS-T156B	DS-A00-.25-T	DT-30-.25	DT-35-.25	DS-T15B1	-
1DD1H-1502586R01	-	-	SM40-100-R0	DS-A00T	DS-T156B	DS-A00-.25-T	DT-30-.25	DT-35-.25	DS-T15B1	-
1DD1H-15015X8R01	-	-	SM40-100-R0	DS-A00T	DS-T156B	DS-A00-.25-T	DT-30-.25	DT-35-.25	DS-T15B1	622MM
DD6H-20R01	SD-06-47	SD-06-A6	SM40-100-R0	DS-A00T	DS-T156B	DS-A00-.25-T	DT-30-.25	DT-35-.25	DS-T15B1	-
DD6H-25R01	SD-06-47	SD-06-A6	SM40-100-R0	DS-A00T	DS-T156B	DS-A00-.25-T	DT-30-.25	DT-35-.25	DS-T15B1	-
DD6H-30R01	SD-08-46	SD-08-92	SM40-100-R0	DS-A00T	DS-T156B	DS-A00-.25-T	DT-30-.25	DT-35-.25	DS-T15B1	-
DD6H-40R01	SD-12-82	SD-12-99	SM40-100-R0	DS-A00T	DS-T156B	DS-A00-.25-T	DT-30-.25	DT-35-.25	DS-T15B1	-
DD6H-50R01	SD-12-82	SD-12-99	SM40-100-R0	DS-A00T	DS-T156B	DS-A00-.25-T	DT-30-.25	DT-35-.25	DS-T15B1	-
DD6H-60R01	-	-	SM40-100-R0	DS-A00T	DS-T156B	DS-A00-.25-T	DT-30-.25	DT-35-.25	DS-T15B1	-

ISOPLUS™ DJ_T / DL_T OPERATING GUIDELINES

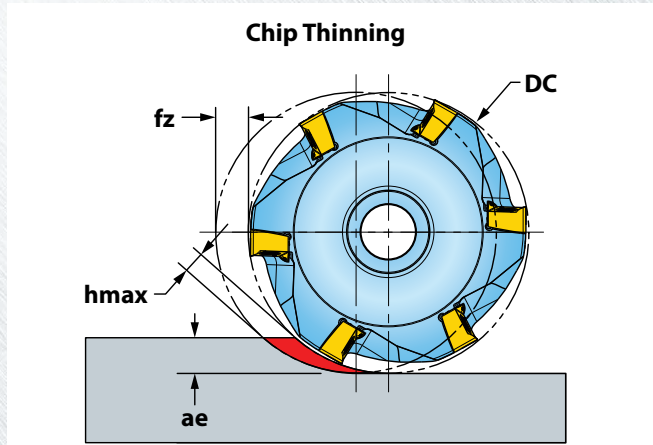

* Chip Thinning Calculator is recommended to ensure hmax falls within fz range.

ISO	Materials			Vc Cutting Speed SFM	fz* Feed/Tooth (inch)	Harder <-----> Tougher						Coolant
	Mat'l Group #VDI 3323	Type	Examples			Ceramic		Carbide				
						IN71N	IN2540	IN2510	IN4015 IN6515	IN2505	IN2530 IN4030	
P	1 - 5	Non-alloy Steel	1018, A36, 1045, A572, 1070	400-1000	.003-.015							No
	6 - 9	Low-alloy Steel	4140, 4340, P20, 8620, 300M	350-700		3			2	1		
	10 - 11	High-alloy Steel	H13, A2, D2, M2, T1	300-600								
M	12 - 13	Stainless Steel (Ferritic & Martensitic)	410, 416, 440	400-700	.003-.008		3			2	1	May not be required at high speeds
	14	Stainless Steel (Austenitic)	303, 304, 316, 15-5, 17-4	300-600								
K	15 - 16	Gray Cast Iron	CLS. 20, 30, 45	500-1000	.003-.010			1	2	3	4	No
				1800-3000	.003-.008	1						
	17 - 20	Nodular Cast Iron	60-40-18, 100-70-03	400-800	.003-.009			2	1	3	4	No
				1500-2500	.003-.007	1						
S	31 - 35	High-Temp Alloys	Inconel, Hastelloy, Nimonic, Monel	75-120	.003-.006					2	1	Yes
	36 - 37	Titanium Alloys	6Al-4V, 5Al-5Mo-5V-3Cr	100-150	.004-.007					1	2	

Note: Feed and speed recommendations are starting operating parameters. They are only guidelines from which further optimization should take place. Operating parameters are influenced by many machining variables. These variables may cause for reductions in feeds and speed or dramatic increases. Additionally, DOC and WOC may need to be revised to optimize the tools performance.

ISOPPLUS™ DK1G OPERATING GUIDELINES

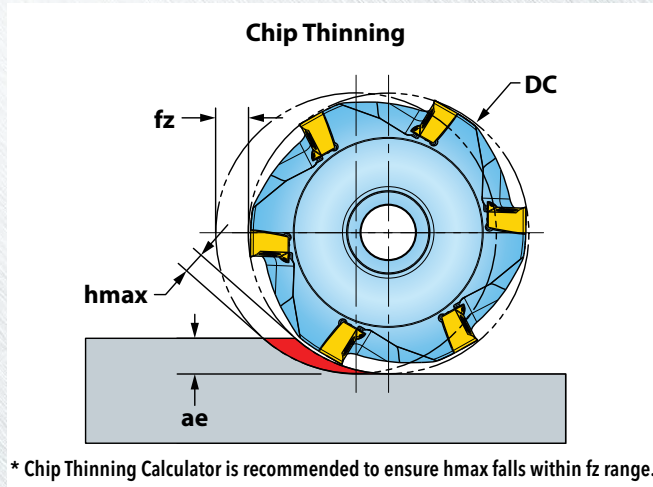

* Chip Thinning Calculator is recommended to ensure h_{max} falls within f_z range.

ISO	Materials			Vc Cutting Speed SFM	fz* Feed/Tooth (inch)	Harder <-----> Tougher				Coolant
	Mat'l Group #VDI 3323	Type	Examples			Ceramic		Carbide		
						IN70N	IN2504	IN4005	IN4030	
P	1 - 5	Non-alloy Steel	1018, A36, 1045, A572, 1070	400-1000	.003-.013					No
	6 - 9	Low-alloy Steel	4140, 4340, P20, 8620, 300M	350-700				2	2	
	10 - 11	High-alloy Steel	H13, A2, D2, M2, T1	300-600						
K	15 - 16	Gray Cast Iron	CLS. 20, 30, 45	500-1000	.003-.013		1	2	3	No
				1800-3000		1				
	17 - 20	Nodular Cast Iron	60-40-18, 100-70-03	400-800	.003-.012		1	2	3	No
				1500-2500		1				
		CGI	CGI	300-500	.003-.005		1			
H	38 thru 39	Hardened Steel >48	A2, O1, D2	150-300	.003-.007		1	2		No

Note: Feed and speed recommendations are starting operating parameters. They are only guidelines from which further optimization should take place. Operating parameters are influenced by many machining variables. These variables may cause for reductions in feeds and speed or dramatic increases. Additionally, DOC and WOC may need to be revised to optimize the tools performance.

ISOPLUS™ DN_H / DL_H OPERATING GUIDELINES

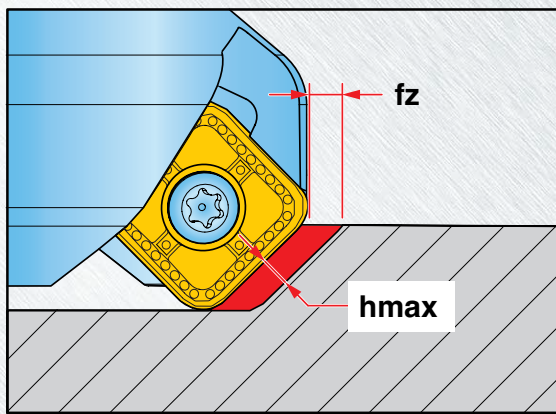

* Chip Thinning Calculator is recommended to ensure hmax falls within fz range.

ISO	Materials			Vc Cutting Speed SFM	fz* Feed/Tooth (inch)	Harder <-----> Tougher								Coolant	
	Mat'l Group #VDI 3323	Type	Examples			Ceramic		Carbide							
						IN71N	IN2540	IN10K	IN2510	IN4015 IN6515	IN2505	IN2530 IN4030	IN2036		
P	1 - 5	Non-alloy Steel	1018, A36, 1045, A572, 1070	400-1000	.004-.015										No
	6 - 9	Low-alloy Steel	4140, 4340, P20, 8620, 300M	350-700		3					2	1			
	10 - 11	High-alloy Steel	H13, A2, D2, M2, T1	300-600											
M	12 - 13	Stainless Steel (Fer- ritic & Martensitic)	410, 416, 440	400-700	.004-.010	4					3	2	1	May not be required at high speeds	
	14			Stainless Steel (Austenitic)			303, 304, 316, 15-5, 17-4	300-600							
K	15 - 16	Gray Cast Iron	CLS. 20, 30, 45	500-1000	.004-.015				1	2	3	4	No		
				1800-3000	.004-.008	1									
	17 - 20	Nodular Cast Iron	60-40-18, 100-70-03	400-800	.004-.012				2	1	3	4	No		
				1500-2500	.004-.007	1									
N	21 - 30	Aluminum	7075, 6061	1000-3000	.004-.015			1	2				Yes		
S	31 - 35	High-Temp Alloys	Inconel, Hastelloy, Nimonic, Monel	75-120	.004-.006						3	2	1	Yes	
	36 - 37	Titanium Alloys	6Al-4V, 5Al-5Mo-5V-3Cr	100-150	.004-.008						2	3	1		

Note: Feed and speed recommendations are starting operating parameters. They are only guidelines from which further optimization should take place. Operating parameters are influenced by many machining variables. These variables may cause for reductions in feeds and speed or dramatic increases. Additionally, DOC and WOC may need to be revised to optimize the tools performance.



ISOPLUS™ 1DD1H & DD6H OPERATING GUIDELINES

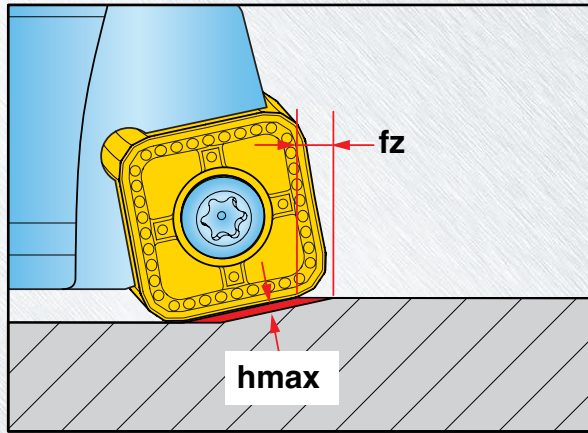

* Chip Thinning Calculator is recommended to ensure hmax falls within fz range.

ISO	Materials			Vc Cutting Speed SFM	fz* Feed/Tooth (inch)	ap Rec. Axial Depth of Cut (inch)	Harder <-----> Tougher								Coolant	
	Mat'l Group #VDI 3323	Type	Examples				Ceramic		Carbide							
							IN71N	IN2540	IN10K	IN2510	IN4015	IN6515	IN2505	IN2530		IN4030
P	1 - 5	Non-alloy Steel	1018, A36, 1045, A572, 1070	400-1000	.014-.060	.008-.065										No
	6 - 9	Low-alloy Steel	4140, 4340, P20, 8620, 300M	350-700			3				2	1				
	10 - 11	High-alloy Steel	H13, A2, D2, M2, T1	300-600												
M	12 - 13	Stainless Steel (Ferritic & Martensitic)	410, 416, 440	400-700	.014-.050	.008-.065									May not be required at high speeds	
	14	Stainless Steel (Austenitic)	303, 304, 316, 15-5, 17-4	300-600			4				3	2	1			
K	15 - 16	Gray Cast Iron	CLS. 20, 30, 45	500-1000	.014-.060	.008-.065			1	2	3	4		No		
				1800-3000	.004-.035	.008-.065	1									
	17 - 20	Nodular Cast Iron	60-40-18, 100-70-03	400-800	.014-.055	.008-.065				2	1	3	4	No		
				1500-2500	.014-.030	.008-.065	1									
N	21 - 30	Aluminum	7075, 6061	1000-3000	.014-.060	.008-.065			1	2				Yes		
S	31 - 35	High-Temp Alloys	Inconel, Hastelloy, Nimonic, Monel	75-120	.014-.040	.008-.065						3	2	1	Yes	
	36 - 37	Titanium Alloys	6Al-4V, 5Al-5Mo-5V-3Cr	100-150	.014-.040	.008-.065						2	3	1		

Note: Feed and speed recommendations are starting operating parameters. They are only guidelines from which further optimization should take place. Operating parameters are influenced by many machining variables. These variables may cause for reductions in feeds and speed or dramatic increases. Additionally, DOC and WOC may need to be revised to optimize the tools performance.

ISOPLUS™ SERIES 1DD1H/DD6H RAMPING DATA

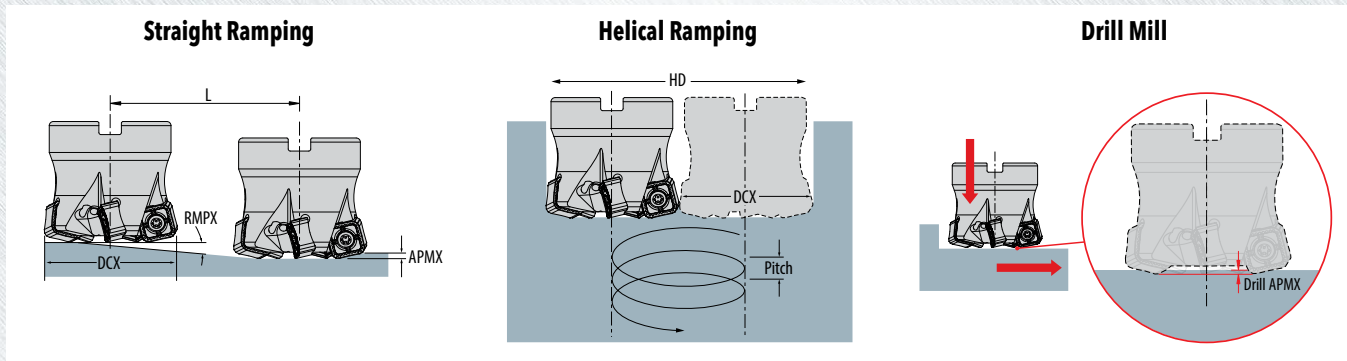

DC Cutter Diameter	Straight Ramp			Helical Ramp			Drill Mill
	RMPX Ramp Angle Max.	APMX Depth of Cut Max.	L Ramp Length Min.	HD Hole Dia. Min.	HD Hole Dia. Max.	Pitch Max.	Drill APMX Depth of Cut Max.
1.500	-	-	-	-	-	-	-
2.000	1.14	0.065	3.2	3.10	4.00	0.024	0.024
2.500	0.86	0.065	4.3	4.10	5.00	0.024	0.024
3.000	0.66	0.065	5.6	5.10	6.00	0.024	0.024
4.000	0.45	0.065	8.2	7.10	8.00	0.024	0.024
5.000	0.34	0.065	10.9	9.10	10.00	0.024	0.024
6.000	0.27	0.065	13.7	11.10	12.00	0.024	0.024



ISOPPLUS™ TECHNICAL INFORMATION

SNGS12-W Wiper Position

