

MILLING - INDEXABLE

Cutter Series (Depth of Cut)

1ZG3D (.039") **NEW**
1ZG3F, TG1Q, TG2Q (.060")
DG1H, DG2H (.098")

Insert Series

LNXF06 (6 mm) **NEW**
LNXF09 (9 mm)
TNXN12 (12 mm)

Insert Grades

IN76N - SiAlON

Diameter Range

0.625"-3.000"

Materials

High-Temp Alloys

Applications

Aerospace
Power Generation
Defense

CERASPEED™

NEW

6 mm



9 mm



12 mm

NEW Smaller Size Ceramic Hi-Feed Insert for Exceptional Productivity

- » Double-sided inserts with 4 cutting edges.
- » Dimpled inserts and top clamp holder design provide multidirectional clamping force.
- » Smaller insert provides higher cutter densities.
- » SiAlON grade IN76N allows cutting speeds up to 36 times greater than solid carbide.



SPEEDUP
HIGH SPEED & FEED
EXPANSION

See it in
action! »



WINSPEED
ADVANCED MACHINING

ingersoll-imc.com



Ingersoll's CERASFEED indexable ceramic hi-feed milling line for difficult-to-cut HRSA materials now includes a new 6 mm IC insert!

The new LNXF06, 6 mm IC size, will complement the existing 9 mm and 12 mm IC size offering. A greater application range is now possible!

The addition of the new smaller 6 mm IC insert allows for smaller tool diameters, .625 through 1.250 inch. This new and smaller insert series also makes it possible for higher cutter body insert densities. This new LNXF06 insert along with its supportive cutter series 1ZG3D also offers three different cutter series options. New cutter body offerings include end mill, Top-On and Chip Surfer options.

The CERASFEED hi-feed milling family of products will ignite your milling process, reduce cycle times, and increase through-put! These unique ceramic indexable high-feed milling options will allow for newfound productivity in the aerospace, power generation and defense industries!

FEATURES & BENEFITS:

- Cutter body options include Face Mill, End Mill, Top-On and Chip Surfer
- Cutter diameter range, .625" up to 3.000"
- Higher insert densities for super productivity!
- New SiAlON grade IN76N for demanding milling processes!
- SFM up to 36 times greater than solid carbide (60-90 SFM Carbide versus 3300 SFM Ceramic)!
- Depth of cut (DOC) capability from 1 mm (.039) to 2.5 mm (.098)
- Unique and optimally designed high-feed insert geometries, double-sided
- Inserts offer 4 or 6 cutting edges for cost-effective machining and economy!

LNXF 06 / 09 FEATURES

- Double-sided four corner dimple type insert

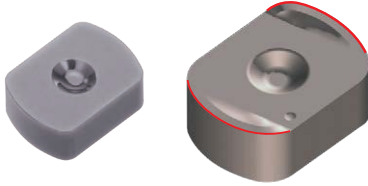

- Unique insert for high feed applications
- Large corner radius for increased tool life
- Rigid design with stable machining



- Positive rake angle and good chip evacuation
- Strong clamping by dimple type insert and clamp

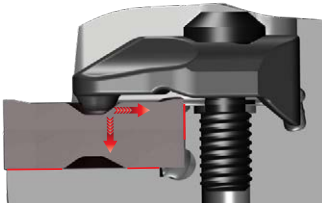

TNXN 12 FEATURES

- Strong double-sided six corner insert

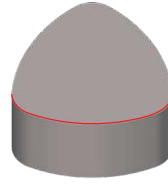

- Large corner radius for high feed machining-increased tool life
- Three-sided contact for stable clamping



- Digital air cooling through the wedge clamp

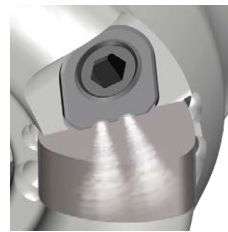

New IN76N grade brings increased performance when milling high temperature, high nickel-based alloys such as Inconel, Nimonic and Waspaloy. IN76N provides excellent toughness and its anti-chipping capabilities make it a good choice for interrupted and continuous cutting. New grade, IN76N offer the following benefits:

- Ideal for high temperature alloy machining and tougher when compared to the whisker ceramic grade
- Offering extreme toughness enabling higher feeds and heavier depths of cut
- Ideal for roughing milling applications
- Excellent in providing thermal shock resistance and thermal conductivity



Applied Parts



6 mm • Series 1ZG3D **NEW**

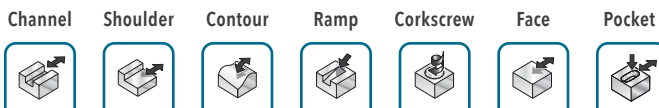

HI-FEED, INDEXABLE CERAMIC END MILL - CYLINDRICAL (6 MM INSERT)

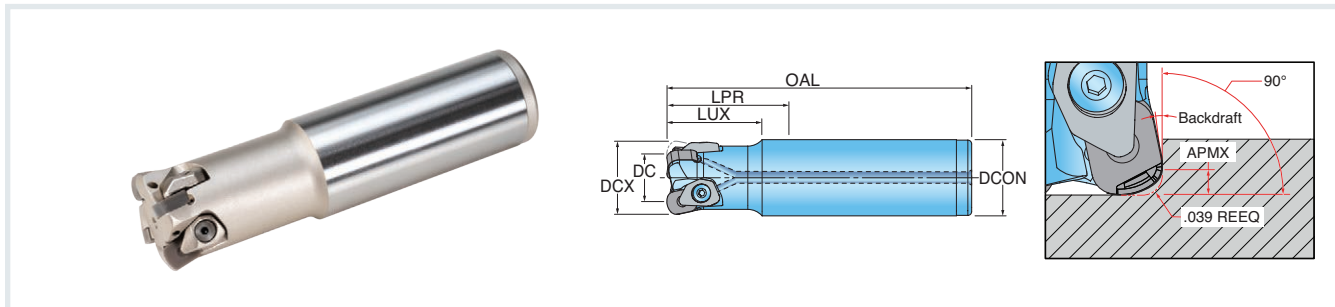

Part Number	DCX Cutting Dia Max.	DC Cutting Dia.	APMX Depth of Cut Max.	OAL Overall Length	ZEFF Eff. Teeth	DCON Shank Dia.	LUX Usable Length Max.	LPR Protruding Length	CSP Coolant (air only)	RMPX Ramp Angle Max.
INCH										
1ZG3D-06010R7R01	0.625	0.333	0.039	3.250	2	0.625	1.000	1.34	No	0.5°
1ZG3D-07010S7R01	0.750	0.455	0.039	3.250	3	0.750	1.000	1.22	Yes	0.5°
1ZG3D-10016S1R01	1.000	0.700	0.039	4.000	4	1.000	1.600	1.79	Yes	0.4°
1ZG3D-12016S9R01	1.250	0.948	0.039	4.750	5	1.250	1.600	2.47	Yes	0.3°



6 mm • Series 1ZG3D **NEW**

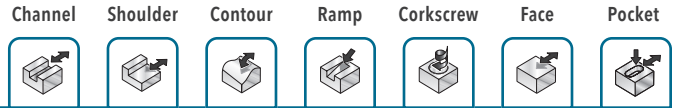

HI-FEED, INDEXABLE CERAMIC MODULAR END MILL - TOPON (6 MM INSERT)

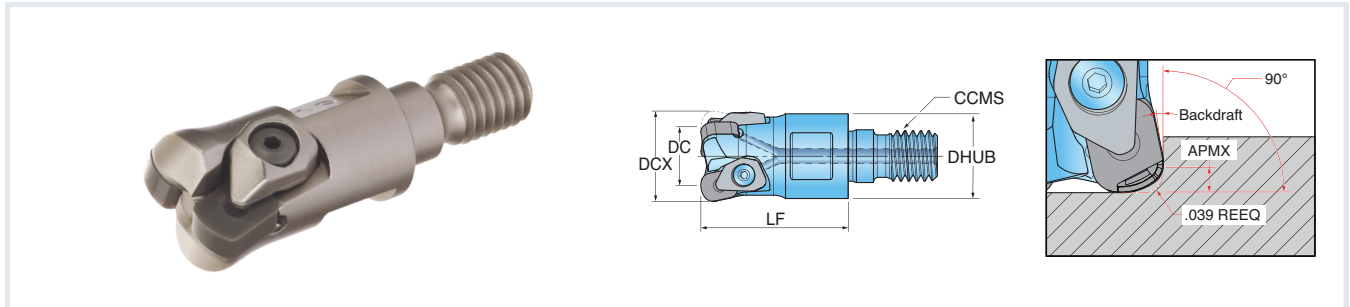

Part Number	DCX Cutting Dia Max.	DC Cutting Dia.	APMX Depth of Cut Max.	LF Functional Length	ZEFF Eff. Teeth	DHUB Hub Dia.	CCMS Connection Code Machine Side	RMPX Ramp Angle Max.	CSP Coolant (air only)
INCH									
1ZG3D-06010X5R01	0.625	0.333	0.039	0.980	2	0.51	TopOn M08	0.5°	No
1ZG3D-07012X6R01	0.750	0.455	0.039	1.180	3	0.71	TopOn M10	0.5°	Yes
1ZG3D-10014X7R01	1.000	0.700	0.039	1.370	4	0.82	TopOn M12	0.4°	Yes
1ZG3D-12016X8R01	1.250	0.984	0.039	1.570	5	1.14	TopOn M16	0.3°	Yes

6 mm • Series 1ZG3D **NEW**

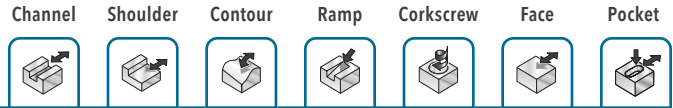

HI-FEED, INDEXABLE CERAMIC END MILL - CHIPSURFER (6 MM INSERT)

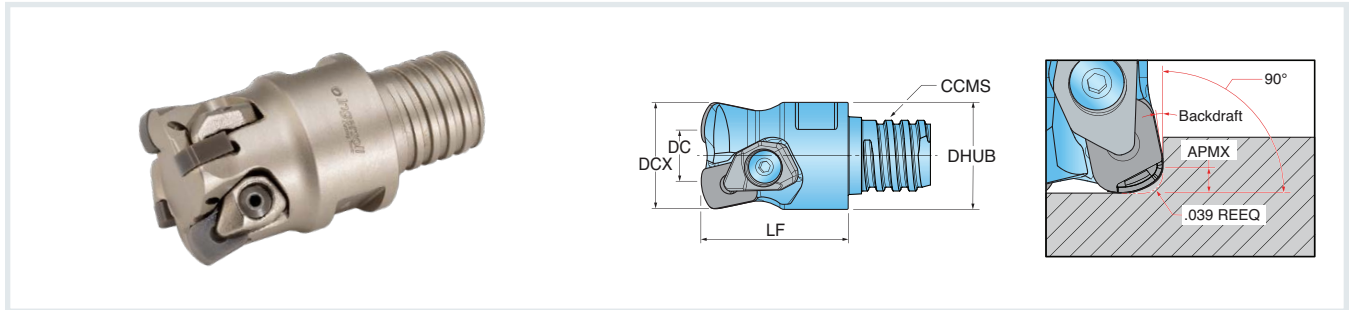

Part Number	DCX Cutting Dia Max.	DC Cutting Dia.	APMX Depth of Cut Max.	LF Functional Length	ZEFF Eff. Teeth	DHUB Hub Dia.	CCMS Connection Code Machine Side	RMPX Ramp Angle Max.	CSP Coolant (air only)
INCH									
1ZG3D-06008TRR01	0.625	0.333	0.039	0.83	2	0.60	Chip Surfer T10	0.5°	No
1ZG3D-07010TSR01	0.750	0.455	0.039	1.00	3	0.72	Chip Surfer T12	0.5°	Yes
1ZG3D-10013TUR01	1.000	0.700	0.039	1.25	4	0.95	Chip Surfer T15	0.4°	Yes

6 mm • Inserts NEW

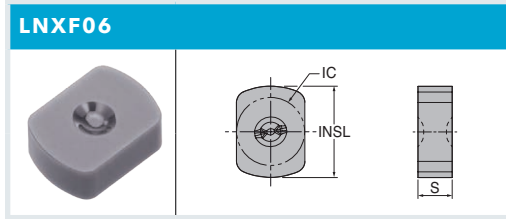



Suggested Operating Parameters

AP Depth of Cut	FZ Feed Per Tooth (in)
.015 - .031	.004 - .012

Part Number	Application	REEQ Program Radius Equivalent	INSL Insert Length	W Insert Width	S Thickness Overall	NOI Number of Indexes	IH Insert Hand	Grade
								IN76N
LNXF0603R01	Multi-Purpose	.079	.315	.236	.118	4	Right	•

Hardware

	 Clamp	 Driver
1ZG3D-06010R7R01	CCL-2S-ASSY	L-W1.5
1ZG3D-07010S7R01	CCL-2S-ASSY	L-W1.5
1ZG3D-10016S1R01	CCL-2S-ASSY	L-W1.5
1ZG3D-12016S9R01	CCL-2S-ASSY	L-W1.5
1ZG3D-06010X5R01	CCL-2S-ASSY	L-W1.5
1ZG3D-07012X6R01	CCL-2S-ASSY	L-W1.5
1ZG3D-10014X7R01	CCL-2S-ASSY	L-W1.5
1ZG3D-12016X8R01	CCL-2S-ASSY	L-W1.5
1ZG3D-06010TRR01	CCL-2S-ASSY	L-W1.5
1ZG3D-07010TSR01	CCL-2S-ASSY	L-W1.5
1ZG3D-10013TUR01	CCL-2S-ASSY	L-W1.5

9 mm • Series 1ZG3F

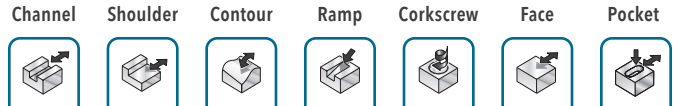

HI-FEED, INDEXABLE CERAMIC END MILL - CYLINDRICAL (9 MM INSERT)

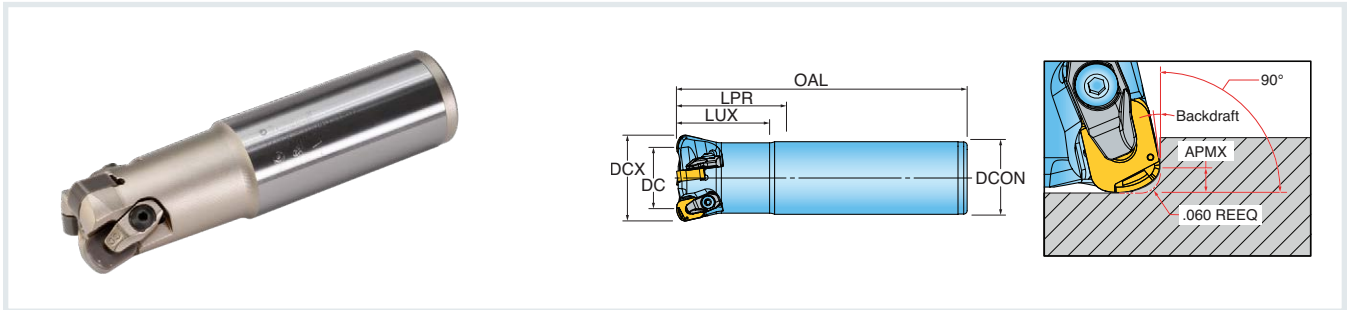

Part Number	DCX Cutting Dia Max.	DC Cutting Dia.	APMX Depth of Cut Max.	OAL Overall Length	ZEFF Eff. Teeth	DCON Shank Dia.	LUX Usable Length Max.	LPR Protruding Length	CSP Coolant	RMPX Ramp Angle Max.
INCH										
1ZG3F-10040S1R01	1.000	0.600	.060 (1.5 mm)	4.000	2	1.000	1.600	1.76	Air	.7°
1ZG3F-10040S1R02	1.000	0.600	.060 (1.5 mm)	4.000	3	1.000	1.600	1.76	Air	.7°
1ZG3F-12050S1R01	1.250	0.838	.060 (1.5 mm)	5.00	3	1.250	1.600	2.72	Air	.6°
1ZG3F-15050S1R01	1.500	1.084	.060 (1.5 mm)	5.000	4	1.250	1.600	2.72	Air	.65°

9 mm • Series TG1Q, TG2Q

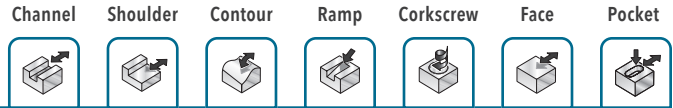

HI-FEED, INDEXABLE CERAMIC FACE MILL (9 MM INSERT)

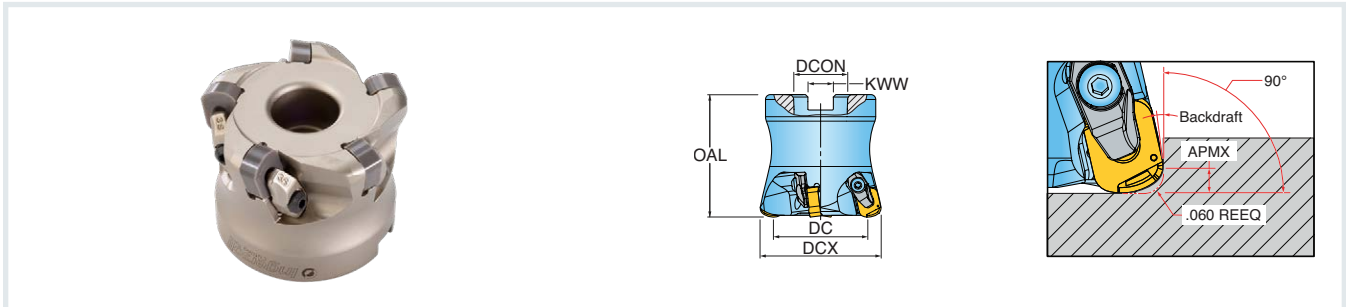

Part Number	DCX Cutting Dia Max.	DC Cutting Dia.	APMX Depth of Cut Max.	OAL Overall Length	ZEFF Eff. Teeth	DCON Shank Dia.	KWW Keyway	CSP Coolant	RMPX Ramp Angle Max.
INCH									
TG1Q-20R01	2.000	1.583	.060 (1.5 mm)	1.570	5	0.750	0.312	Air	.55°
TG2Q-20R01	2.000	1.583	.060 (1.5 mm)	1.570	4	0.750	0.312	Air	.55°

12 mm • Series DG1H, DG2H

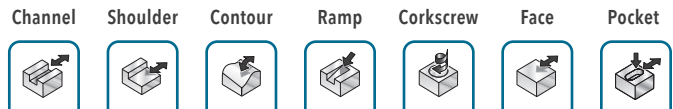

HI-FEED, INDEXABLE CERAMIC FACE MILL (12 MM INSERT)

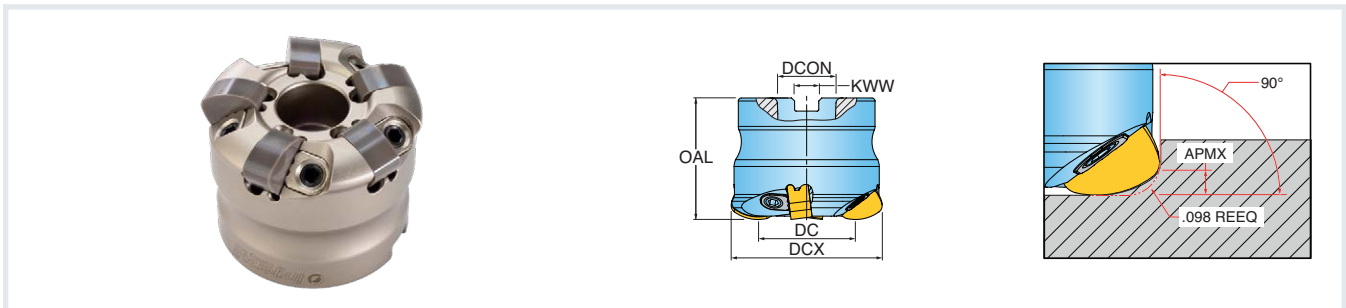

Part Number	DCX Cutting Dia Max.	DC Cutting Dia.	APMX Depth of Cut Max.	OAL Overall Length	ZEFF Eff. Teeth	DCON Shank Dia.	KWW Keyway	CSP Coolant	RMPX Ramp Angle Max.
INCH									
DG1H-20R01	2.000	1.320	.098 (2.5 mm)	1.575	5	0.750	0.312	Air	0.6°
DG2H-20R01	2.000	1.320	.098 (2.5 mm)	1.575	4	0.750	0.312	Air	0.6°
DG1H-25R01	2.500	1.820	.098 (2.5 mm)	1.575	7	0.750	0.312	Air	0.5°
DG2H-25R01	2.500	1.820	.098 (2.5 mm)	1.575	6	0.750	0.312	Air	0.5°
DG1H-30R01	3.000	2.315	.098 (2.5 mm)	1.575	8	1.000	0.375	Air	0.45°
DG2H-30R01	3.000	2.135	.098 (2.5 mm)	1.575	7	1.000	0.375	Air	0.45°

9 mm • Inserts

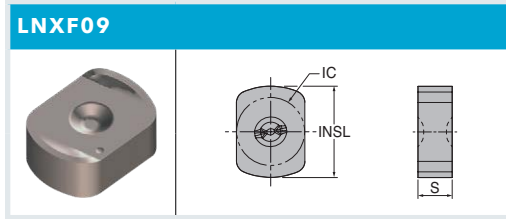

Suggested Operating Parameters

AP Depth of Cut	FZ Feed Per Tooth (in)
.020 ----> .040	.006 ----> .014

Part Number	Application	REEQ Program Radius Equivalent	INSL Insert Length	W Insert Width	S Thickness Overall	NOI Number of Indexes	IH Insert Hand	Grade
								IN76N
LNXF0905R01	Multi-Purpose	.134	.472	.354	.197	4	Right	•

12 mm • Inserts

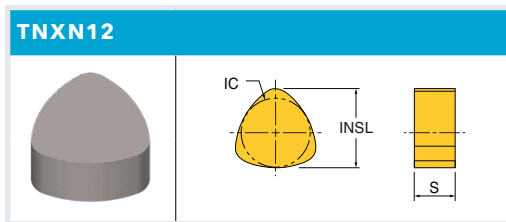





Suggested Operating Parameters

AP Depth of Cut	FZ Feed Per Tooth (in)
.040 ----> .080	.006 ----> .014

Part Number	Application	REEQ Program Radius Equivalent	INSL Insert Length	IC Inscribed Circle Dia.	S Thickness Overall	NOI Number of Indexes	IH Insert Hand	Grade
								IN76N
TNXN1207R01	Multi-Purpose	.177	.535	.472	.276	6	Right	•

Hardware

	 Clamp	 Wrench	 Wedge	 Wedge Screw	 Driver
1ZG3F-10040S1R01	CCL-3S-ASSY	L-W2	-	-	-
1ZG3F-10040S1R02	CCL-3S-ASSY	L-W2	-	-	-
1ZG3F-12050S1R01	CCL-3S-ASSY	L-W2	-	-	-
1ZG3F-15050S1R01	CCL-3S-ASSY	L-W2	-	-	-
TG1Q-20R01	CCL-3S-ASSY	L-W2	-	-	-
TG2Q-20R01	CCL-3S-ASSY	L-W2	-	-	-
DG1H-20R01	-	-	WFZ6-C	WS6	DS-H03T
DG2H-20R01	-	-	WFZ6-C	WS6	DS-H03T
DG1H-25R01	-	-	WFZ6-C	WS6	DS-H03T
DG2H-25R01	-	-	WFZ6-C	WS6	DS-H03T
DG1H-30R01	-	-	WFZ6-C	WS6	DS-H03T
DG2H-30R01	-	-	WFZ6-C	WS6	DS-H03T

6 mm • Recommended Ramping Angle

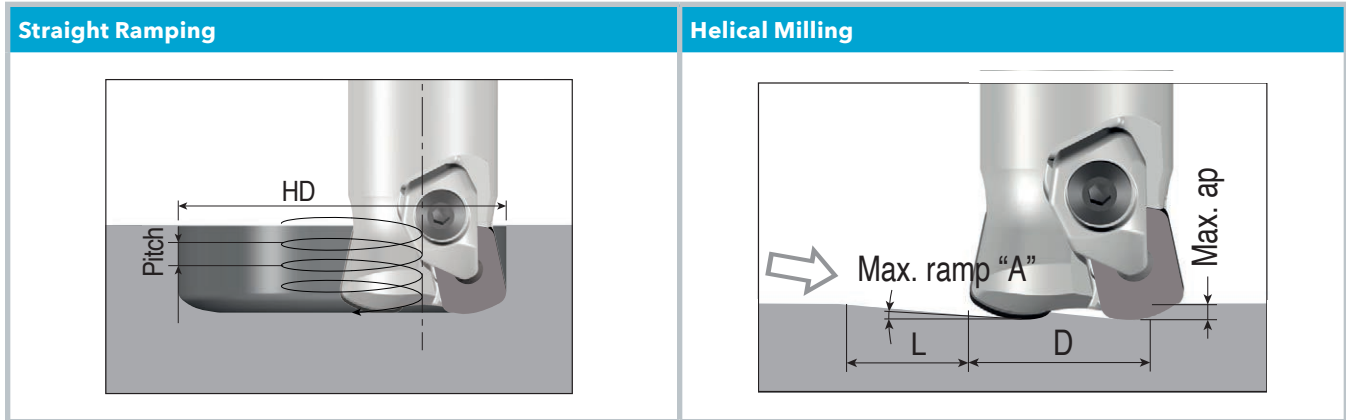

Part Number	DCX Cutting Dia Max.	Straight Ramp Down			Helical Ramp Down		
		RMPX Ramp Angle Max.	APMX Depth of Cut Max.	L Ramp Length Min.	HD Hole Dia. Min.	HD Hole Dia. Max.	Max Pitch Per Revolution
1ZG3D	0.625	0.4	.039 (1 mm)	5.570	0.996	-	0.008
					-	1.250	0.013
	0.750	0.55		4.133	1.244	-	0.014
					-	1.500	0.022
	1.000	0.4		5.570	1.739	-	0.016
					-	2.000	0.021
	1.250	0.35		6.457	2.237	-	0.018
					-	2.500	0.023

9 mm • Recommended Ramping Angle

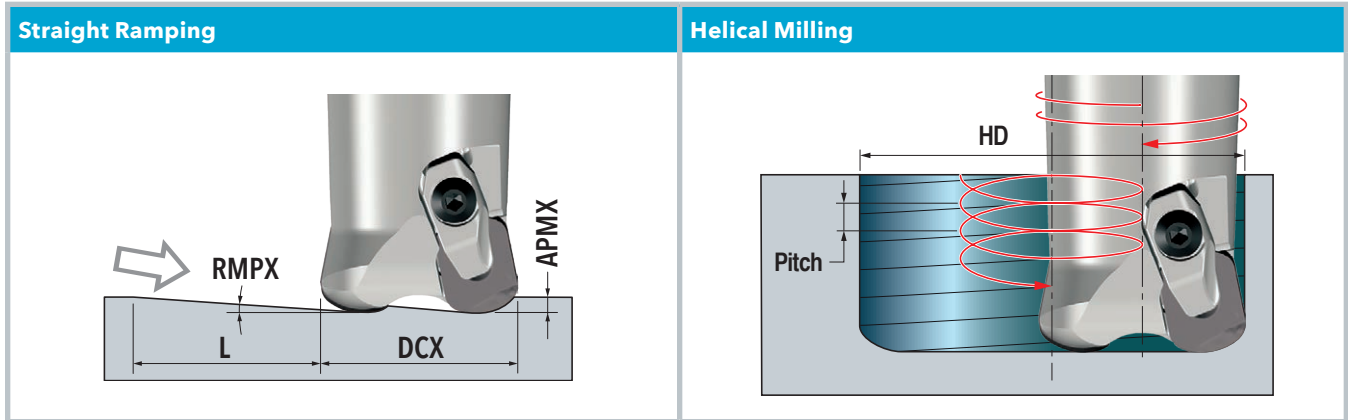

Part Number	DCX Cutting Dia Max.	Straight Ramp Down			Helical Ramp Down		
		RMPX Ramp Angle Max.	APMX Depth of Cut Max.	L Ramp Length Min.	HD Hole Dia. Min.	HD Hole Dia. Max.	Max Pitch Per Revolution
1ZG3F	1.000	0.7	.060 (1.5 mm)	4.850	1.638	-	0.020
					-	2.000	0.035
	1.250	0.6		5.630	2.126	-	0.025
					-	2.500	0.035
	1.500	0.65		5.200	2.622	-	0.035
					-	3.000	0.050
TG1Q, TG2Q	2.000	0.55	6.150	3.622	-	0.040	
				-	4.000	0.050	

12 mm • Recommended Ramping Angle

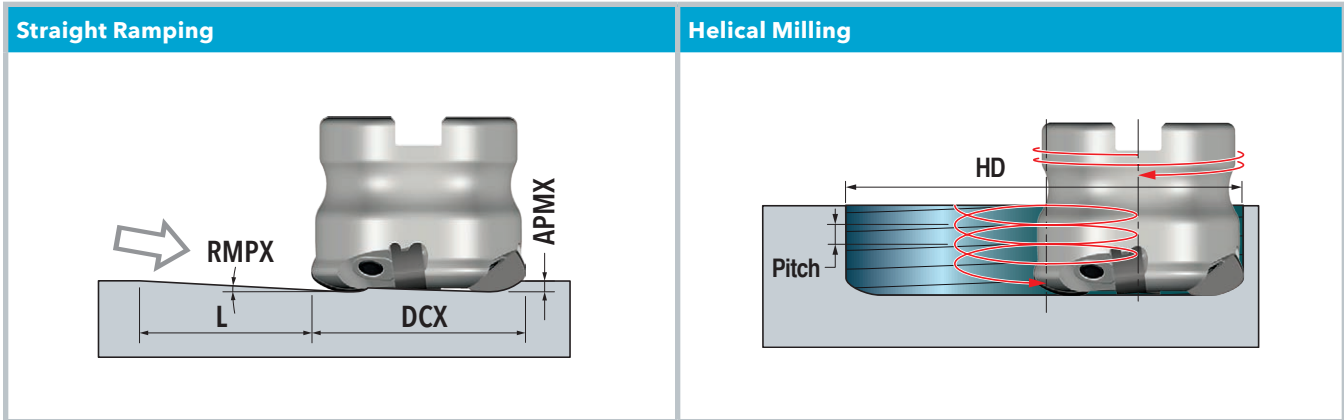

Part Number	DCX Cutting Dia Max.	Straight Ramp Down			Helical Ramp Down		
		RMPX Ramp Angle Max.	APMX Depth of Cut Max.	L Ramp Length Min.	HD Hole Dia. Min.	HD Hole Dia. Max.	Max Pitch Per Revolution
DG1H, DG2H	2.000	0.6	.098 (2.5 mm)	9.410	3.362	-	0.040
					-	4.000	0.060
	2.500	0.5		11.300	4.358	-	0.050
					-	5.000	0.060
	3.000	0.45		12.520	5.315	-	0.050
					-	6.000	0.070

6 mm • Programming Technical Data

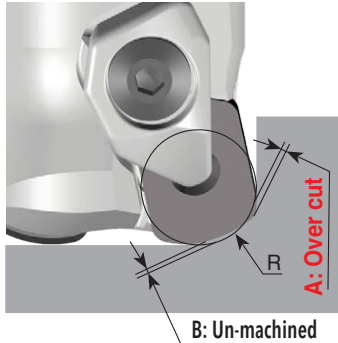

Part Number	REEQ Program Radius	A Over Cut	B Un-Machined
LNXF0603R01	.060 (1.5 mm)	0.00	.024
	.079 (2 mm)*	0.00	.017
	.098 (2.5 mm)	.004	.011

* Recommended Program Radius

9 mm • Programming Technical Data

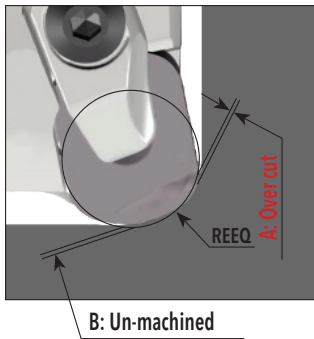

Part Number	REEQ Program Radius	A Over Cut	B Un-Machined
LNXF0905R01	.118 (3.0 mm)	0	0.024
	.134 (3.4 mm)*	0	0.018
	.138 (3.5 mm)	0.0004	0.017
	.157 (4.0 mm)	0.005	0.010

* Recommended Program Radius

12 mm • Programming Technical Data

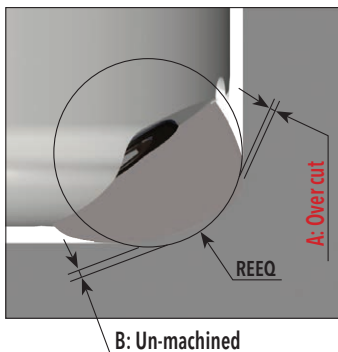

Part Number	REEQ Program Radius	A Over Cut	B Un-Machined
TNXN1207N01	.157 (4.0 mm)	0	0.046
	.177 (4.5 mm)*	0	0.039
	.197 (5.05 mm)	0.001	0.033

* Recommended Program Radius

Operating Guidelines • 6 mm

Materials				Vc Cutting Speed SFM	Ap Recommended (DOC)	Fz Feed per Tooth (in)	Coolant
ISO	Material Group #VDI 3323	Type	Examples				
S	31 thru 35	High-Temp Alloys	Inconel, Hastelloy, Nimonic, Monel	2000 - 3300	.015 - .030	.004 - .012	No

Note: Feed and speed recommendations are starting operating parameters. They are only guidelines from which further optimization should take place. Operating parameters are influenced by many machining variables. These variables may cause for reductions in feeds and speed or dramatic increases. Additionally, DOC and WOC may need to be revised to optimize the tools performance.

Operating Guidelines • 9 mm

Materials				Vc Cutting Speed SFM	Ap Recommended (DOC)	Fz Feed per Tooth (in)	Coolant
ISO	Material Group #VDI 3323	Type	Examples				
S	31 thru 35	High-Temp Alloys	Inconel, Hastelloy, Nimonic, Monel	2000 - 3300	.020 - .040	.006 - .014	No

Note: Feed and speed recommendations are starting operating parameters. They are only guidelines from which further optimization should take place. Operating parameters are influenced by many machining variables. These variables may cause for reductions in feeds and speed or dramatic increases. Additionally, DOC and WOC may need to be revised to optimize the tools performance.

Operating Guidelines • 12 mm

Materials				Vc Cutting Speed SFM	Ap Recommended (DOC)	Fz Feed per Tooth (in)	Coolant
ISO	Material Group #VDI 3323	Type	Examples				
S	31 thru 35	High-Temp Alloys	Inconel, Hastelloy, Nimonic, Monel	2000 - 3300	.020 - .078	.006 - .014	No

Note: Feed and speed recommendations are starting operating parameters. They are only guidelines from which further optimization should take place. Operating parameters are influenced by many machining variables. These variables may cause for reductions in feeds and speed or dramatic increases. Additionally, DOC and WOC may need to be revised to optimize the tools performance.