



PARTING & GROOVING

Minimum Bore Diameter

6 mm (.236")

8 mm (.315")

Insert Widths

0.5~2.0 mm (.020~.079")

Max. Cutting Depth

0.5~1.5 mm (.020~.059")

Grades

TT4430 - PVD-AlTiCrN coated

TT8020 - PVD-TiCN coated

Shank Sizes

Carbide Shanks -

6 mm, 12 mm, and .500"

Steel Shanks -

12 mm and .500"

Applications

Small parts machining

Steel, stainless steel, titanium

WIN | GROOVE™

Miniature Size Inserts and Holders for Shallow Internal Grooving

- » Suitable for small diameter internal grooving and turning with minimum bore diameter down to .236" (6mm)
- » Unique & stable seating, capable of internal grooving up to a flat bottom surface
- » Steel and carbide shanks with thru-coolant

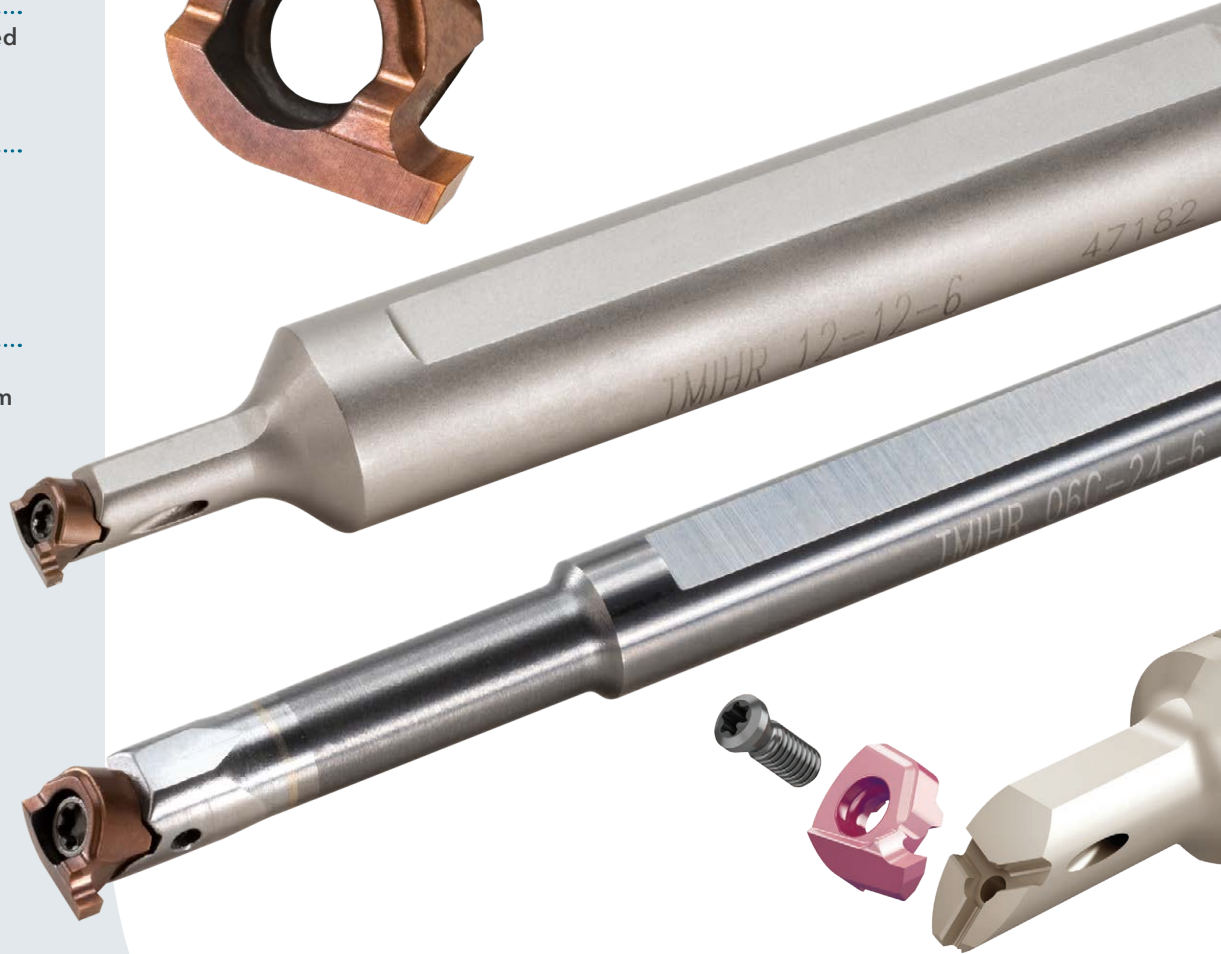

See it in
action! »



WINSPEED™
ADVANCED MACHINING

ingersoll-imc.com



WIN-I-GROOVE for the small hole internal grooving line

Ingersoll has responded to the growing demand in the miniature market for miniature inserts and dedicated holders with grooving capability in the 6-8 mm smaller diameter range.

Excellent machining performance is the result of the stronger clamping stemming from the inclined, wide contact surface design of the TMIR/L inserts and TMIHR/L holders. Additionally, the inclined clamping structure offers one further advantage, sufficient space for smooth chip evacuation.

Along with steel holders capable of 2xD depths machining, Ingersoll also offers carbide brazed holders capable of deep internal grooving up to 4xD. Tool holders include internal coolant for improved tool life and facilitates optimal chip evacuation.

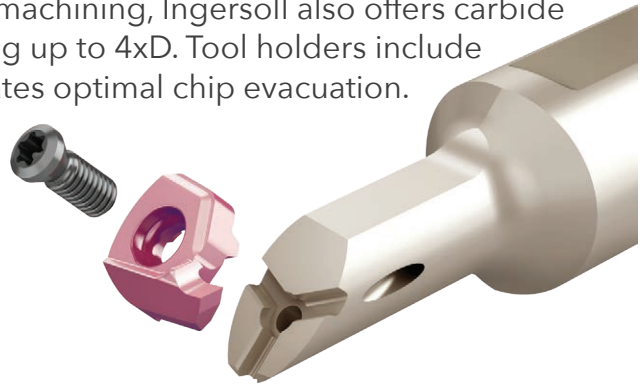

Features

- Improved economy compared to solid carbide tools with no setup needed
- Capable of small bore internal grooving up to a flat bottom surface

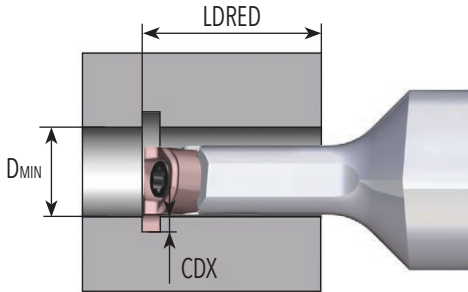

Insert	DMIN	CDX	LDRED
TMIR/L 6	0.236	.039	.94
TMIR/L 8	0.315	.059	1.26

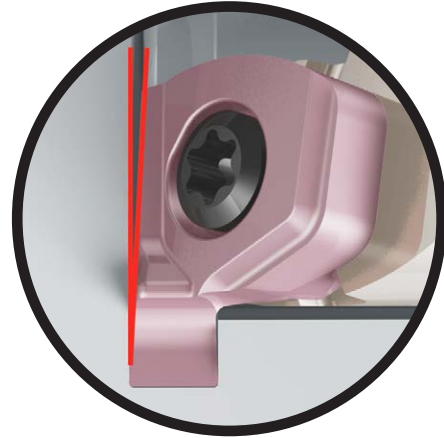

Grooving against flat bottom surface

- Unique inclined clamping system
 - Insert's wider contact area design enables excellent machining performance

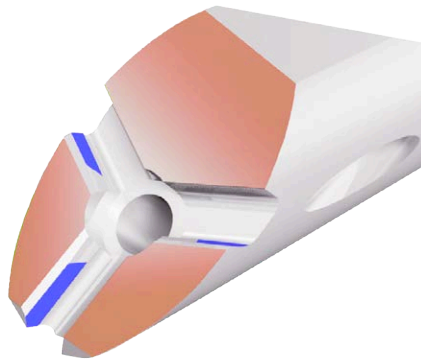
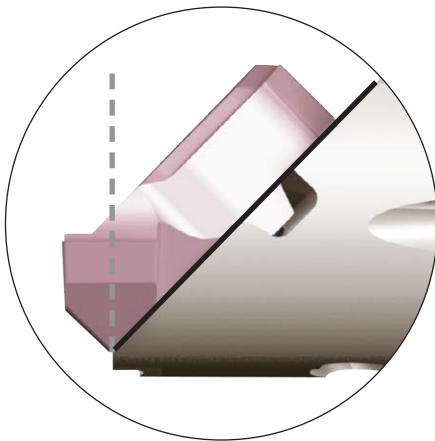

- : 3-point contact
-Insert movement during operation eliminated
- : Wider contact face
-Stable machining in both grooving and turning

- Tool's efficient design allows for excellent chip evacuation

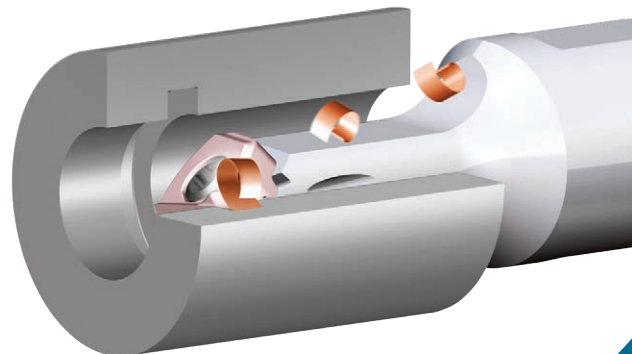
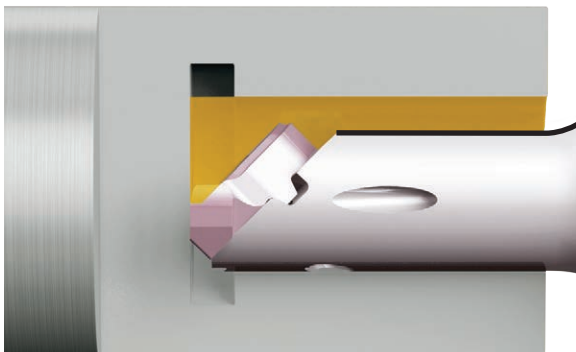

Features (cont.)

- Carbide brazed holders available for deep hole grooving
 - Steel holders



- Carbide brazed holders



- Increased tool life due to the pinpoint coolant flow to the cutting edge

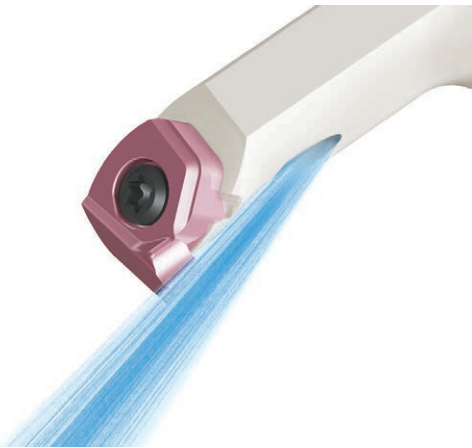

- Available in two grades: TT4430 and TT8020

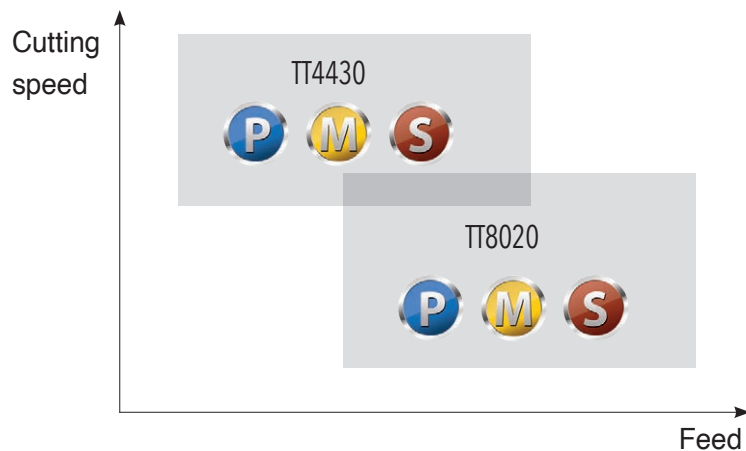

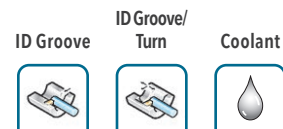

Series TMIHR/L

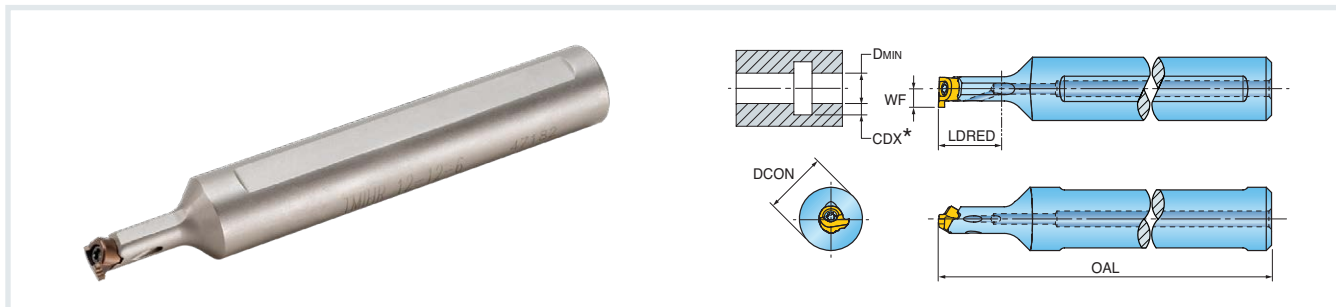

INTERNAL BORING BARS FOR SHALLOW GROOVING IN SMALL DIAMETERS



Part Number	DCON Shank Diameter	OAL Overall Length	LDRED Reduced Body Dia. Length	WF Functional Width	DMIN Minimum Bore Diameter	Insert
INCH						
TMIHR/L 12.7-12-6	.500	3.0	.50	.138	.236	TMIR/L 6...
TMIHR/L 12.7-16-8	.500	3.0	.63	.185	.315	TMIR/L 8...
METRIC						
TMIHR/L 12-12-6	12 mm	80 mm	12 mm	3.5 mm	6.0 mm	TMIR/L 6...
TMIHR/L 12-16-8	12 mm	80 mm	16 mm	4.7 mm	8.0 mm	TMIR/L 8...

* CDX: Refer to insert dimension

Hardware

Part Number	 Screw	 Torx Driver
TMIHR/L ...-6	TS 18049/HG-P	DS-TP06F
TMIHR/L ...-8	TS 20055I	DS-T06F

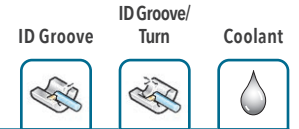

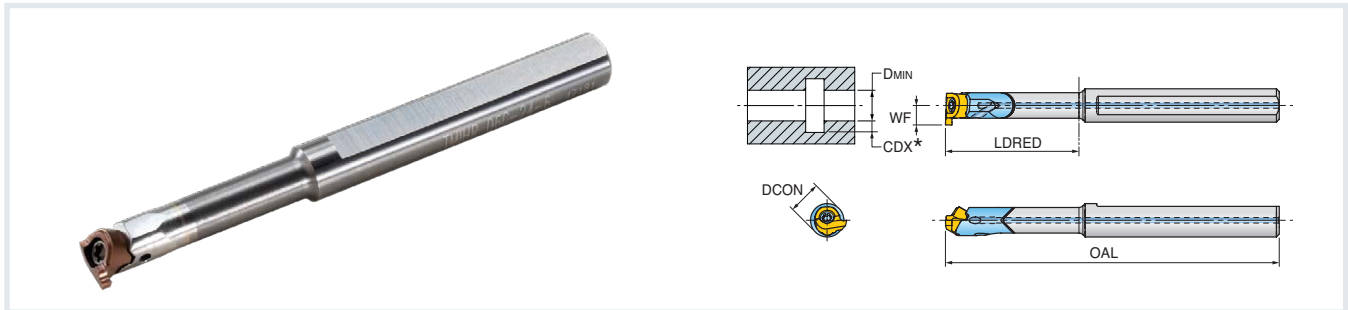

Series TMIHR/L...C

INTERNAL CARBIDE BORING BARS FOR SHALLOW GROOVING IN SMALL DIAMETERS



Part Number	DCON Shank Diameter	OAL Overall Length	LDRED Reduced Body Dia. Length	WF Functional Width	DMIN Minimum Bore Diameter	Insert
INCH						
TMIHR/L 12.7C-24-8	.500	3.6	.94	.185	.315	TMIR/L 8...
TMIHR/L 12.7C-32-8	.500	4.0	1.26	.185	.315	TMIR/L 8...
METRIC						
TMIHR/L 06C-18-6	6 mm	54 mm	18 mm	3.5 mm	6.0 mm	TMIR/L 6...
TMIHR/L 06C-24-6	6 mm	60 mm	24 mm	3.5 mm	6.0 mm	TMIR/L 6...
TMIHR/L 12C-24-8	12 mm	92 mm	24 mm	4.7 mm	8.0 mm	TMIR/L 8...
TMIHR/L 12C-32-8	12 mm	100 mm	32 mm	4.7 mm	8.0 mm	TMIR/L 8...

* CDX: Refer to insert dimension

Part Number	 Screw	 Torx Driver
TMIHR/L ...-6	TS 18049/HG-P	DS-TP06F
TMIHR/L ...-8	TS 20055I	DS-T06F

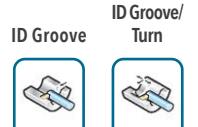

Series TMIR/L

PRECISE INSERTS FOR INTERNAL SHALLOW GROOVING IN SMALL DIAMETERS

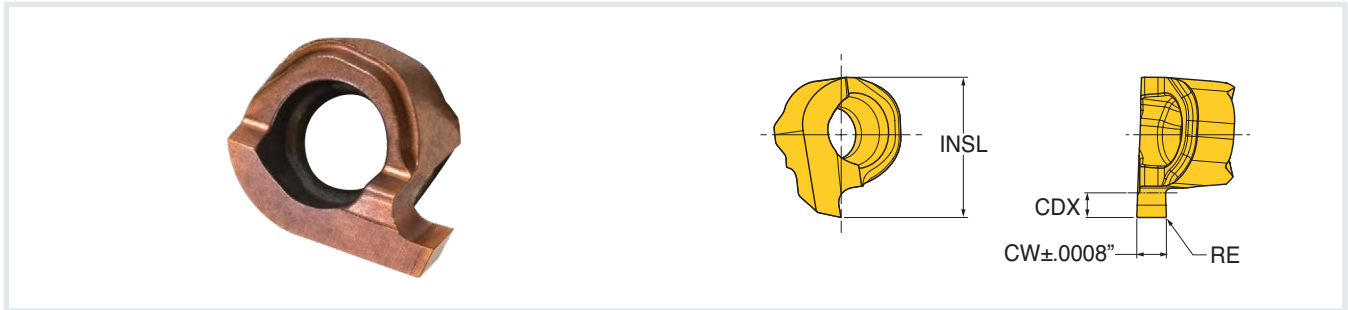

Part Number	Feed (ipr)	CW Cutting Width	RE Corner Radius	CDX Cutting Depth Max.	INSL Insert Length	Grade	
						TT4430	TT8020
INCH							
TMIR/L 6-0.50-0.00	.0004-.0012	.020	0	.020	.224	•	•
TMIR/L 6-1.00-0.00	.0004-.0012	.039	0	.039	.224	•	•
TMIR/L 6-1.20-0.05	.0004-.0012	.047	.002	.039	.224	•	•
TMIR/L 8-0.50-0.00	.0004-.0012	.020	0	.028	.291	•	•
TMIR/L 8-1.00-0.00	.0004-.0012	.039	0	.059	.291	•	•
TMIR/L 8-1.50-0.05	.0004-.0012	.059	.002	.059	.291	•	•
TMIR/L 8-2.00-0.10	.0004-.0012	.079	.004	.059	.291	•	•

Right hand insert fits right hand tool

• = Standard Items