

Operating Guidelines • HEM/Trochoidal Milling

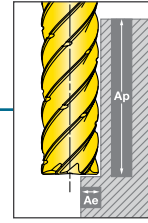

Materials				Vc Cutting Speed SFM	*fz = IPT for Ae = .05xD~.15xD • Ap = 2xD								
ISO	Material Group #VDI 3323	Type	Trade Name Examples		DC Cutting Diameter (inch)								
					.125	.188	.250	.313	.375	.500	.625	.750	1.00
M	12-14	Stainless steel (austenitic & ferritic)	416, 303, 430F	590-787	.0009- .0017	.0011- .0021	.0014- .0027	.0017- .0035	.0023- .0047	.0027- .0059	.0039- .0071	.0047- .0098	.0057- .0115
		Stainless steel (austenitic & martensitic)	420, 304, 316, 440C	415-649									
		Stainless steel (PH)	15-5 PH, 17-4 PH	375-531	.0007- .0015	.0009- .0019	.0012- .0025	.0015- .0033	.0023- .0044	.0027- .0055	.0039- .0065	.0047- .0091	.0057- .0104
		Stainless steel (duplex)	Duplex 2205, 329	197-374									

- As Ap increases to maximum 4xD, use fz from lower end of chart.
- When Ae < .10xD, use speed from the higher end of chart.

Note: Feed and speed recommendations are starting operating parameters. They are only guidelines from which further optimization should take place. Operating parameters are influenced by many machining variables. These variables may necessitate adjustments in speed or feed. Additionally, DOC and WOC may need to be revised to optimize the tools performance.

*fz = chip thinning calculations are included in the chip load above, especially when Ae ≤ .15xD.

- High pressure coolant is highly recommended, as it will provide optimal chip evacuation and performance.
- A power milling chuck, or coolant thru (CX series) holder (for tools with Weldon flats) is highly recommended, starting at .500" DC or larger. Using a weak holder impacts performance.

Chip Thinning

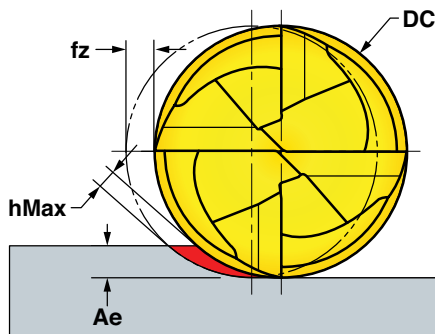

- Due to the lower radial engagement, *chip thinning* is accentuated, and a much higher feed-per-tooth (fz) can be applied in order to arrive at the true chip thickness (hMax).
- When Ae ≤ .25xD, recommend use of **Chip Thinning Calculator** to ensure hMax is within fz range.
- If needed, Chip Thinning Calculator can be found on our website Machining App.

